

INFORMAZIONI GENERALI

Il presente catalogo serve per richiedere con esattezza le parti di ricambio.

Nelle ordinazioni indicare:

- 1) il numero di codice dei particolari seguito dalla descrizione;
- 2) il colore per i pezzi verniciati o comunque colorati;
- 3) il numero di matricola del motociclo, stampigliato sul canotto di sterzo.

Le indicazioni destra e sinistra si riferiscono ai lati del veicolo rispetto al senso di marcia.

GENERAL INFORMATION

The present spare parts list enables one to order exactly the right spare parts.

When ordering specify:

- 1) the part's code number followed by its description;
 - 2) indicate colour for painted or coloured parts;
 - 3) the motorcycle's serial number, stamped on the steering head.
- References to right and left apply to the vehicle in terms of its direction of movement.

INFORMATIONS GENERALES

Ce catalogue permet de commander correctement les pièces de rechange.

Les commandes doivent être passées en indiquant:

- 1) le numéro de code des pièces détachées suivi de leur description;
- 2) le couleur des pièces peintes ou colorés;
- 3) le matricule de la moto, estampillé sur la tige du guidon.

Droite et gauche sont les côtés du véhicule par rapport au sens de la marche.

ALLGEMEINE HINWEISE

Dieser Ersatzteilkatalog dient zur genauen Angabe der Teile bei Ersatzteilbestellungen.

Bei Ersatzbestellung ist folgendes anzugeben:

- 1) Die Bestellnummer der Ersatzteile mit der entsprechenden Beschreibung;
- 2) Farbe für lackierte und farbige Teile angeben;
- 3) Die Seriennummer des Motorrads, die am Lenkrohr eingepreßt ist.

Die Angaben rechts und links beziehen sich auf das Fahrzeug in Fahrrichtung.

INFORMACIONES GENERALES

El presente catálogo sirve para pedir con exactitud las partes de recambio.

En los pedidos se debe indicar:

- 1) el número de código de la parte y a continuación la descripción;
- 2) el color para las piezas barnizadas o coloreadas;
- 3) el número de matricula de la motocicleta, estampado en el tubo de dirección.

Las indicaciones derecha e izquierda se refieren a los lados del vehículo respecto del sentido de marcha.

Note - List - Notes - Note - Notas:

- A** : In alternativa - In alternative - En alternative - Wahlweise
En alternativa
- C** : Fornire in coppia - Delivered by pairs - Livrées par paire
Paarweise geliefert - Equipar por parejas
- D** : In dotazione - To issue - En nécessaire - Ausrüstungsteile
En dotación
- E** : Fornire fino ad esaurimento - To fell out - A' finir - Erschöpfung
A agotamiento
- F** : Fornire assieme - Supply unitedly - Fournir ensemble
Wird zusammen geliefert - Equipar juntos
- H** : Contenuto in busta guarnizioni - It's contained in the gasket set
Contenu entre l'enveloppe du joints - In den
Reparaturendichtungssatz
Se encuentra en la bolsa de guarniciones
- N** : Non fornito - Not supplied - Ne pas fournit - Nicht Versorgt
No se provee
- R** : A richiesta - Upon request - Sur demande - Auf Anfrage
Bajo pedido
- S** : Di serie - Supplied - De série - Standard - De serie
- SS** : Modello SMS- SMS model - Modèle SMS- Modell SMS
Modélo SMS
- TT** : Modello TEE- TEE model - Modèle TEE- Modell TEE
Modélo TEE
- Z** : n° denti, number of teeth, numéro dents, Zähne nummer,
número diente
- (&)**,
(@) : Montati assieme - Assembled together - Monté ensemble
Wird zusammen montiert - montados junto

- A** : Austria, Austria, Autriche, Österreich, Austria
- AUS** : Australia, Australia, Australie, Australien, Australia
- B** : Belgio, Belgium, Belgique, Belgien, Bélgica
- BR** : Brasile, Brazil, Brésil, Brasilien, Brasil
- CDN** : Canada, Canada, Canada, Kanada, Canadá
- CH** : Svizzera, Switzerland, Suisse, Schweizer, Suiza
- D** : Germania, Germany, Allemagne, Deutschland, Alemania
- E** : Spagna, Spain, Espagne, Spanien, España
- F** : Francia, France, France, Frankreich, Francia
- GB** : Gran Bretagna, Great Britain, Grand Bretagne
Groos Britan, Gran Bretaña
- I** : Italia, Italy, Italie, Italien, Italia
- J** : Giappone, Japan, Japon, Japan, Japón
- SF** : Finlandia, Finland, Finlande, Finnland, Finlandia
- USA** : Stati Uniti d'America, United States of America
Etats Unis d'Amerique,
Vereinigte Staaten von Amerika, Estados Unidos

Validità - Validity - Validité - Gültig - Validez:

- F.m.** : Fino alla matricola - Until V.I.N. - Jusqu'au matricule
Bis zu Matrikel - Hasta la matrícula
- D.m.** : Dalla matricola - From V.I.N. - Du matricule - Vom Matrikel
Desde la matrícula

Il n° di matricola iniziale del modello **TE 610 E/ 2004** è **ZCGH700AA4V005000**
Il n° di matricola iniziale del modello **SM 610 S/ 2004** è **ZCGH701AA4V005000**

The initial serial number for the **TE 610 E/ 2004** model is **ZCGH700AA4V005000**
The initial serial number for the **SM 610 S/ 2004** models is **ZCGH701AA4V005000**

Le matricule initial du modèle **TE 610 E/ 2004** est **ZCGH700AA4V005000**
Le matricule initial du modèle **SM 610 S/ 2004** est **ZCGH701AA4V005000**

Die Seriennummer des Modells **TE 610 E/ 2004** beginnt mit **ZCGH700AA4V005000**
Die Seriennummer des Modells **SM 610 S/ 2004** beginnt mit **ZCGH701AA4V005000**

El n° de matrícula inicial de la motocicleta **TE 610 E/ 2004** es **ZCGH700AA4V005000**
El n° de matrícula inicial de la motocicleta **SM 610 S/ 2004** es **ZCGH701AA4V005000**

Codice colore "E" moto "giallo-nera"
Color code "E" "yellow-black" motorcycle
Code couleur "E" moto "jaune-noir"
Code Farbe "E" motorrad "Gelb-Schwarz"
Codigo de color "E" moto "amarillo-negro".

Codice colore "F" moto "nera"
Color code "F" "black" motorcycle
Code couleur "F" moto "noir"
Code Farbe "F" motorrad "Schwarz"
Codigo de color "F" moto "negro".

Dati indicativi soggetti a modifiche senza impegno di preavviso.
All data are subject to modification without prior notice.
Données indicatif sujet au modifications sans obligation de préavis.
Anderungen Vorbehalten.
Datos indicativos sujetos a modificaciones sin compromiso de preaviso.

Tavola Drawing Table Bild Tabla	Denominazione	Description	Designation	Bezeichnung	Denominacion	Pagina Page Seite Paja
1	ATTREZZI DI ASSISTENZA, MANUALI D'ISTRUZIONI E DI SERVIZIO	SERVICE TOOLS, OWNER'S AND SERVICE MANUALS	OUTILS D'ASSISTANCE, EMPLOI D'ENTRETIEN ET DE SERVICE	HILFAUSRUSTUNG, BETRIEBSANLEITUNG, WERKSTATTHANDBUCH	HERRAMIENTAS DE MANUALES DE INSTRUCCIONES Y SERVICIO	13
2	TESTA, CILINDRO	CYLINDER HEAD, CYLINDER	CULASSE, CYLINDRE	ZYLINDERKOPF, ZYLINDER	CULATA, CILINDRO	15
3	DISTRIBUZIONE	VALVE TIMING	DISTRIBUTION	VENTILSTEUERUNG	DISTRIBUCION	21
4	PISTONE, MANOVELLISMO	PISTON, CRANKSHAFT	PISTON, VILEBREQUIN	KOLBEN, KURBELWELLE	PISTON, PALANCAS	23
5	RAFFREDDAMENTO	COOLING SYSTEM	REFROIDISSEMENT	WASSERKÜHLUNG	ENFRIAMIENTO	25
6	SEMICARTER SINISTRO	L.H. HALF CRANKCASE	CARTER G.,	GEHAUSEDECKEL L.,	BANCADA IZQ.	31
7	SEMICARTER DESTRO	R.H. HALF CRANKCASE	CARTER D.	GEHAUSEDECKEL R.	BANCADA DER.	35
8	COPERCHI BASAMENTO	CRANKCASE COVERS	COUVERCLES CARTER	GEHÄUSEDECKEL	TAPA BANCADA	37
9	CAMBIO, FRIZIONE	TRANSMISSION, CLUTCH	BOITE DE VITESSE, EMBRAYAGE	WECHSELGETRIEBE, KUPPLUNG	CAMBIO, EMBRAGUE	39
10	COMANDO CAMBIO	SHIFTER	COMMANDE DE VITESSE	GANGSCHALTUNG	MANDO CAMBIO	45
11	LUBRIFICAZIONE	LUBRICATION	GRAISSAGE	SCHMIERUNG	LUBRICACIÓN	49
12	PARTE ELETTRICA	IGNITION SYSTEM	PARTIES ELECTRIQUES	ELEKTRISCHE TEILE	PARTE ELECTRICA	53
13	CARBURATORE (Dell'Orto) (TEE)	CARBURETOR (Dell'Orto) (TEE)	CARBURATEUR (Dell'Orto) (TEE)	VERGASER (Dell'Orto) (TEE)	CARBURADOR (Dell'Orto) (TEE)	57
13A	CARBURATORE (Mikuni) (SMS)	CARBURETOR (Mikuni) (SMS)	CARBURATEUR (Mikuni) (SMS)	VERGASER (Mikuni) (SMS)	CARBURADOR (Mikuni) (SMS)	63
14	FILTRO ARIA	AIR FILTER	FILTRE AIRE	LUFTFILTER	FILTRO DE AIRE	65
15	TELAIO, PEDANE	FRAME, FOOT RESTS	CADRE, REPOSE PIEDS	RAHMEN, FUSSBRETT	BASTIDOR, REPOSAPIES	71
16	SOSPENSIONE ANTERIORE	FRONT FORK ASSEMBLY	SUSPENSION AVANT	VORDETELESKOPGABEL	SUSPENSION DELANTERA	79
17	FORCELLONE	SWING ARM	FOURCHE	HINTERGABEL	HORQUILLA TRASERA	79
17A	LEVERAGGI SOSP. POST.	REAR SUSPENSION LINKAGE	LEVIER SUSPENSION ARRIERE	HEBELWERK	PALANCA SUSPENSION TRAS.	83
18	AMMORTIZZATORE POST.	REAR SHOCK ABSORBER	AMMORTISSEUR ARRIÈRE	HINTERSTOSSDAMPFER	AMORTIGUADOR TRASERO	85
19	MANUBRIO E COMANDI	HANDLEBAR AND CONTROLS	GUIDON ET COMMANDES	LENKER UND STEUERORGANE	MANILLAR Y MANDOS	87
20	FRENO IDRAULICO POSTERIORE	REAR HYDRAULIC BRAKE	FREIN HYDRAULIQUE ARRIERE	HINTERBREMSE	FRENO HIDRAULICO TRASERO	91
21	PANNELLI, PARAFANGHI, SELLA	PANEL, FENDERS, SEAT	PANNEAU, GARDE-BOUES , SIEGE	STREIFEN, KOTFLUGEL, SATTEL	PANELES, GUARDABARROS, SILLIN	93
22	SERBATOIO CARBURANTE	GAS TANK	RESERVOIR CARBURANT	KRAFTSTOFFBEHALTER	DEPOSITO GASOLINA	97
23	SCARICO	EXHAUST SYSTEM	TUYAU D'ECHAPPEMENT	AUSPUFFROHR	TUBO DE ESCAPE	99
24	FRENO IDRAULICO ANTERIORE (SMS)	FRONT HYDRAULIC BRAKE (SMS)	FREIN HYDRAULIQUE AVANT (SMS)	VORTERBREMSE (SMS)	FRENO HIDRAULICO DELANTERO (SMS)	101
24A	FRENO IDRAULICO ANTERIORE (TEE)	FRONT HYDRAULIC BRAKE (TEE)	FREIN HYDRAULIQUE AVANT (TEE)	VORTERBREMSE (TEE)	FRENO HIDRAULICO DEL (TEE).	105

Tavola Drawing Table Bild Tabla	Denominazione	Description	Designation	Bezeichnung	Denominacion	Pagina Page Seite Seite Paja
25	RUOTA ANTERIORE (SMS)	FRONT WHEEL (SMS)	ROUE AVANT (SMS)	VORTERRAD (SMS)	RUEDA DELANTERA (SMS)	109
25A	RUOTA ANTERIORE (TEE)	FRONT WHEEL (TEE)	ROUE AVANT (TEE)	VORTERRAD (TEE)	RUEDA DELANTERA (TEE)	111
26	RUOTA POSTERIORE	REAR WHELL	ROUE ARRIERE	HINTERRAD	RUEDA TRASERA	113
27	CONTACHILOMETRI, BORSA ATTREZZI	SPEEDOMETER, TOOLS BAG	COMPTE-KILOMETRES, TROUSSE A OUTILS	TACHOMETER, WERKZEUGTASCHE	CUENTA-KILOMETROS, BOLSA HERRAMIENTOS	117
28	GRUPPO CAVI, PARTI ELETTRICHE	MAIN WIRING HARNESS, ELECTRICAL PARTS	CABLES PRINCIPAL,PARTIES ELECTRIQUES	KABEL, ELEKTRISCHE	GRUPO PRINCIPAL CABLES, PARTES ELECTRICAS	119
28A	FANALI, FRECCHE, PORTATARGA	HEAD LIGHT, TAIL LIGHT, BLINKERS,PLATE HOLDER	FEUX AVANT, FEUX ARRIERE, CLIGNOTANTS,PORTE-BALAI	VORDERLICHT, HINTERLICHT, BLINKERS,SCHILDTRAEGER	FARO DELANTERO, FARO TRASERO, INTERMITENTE, PORTAMATRICULA	121
29	DECALCOMANIE cod. colore E (SMS)	TRANSFER color code E (SMS)	DECALCOMANIE code couleur E (SMS)	ABZIEHBILD Code Farbe E (SMS)	CALCOMANIA còdigo colòr E (SMS)	125
29A	DECALCOMANIE codice colore F (SMS)	TRANSFER color code F (SMS)	DECALCOMANIE code couleur F (SMS)	ABZIEHBILD Code Farbe F (SMS)	CALCOMANIA còdigo colòr F (SMS)	127
29B	DECALCOMANIE codice colore F (TEE)	TRANSFER color code F (TEE)	DECALCOMANIE code couleur F (TEE)	ABZIEHBILD Code Farbe F (TEE)	CALCOMANIA còdigo colòr F (TEE)	129
-	INDICE NUMERICO PROGRESSIVO	NUMERICAL INDEX	INDEX NUMERIQUE	NUMMERNVERZEICHNIS	ÍNDICE NUMÉRICO PROGRESÍVO	130

Tavola - Drawing - Table - Bild - Tabla

1

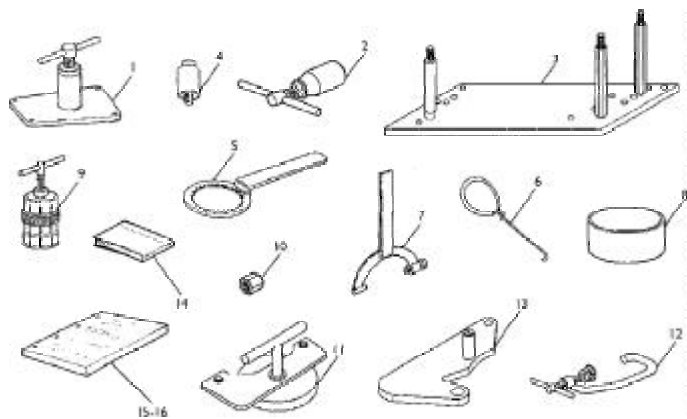

Pagina - Page - Page - Seite - Paja

12

Tavola - Drawing - Table - Bild - Tabla

2

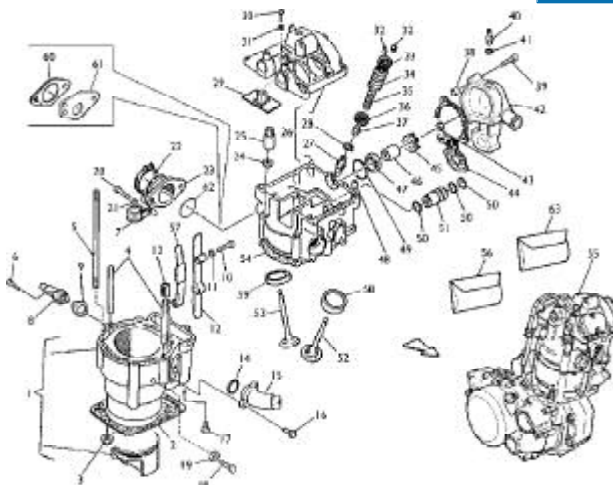

Pagina - Page - Page - Seite - Paja

14

Tavola - Drawing - Table - Bild - Tabla

3

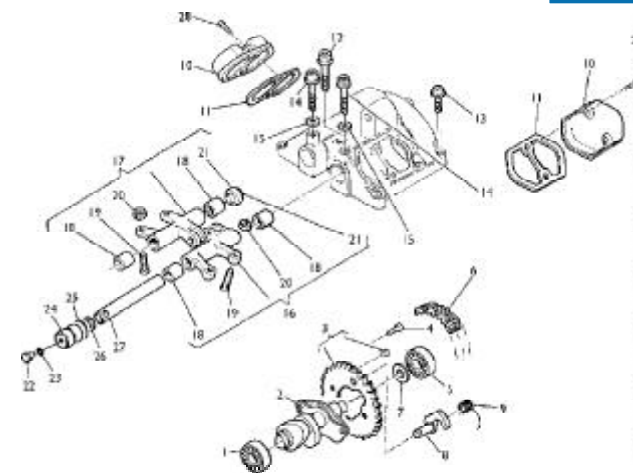

Pagina - Page - Page - Seite - Paja

20

Tavola - Drawing - Table - Bild - Tabla

4

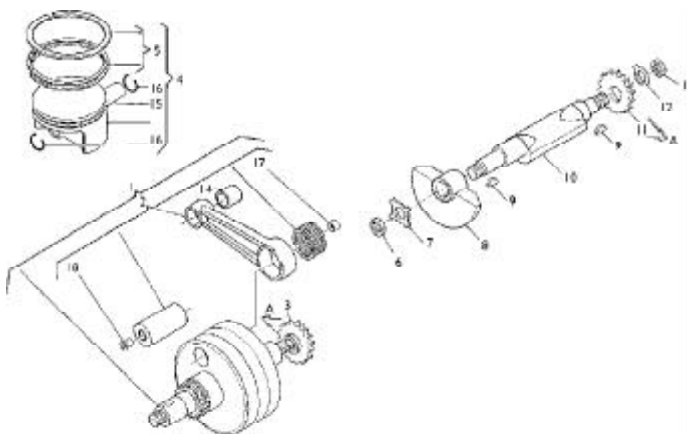

Pagina - Page - Page - Seite - Paja

22

Tavola - Drawing - Table - Bild - Tabla

5

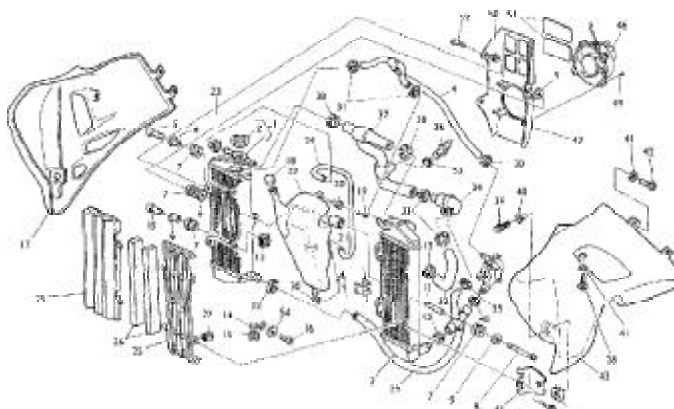

Pagina - Page - Page - Seite - Paja

24

Tavola - Drawing - Table - Bild - Tabla

6

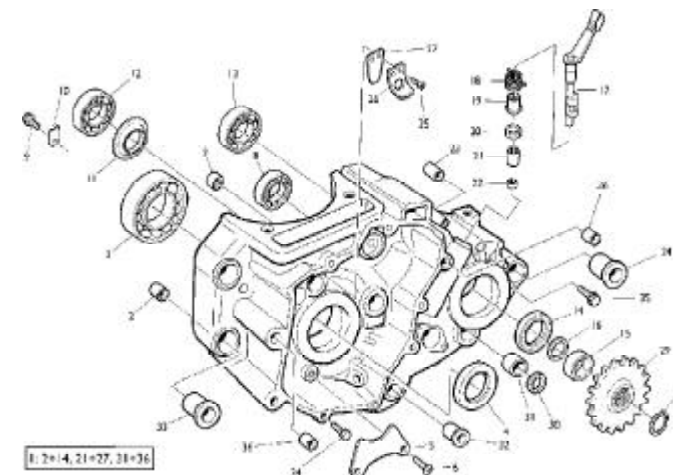

Pagina - Page - Page - Seite - Paja

30

Tavola - Drawing - Table - Bild - Tabla

7

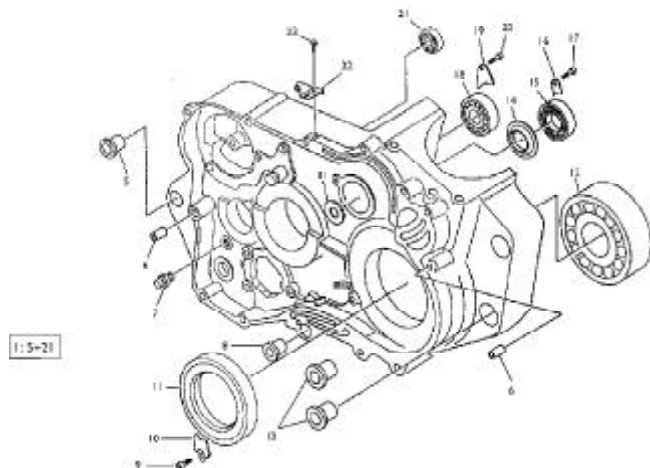

Pagina - Page - Page - Seite - Paja

34

Tavola - Drawing - Table - Bild - Tabla

8

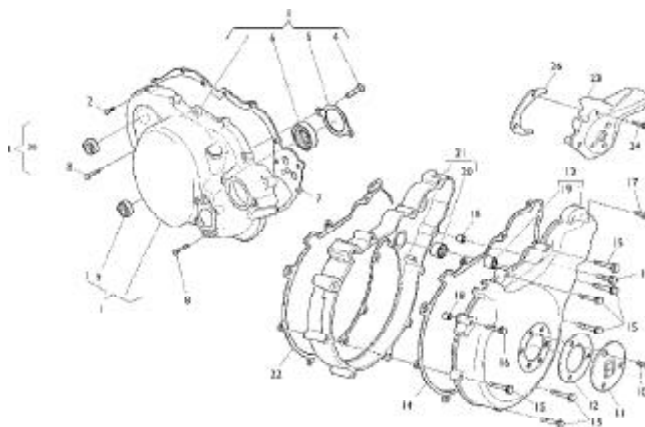

Pagina - Page - Page - Seite - Paja

36

Tavola - Drawing - Table - Bild - Tabla

9

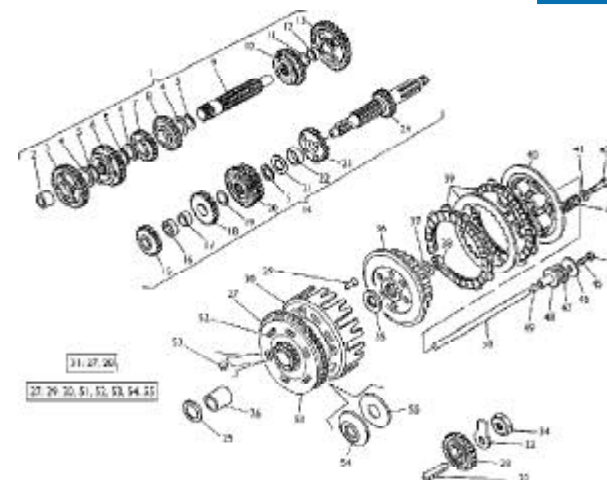

Pagina - Page - Page - Seite - Paja

38

Tavola - Drawing - Table - Bild - Tabla

10

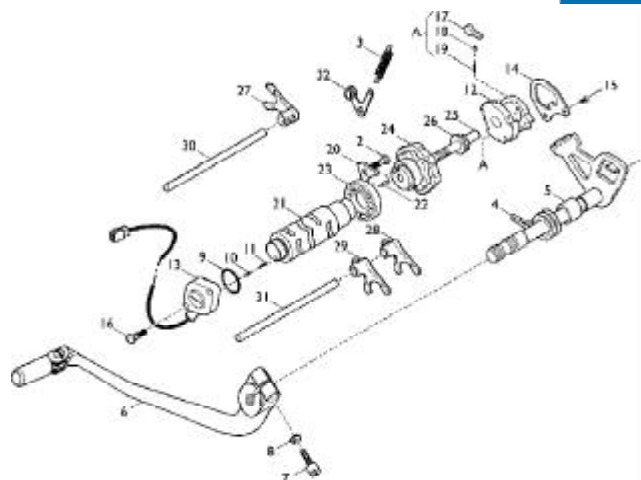

Pagina - Page - Page - Seite - Paja

44

Tavola - Drawing - Table - Bild - Tabla

11

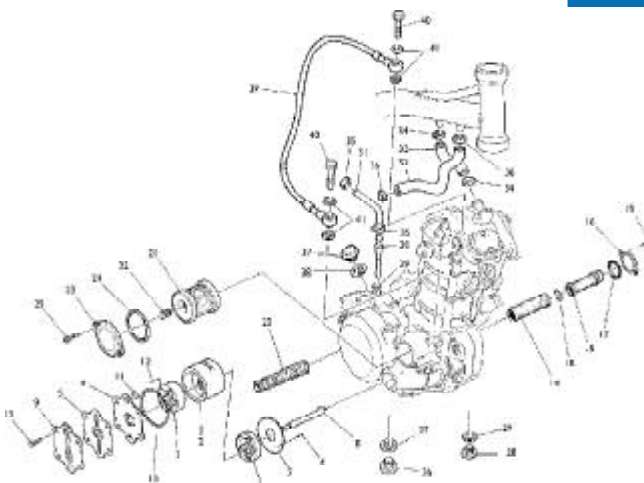

Pagina - Page - Page - Seite - Paja

48

Tavola - Drawing - Table - Bild - Tabla

12

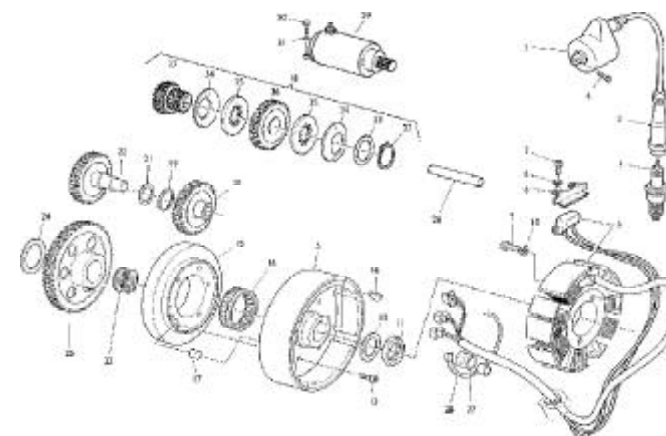

Pagina - Page - Page - Seite - Paja

52

Tavola - Drawing - Table - Bild - Tabla

13

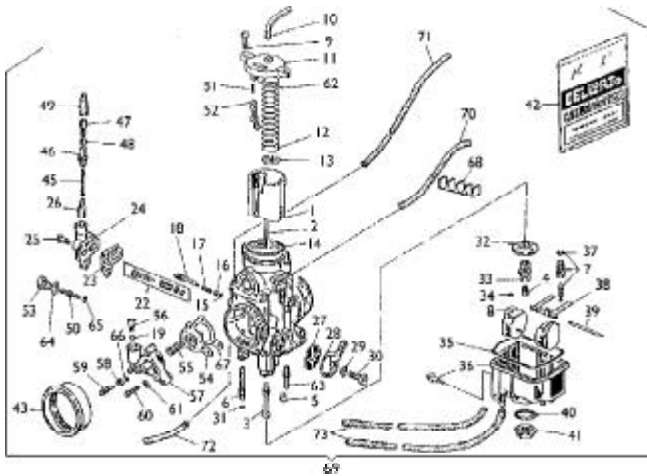

Pagina - Page - Page - Seite - Paja

56

Tavola - Drawing - Table - Bild - Tabla

13A

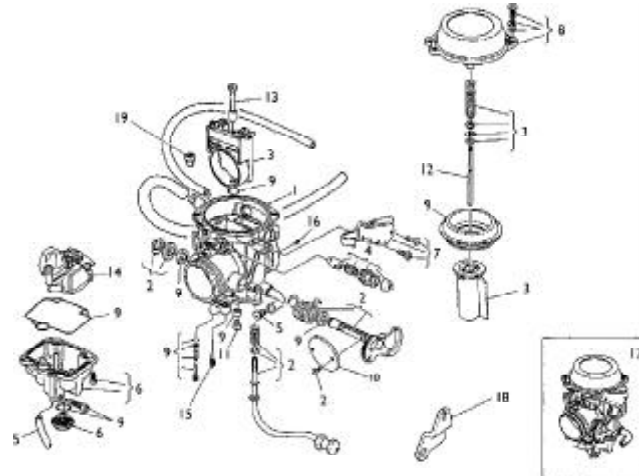

Pagina - Page - Page - Seite - Paja

62

Tavola - Drawing - Table - Bild - Tabla

14

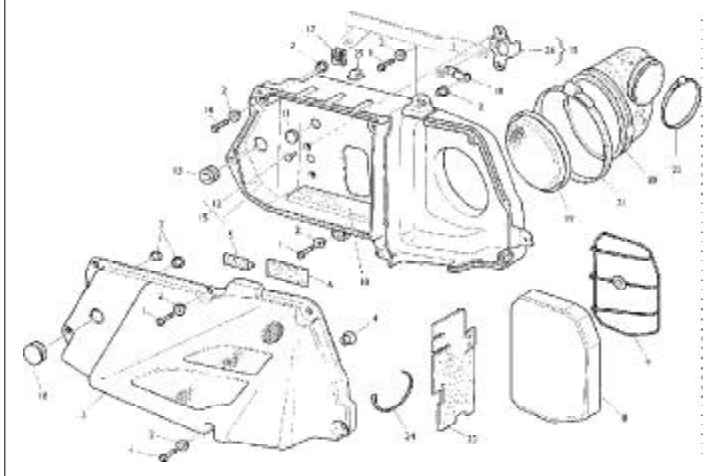

Pagina - Page - Page - Seite - Paja

64

Tavola - Drawing - Table - Bild - Tabla

15

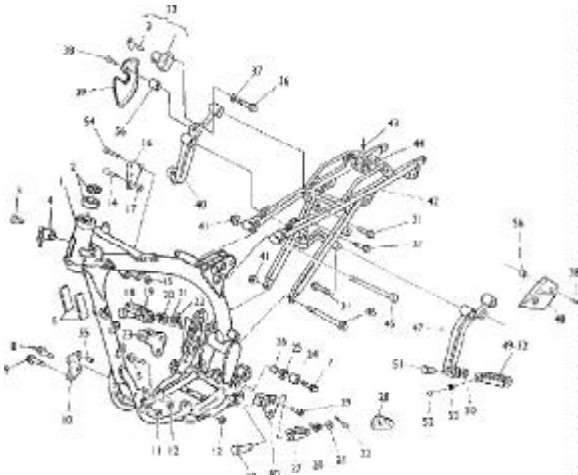

Pagina - Page - Page - Seite - Paja

66

Tavola - Drawing - Table - Bild - Tabla

16

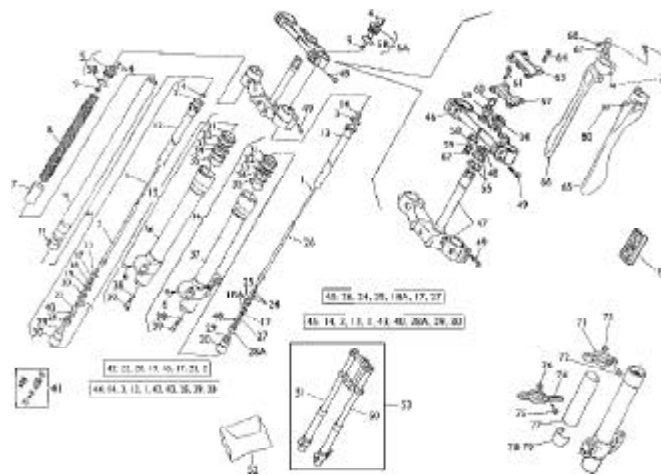

Pagina - Page - Page - Seite - Paja

70

Tavola - Drawing - Table - Bild - Tabla

17

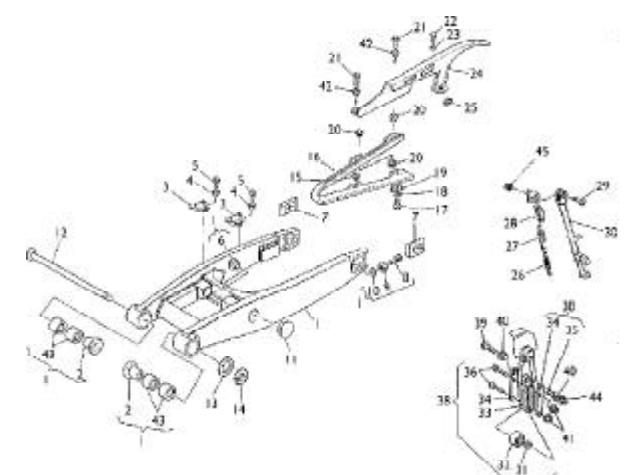

Pagina - Page - Page - Seite - Paja

78

Tavola - Drawing - Table - Bild - Tabla

17A

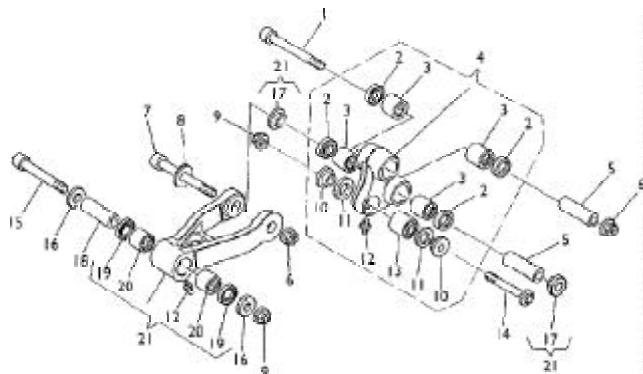

Pagina - Page - Page - Seite - Paja

82

Tavola - Drawing - Table - Bild - Tabla

18

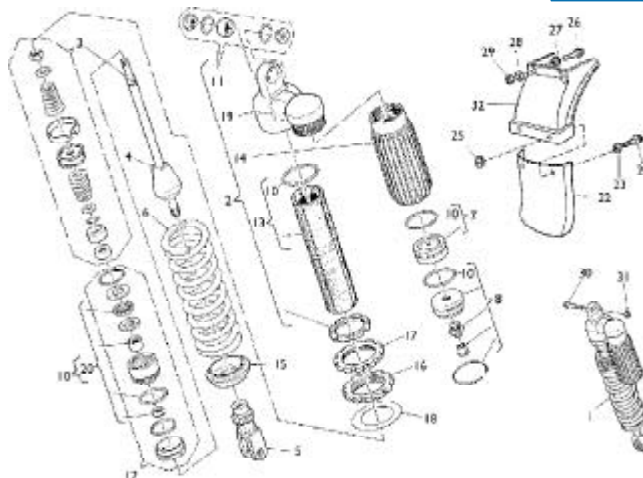

Pagina - Page - Page - Seite - Paja

84

Tavola - Drawing - Table - Bild - Tabla

19

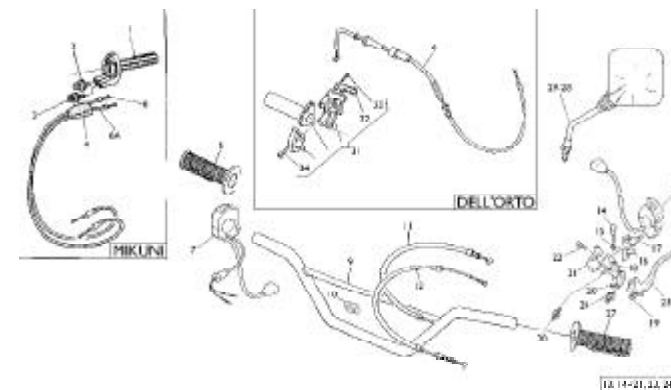

Pagina - Page - Page - Seite - Paja

86

Tavola - Drawing - Table - Bild - Tabla

20

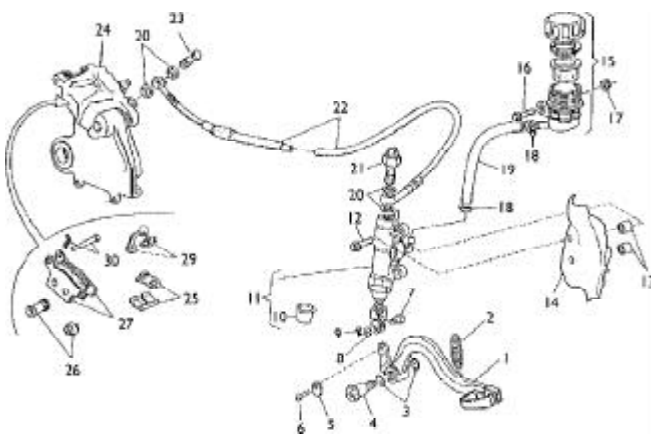

Pagina - Page - Page - Seite - Paja

90

Tavola - Drawing - Table - Bild - Tabla

21

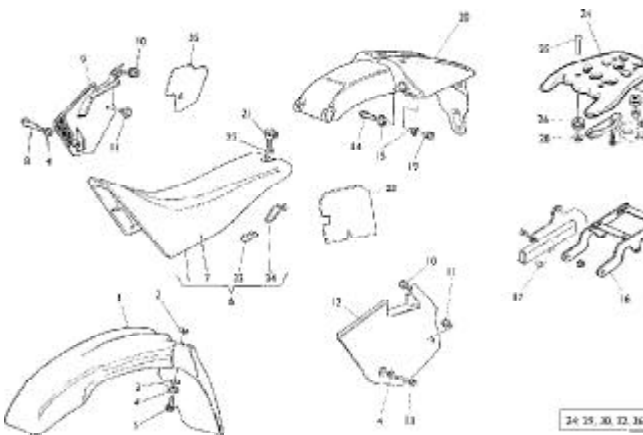

Pagina - Page - Page - Seite - Paja

92

Tavola - Drawing - Table - Bild - Tabla

22

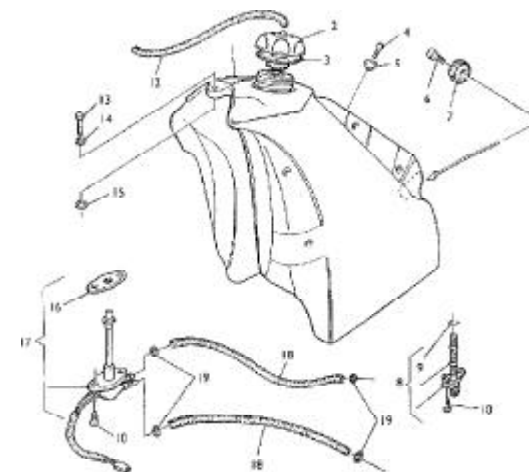

Pagina - Page - Page - Seite - Paja

96

Tavola - Drawing - Table - Bild - Tabla

23

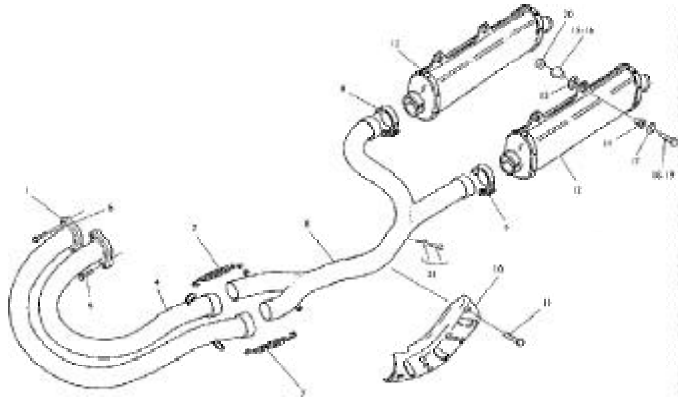

Pagina - Page - Page - Seite - Paja

98

Tavola - Drawing - Table - Bild - Tabla

24

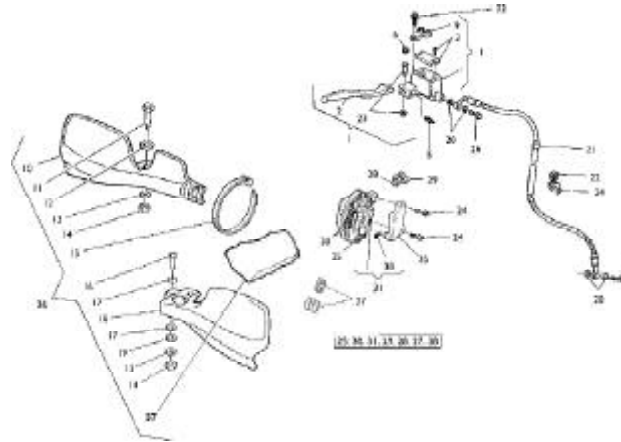

Pagina - Page - Page - Seite - Paja

100

Tavola - Drawing - Table - Bild - Tabla

24A

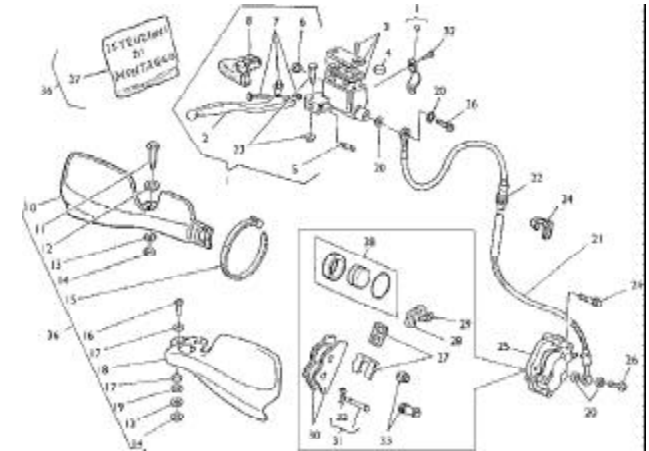

Pagina - Page - Page - Seite - Paja

104

Tavola - Drawing - Table - Bild - Tabla

25

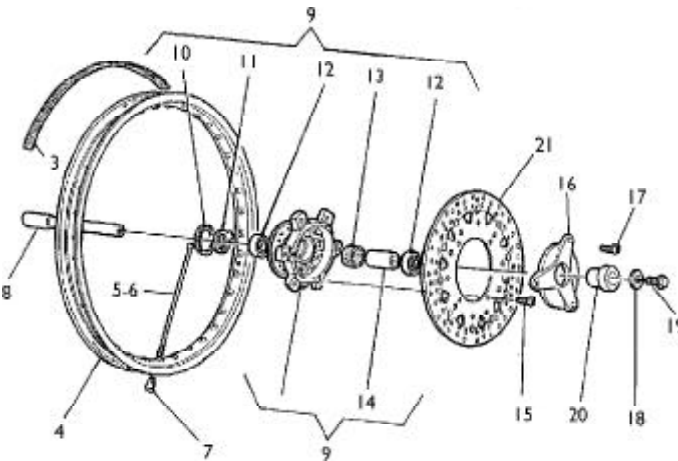

Pagina - Page - Page - Seite - Paja

108

Tavola - Drawing - Table - Bild - Tabla

25A

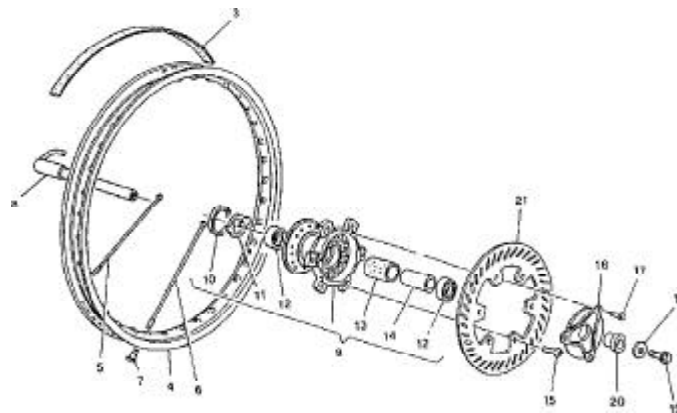

Pagina - Page - Page - Seite - Paja

110

Tavola - Drawing - Table - Bild - Tabla

26

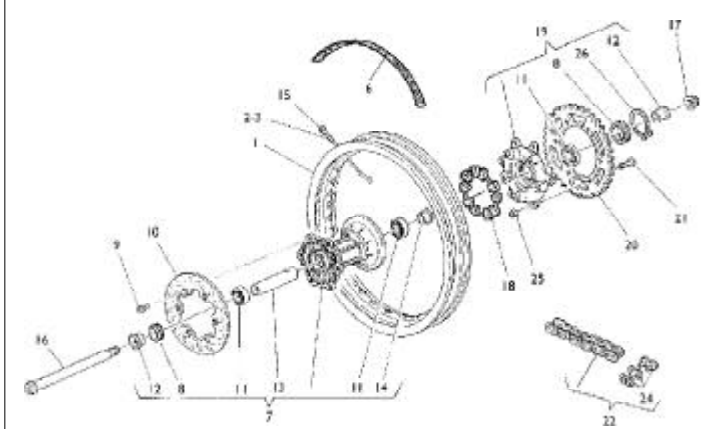

Pagina - Page - Page - Seite - Paja

112

Tavola - Drawing - Table - Bild - Tabla

27

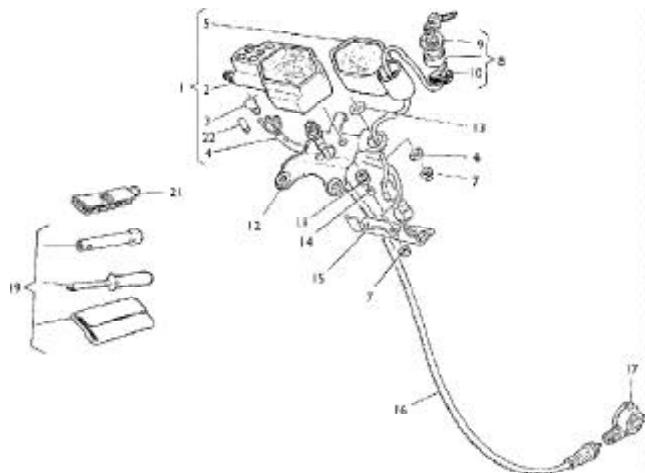

Pagina - Page - Page - Seite - Paja

116

Tavola - Drawing - Table - Bild - Tabla

28

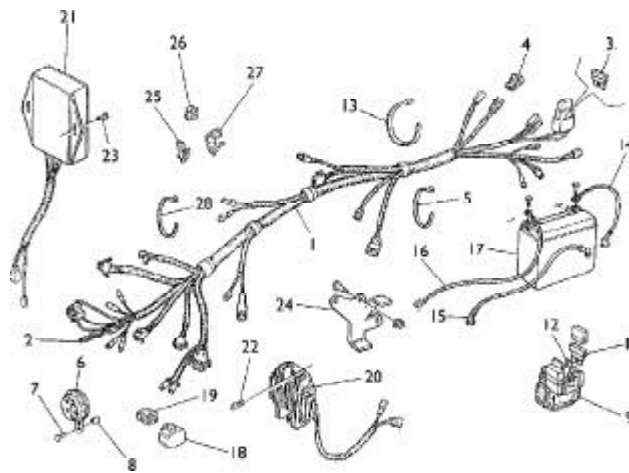

Pagina - Page - Page - Seite - Paja

118

Tavola - Drawing - Table - Bild - Tabla

28A

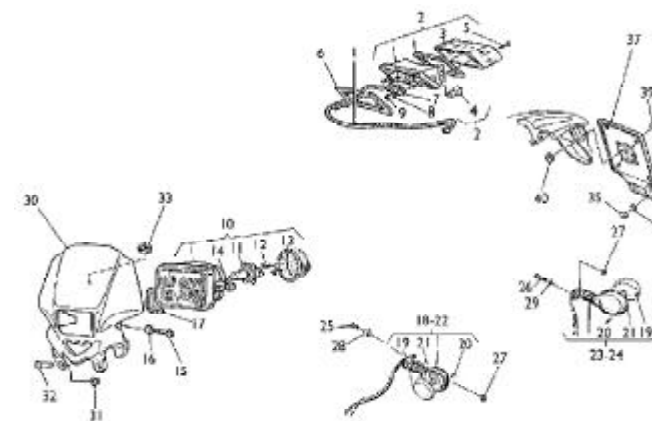

Pagina - Page - Page - Seite - Paja

120

Tavola - Drawing - Table - Bild - Tabla

29

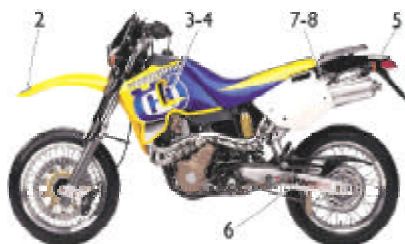

Pagina - Page - Page - Seite - Paja

124

Tavola - Drawing - Table - Bild - Tabla

29A



Pagina - Page - Page - Seite - Paja

126

Tavola - Drawing - Table - Bild - Tabla

29B

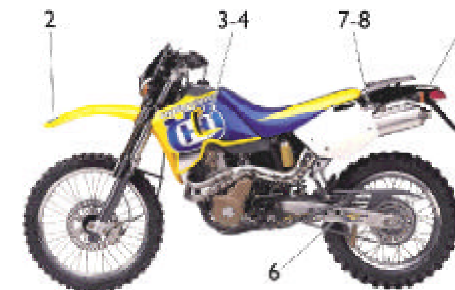

Pagina - Page - Page - Seite - Paja

128

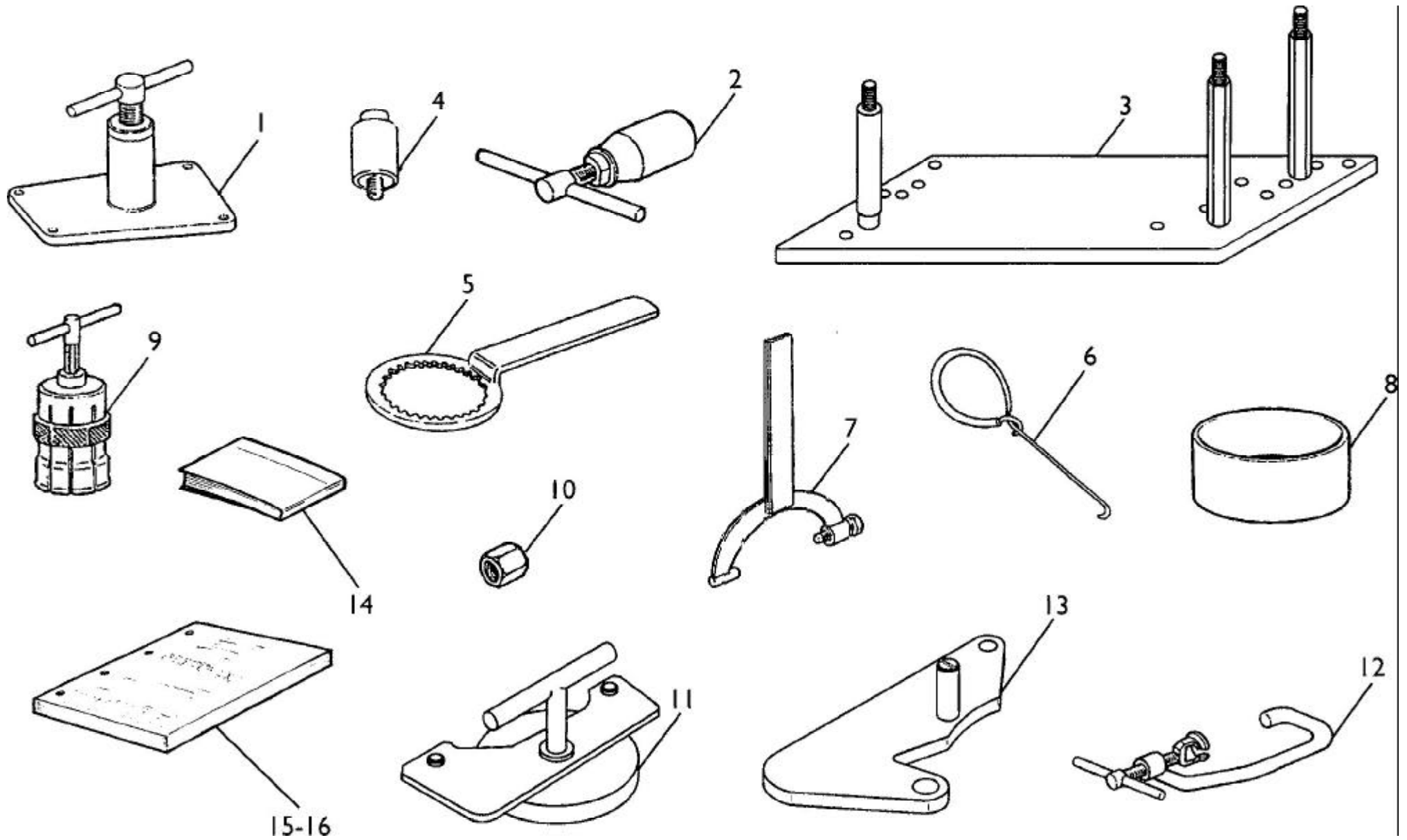

Note Notes Notas	Pos. No. N. Index Pos.	N. Cod. Code No. Nr. Code Code Nr N. Cod.	Q.tà Q.ty Q.te M.ge C.ad	DENOMINAZIONE	NAME	DESIGNATION	BESHREIBUNG	DENOMINACION	Validità Validity Validité Gültig Validez
	1	8000 89743	1	Estrattore basamento	Crankcase puller	Extracteur carter	Kurbelgehäuse-Auszieher	Extractor cárter	
	2	8000 39523	1	Estrattore volano completo	Flywheel extractor	Extracteur pour volant	Auszieher für Schwungrad	Extractor volante	
	3	8000 90662	1	Assieme supporto per montaggio motore	Support assy	Support compl.	Kpl. Halter	Soporte compl.	
	4	1514 13401	1	Estrattore braccio oscillante	Swing arm puller	Extract. bras oscillant	Schwingarm-Abzieher	Extractor brazo oscilante	
	5	8000 39524	1	Chiave di fermo mozzo frizione	Clutch hub retaining wrench	Cléf d'arret moyeau embrayage	Halterungsschlüssel der Kupplungsnahe	Llave bloquear cubo fricción	
	6	1519 84701	1	Gancio per molle	Spring hook	Crochet pour ressort	Federhaken	Gancho para resorte	
	7	8000 39522	1	Chiave smontaggio volano	Flywheel disassembling wrench	Cléf démontage volant	Schlüssel f. Demont. Schwun.	Llave desmontaje volante	
	8	8C00 52306	1	Attrezzo per montaggio pistone	Assembling piston tool	Outil montage piston	Werkzeug f. Kolbenmontage	Utensilo montaje piston	
	9	8000 90611		Estratt. cuscinetto albero motore	Crankshaft bearing extractor	Extracteur palier arbre moteur	Auszieher f. Triebwellelager	Extractor cojinete árbol a motor	
	10	8000 83254	1	Protezione albero motore estraz. volano	Flywheel puller crankshaft	Outil protection vilebrequin	Motorwelleschutz für Schwungrad	Protección eje motór por extracción volante	
	11	8000 90674	1	Attrezzo montaggio accensione	Ignition ass. tool	Outil mont. ignition	Werkzeug Montagezündung	Ut. montaje encend.	
	12	8000 39521	1	Attrezzo mont.- smont. valvole	Valves ass. and rem. tool	Outil pour mont. dem. soup.	Werkzeug für Ventilmontage	Ut. mantaje- desm. válvulas	
	13	8000 90875	1	Dima per fasatura al P.M.S.	Ignition control tool	Outil pour surveillance allumage	Werkzeug zur Kt. der Zündung	Utensilo control fase	
D	14	8000 A4260	1	Libretto uso e manutenzione	Owner's manual	Emploi d'entretien	Betriebsanleitung	Manual de uso y mantenimiento	
R	15	8000 A1169	1	Manuale d'officina	Workshop manual	Manuel de service	Werkstatthandbuch	Manual de oficina	
R	16	8000 A4261	1	Catalogo "Parti di Ricambio"	"SPARE PARTS" catalog	Catalogue "PIECES DE RECHANGE"	ERSATZTEILKATALOG	Catalogo "PIEZAS DE REPUESTO"	

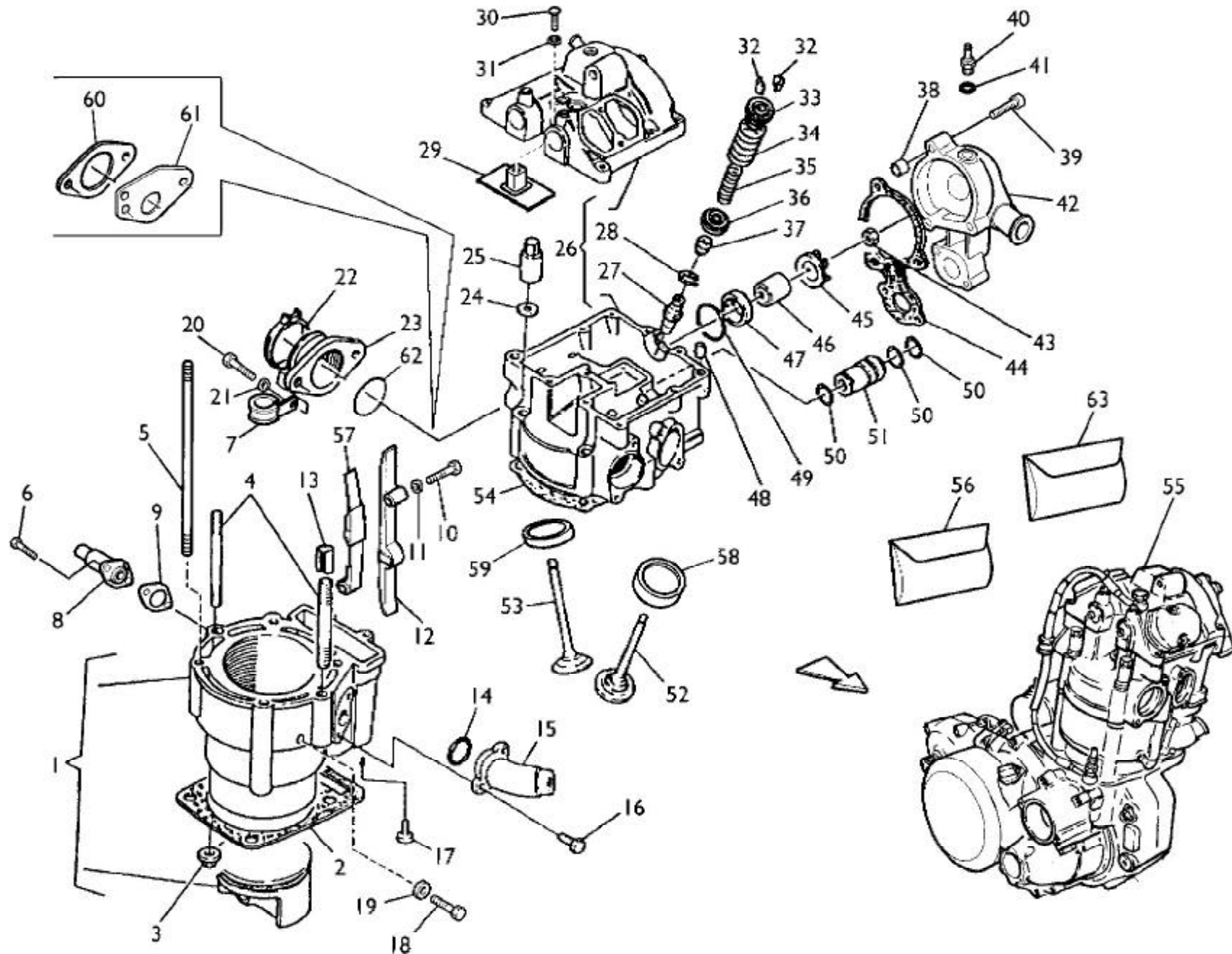

Note Notes Notas	Pos. No. N. Index Pos.	N. Cod. Code No. Nr. Code Code Nr N. Cod.	Q.tà Q.te M.ge C.ad	DENOMINAZIONE	NAME	DESIGNATION	BESHREIBUNG	DENOMINACION	Validità Validity Validité Gültig Validez
	1	8000 97972	1	Cilindro completo	Cylinder assy	Cylindre compl.	Zylinder kpl.	Cilindro compl.	
A	1	8000 98541	1	Cilindro completo	Cylinder assy	Cylindre compl.	Zylinder kpl.	Cilindro compl.	
	2	1615 40702	1	Guarnizione	Gasket	Guarniture	Dichtung	Junta	
	3	61N1 15195	2	Dado	Nut	Ecrou	Muller	Tuerca	
	4	1615 33201	2	Prigioniero (L= 84 mm)	Stud bolt (L= 84 mm)	Prisonnier (L= 84 mm)	Stiftschraube (L= 84 mm)	Prisionero (L= 84 mm)	
	5	8000 81650	4	Prigioniero (L= 180mm)	Studbolt (L= 180 mm)	Prisonnier (L= 180 mm)	Stiftschraube (L= 180 mm)	Prisionero (L= 180 mm)	
	6	8000 62728	2	Vite	Screw	Vis	Schraube	Tornillo	
	7	8000 88167	1	Collare fermatubo	Clamp	Collier	Schelle	Abrazadera	
	8	8000 77108	1	Tenditore completo	Complete tensioner	Tendeur complet	Zylinderspanner	Tensor completo	
	9	8000 77109	1	Guarnizione	Gasket	Garniture	Dichtung	Junla	
	10	1615 35902	2	Vite	Screw	Vis	Schraube	Tornillo	
	11	8000 45194	2	Rosetta piana	Washer	Rondella	Scheibe	Arandela	
	12	8000 81151	1	Pattino catena	Chain slider	Glissière	Gleitbahn	Plato cadena	
	13	8000 47708	2	Spina elastica	Pin	Goupille	Stift	Clavija	
	14	8000 19789	1	Anello OR	O-Ring	Bague OR	O-Ring	Anillo OR	
	15	80A0 66222	1	Raccordo	Union	Raccord	Anschluss	Empalme	
	16	8000 62727	2	Vite	Screw	Vis	Schraube	Tornillo	
	17	60N1 02511	2	Vite	Screw	Vis	Schraube	Tornillo	
	18	8000 62725	1	Vite scarico acqua	Screw	Vis	Schraube	Tornillo	
	19	8A00 15960	1	Guarnizione per vite	Gasket	Guarniture	Dichtung	Junla	
	20	60N1 02557	2	Vite (M8x30mm)	Screw (M8x30mm)	Vis (M8x30mm)	Schraube (M8x30mm)	Tornillo (M8x30mm)	
	21	8000 08536	2	Rosetta piana	Washer	Rondelle	Scheibe	Arandela	
#	22	8000 33279	1	Fascetta	Clamp	Collier	Schelle	Banda	
§	22	8000 60558	1	Fascetta	Clamp	Collier	Schelle	Banda	
#	23	8000 85388	1	Raccordo	Union	Raccord	Anschluss	Empalme	
§	23	8000 87139	1	Raccordo	Union	Raccord	Anschluss	Empalme	
	24	8000 69156	4	Rosetta piana	Washer	Rondella	Scheibe	Arandela	
	25	1615 35101	4	Dado	Nul	Ecrou	Mutter	Tuerca	
	26	8000 81645	1	Testa compl. di coperchio	Head and cover assy	Culasse et couvercle compl.	Zylinderkopf und Dekel kpl.	Culata y tapa compl.	
	27	8A00 80661	4	Guida valvola (+ 0,025 mm)	Valve guide (+ 0,025 mm)	Guide-soupape (+ 0,025 mm)	Ventilführung (+ 0,025 mm)	Guía-válvula (+ 0,025 mm)	
	27	8B00 80661	4	Guida valvola (+ 0,050 mm)	Valve guide (+ 0,050 mm)	Guide-soupape (+ 0,050 mm)	Ventilführung (+ 0,050 mm)	Guía-válvula (+ 0,050 mm)	
	28	8000 59940	4	Anello di arresto	Snap ring	Bague d'arrêt	Haltering	Anillo elástico de retención	

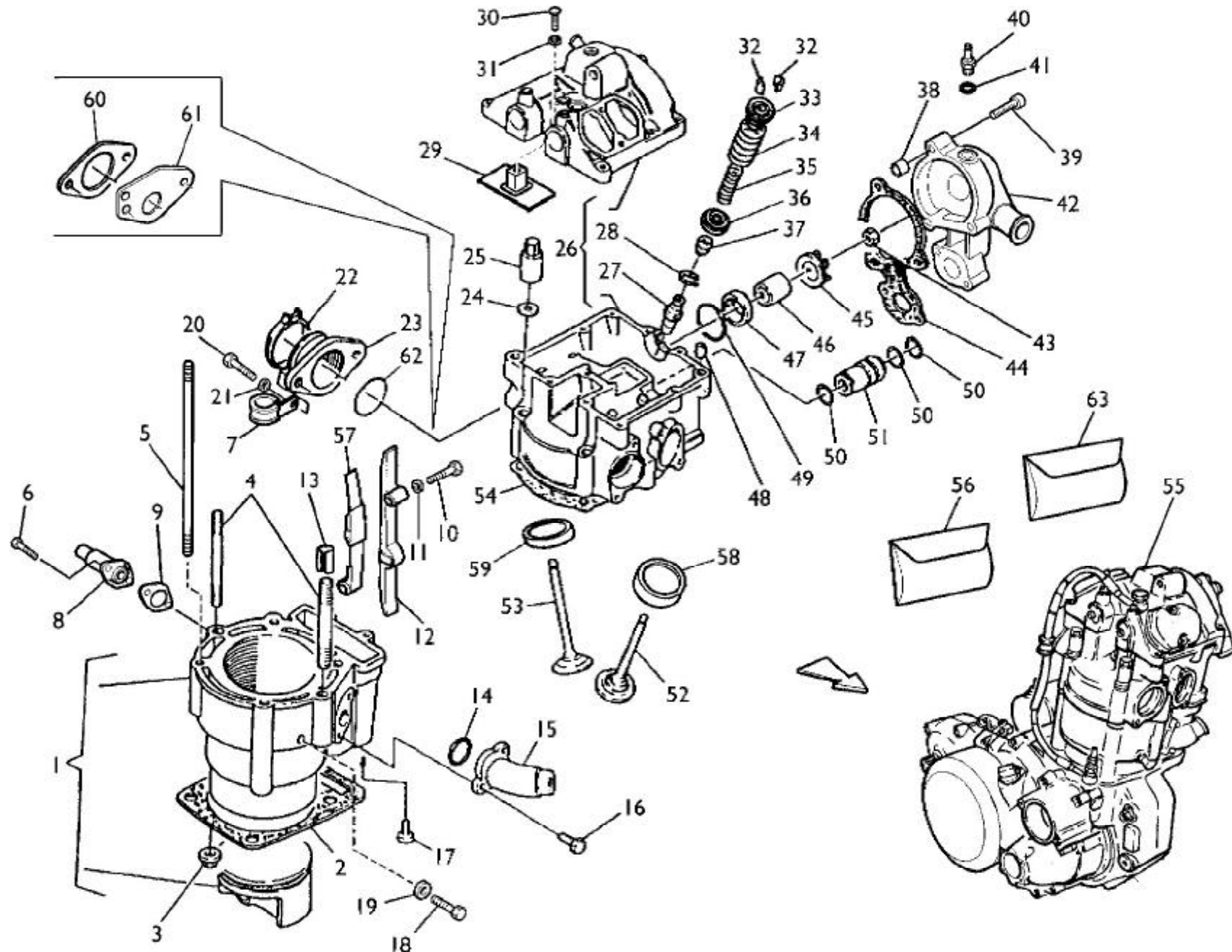

Note Notes Notas	Pos. No. N. Index Pos.	N. Cod. Code No. Nr. Code Code Nr N. Cod.	Q.tà Q.ty Q.te M.ge C.ad	DENOMINAZIONE	NAME	DESIGNATION	BESHREIBUNG	DENOMINACION	Validità Validity Validité Gültig Validez
	29	8000 73482	1	Lamierino decant. vapori olio	Plate	Plaque	Plättchen	Laminilla	
	30	8000 14837	1	Vite	Screw	Vis	Schraube	Tornillo	
	31	62N0 15672	1	Rosetta di tenuta	Washer	Rondelle	Scheibe	Arandela	
	32	8000 77425	8	Semicono	Half cone	Demi-cône	Halb Kegel	Semi-cono	
	33	8000 81799	4	Scodellino superiore	Cup	Cuvette	Teller	Cubela	
	34	8000 82205	4	Molla esterna	Spring	Ressort	Feder	Resorte	
	35	8000 82204	4	Molla interna	Spring	Ressort	Feder	Resorte	
	36	8000 81647	4	Scodellino inferiore	Cup	Cuvette	Teller	Cubeta	
	37	8000 75584	4	Anello di tenuta	Seal ring	Bague d'étanchéité	Dichtungsring	Anillo de retención	
A	37	1615 30301	4	Anello di tenuta	Seal ring	Bague d'étanchéité	Dichtungsring	Anillo de retención	
	38	1617 95501	2	Bussola	Bushing	Douille	Buchse	Manguito	
	39	8000 62730	5	Vite	Screw	Vis	Schraube	Tornillo	
	40	8000 66395	1	Raccordo	Union	Raccord	Anschluss	Empalme	
	41	8A00 15960	1	Rosetta	Washer	Rondelle	Scheibe	Arandela	
	42	80B0 75766	1	Corpo pompa	Pump body	Corps pompe	Pumpenkörper	Corpo bomba	
	43	8000 42278	1	Dado	Nut	Ecrou	Mutter	Tuerca	
	44	8A00 63644	1	Guarnizione	Gasket	Garniture	Dichtung	Junta	
	45	8A00 60415	1	Girante	Rotor	Couronne	Laufrad	Rotor	
	46	8000 53339	1	Anello di tenuta	Seal ring	Bague d'étanchéité	Dichtungsring	Anillo de retención	
	47	8000 63817	1	Bussola	Bushing	Douille	Buchse	Manguito	
	48	1611 70801	2	Bussola	Bushing	Douille	Buchse	Manguito	
	49	8000 59942	1	Anello OR	O-Ring	Bague OR	O-Ring	Anillo OR	
	50	8000 18422	3	Anello OR	O-Ring	Bague OR	O-Ring	Anillo OR	
	51	8A00 78765	1	Tubetto	Pipe	Tuyau	Rohr	Tubo	
	52	8000 80532	2	Valvola scarico	Exhaust valve	Soupape d'échappement	Auslass-Ventil	Válvula de escape	
	53	8000 80531	2	Valvola aspirazione	Inlet valve	Soupape admission	Einlass-Ventil	Válvula aspiración	
	54	8000 64726	1	Guarnizione	Gasket	Garniture	Dichtung	Junta	
SS	55	8000 A1373	1	Assieme motore	Engine assy	Moteur complet	Motor Kpl.	Motor compl.	
TT	55	8000 A1364	1	Assieme motore	Engine assy	Moteur complet	Motor Kpl.	Motor compl.	
	56	8000 91260	1	Gruppo guarnizioni motore	Engine gasket set	Groupe garnitures moteur	Dichtungssatz	Grupo juntas motor	
	57	8000 81149	1	Pattino catena	Chain slider	GlissiÅre	Gleitbahn	Plato cadena	
	58	8A00 80669	2	Sede valvola di scarico (magg. 0,03 mm)	Exhaust valve seat (+0,03 mm)	Siege soupape échapp. (+0,03 mm)	Auslass-sitzring (+0,03 mm)	Alojamento valvula escape (+0,03 mm)	

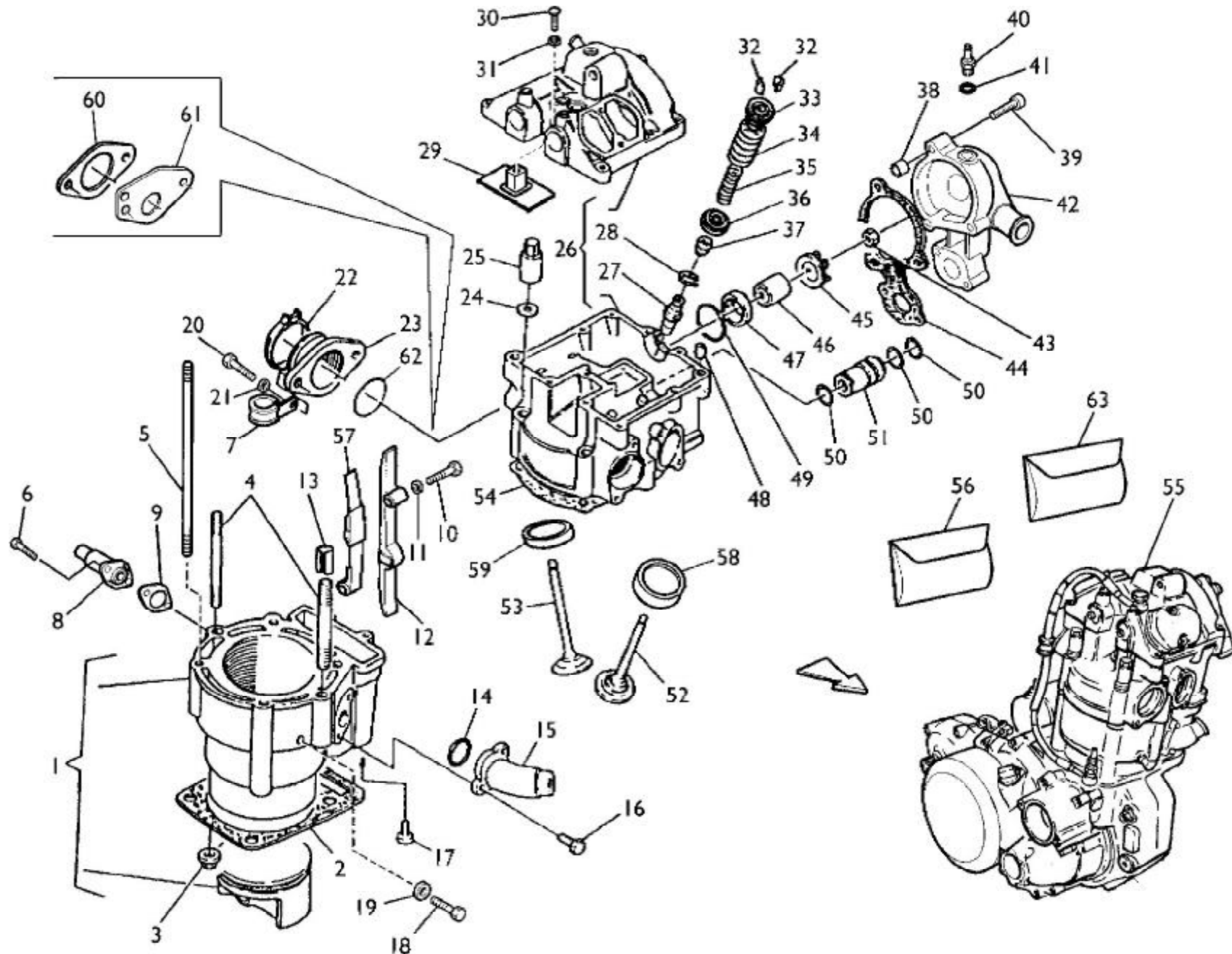

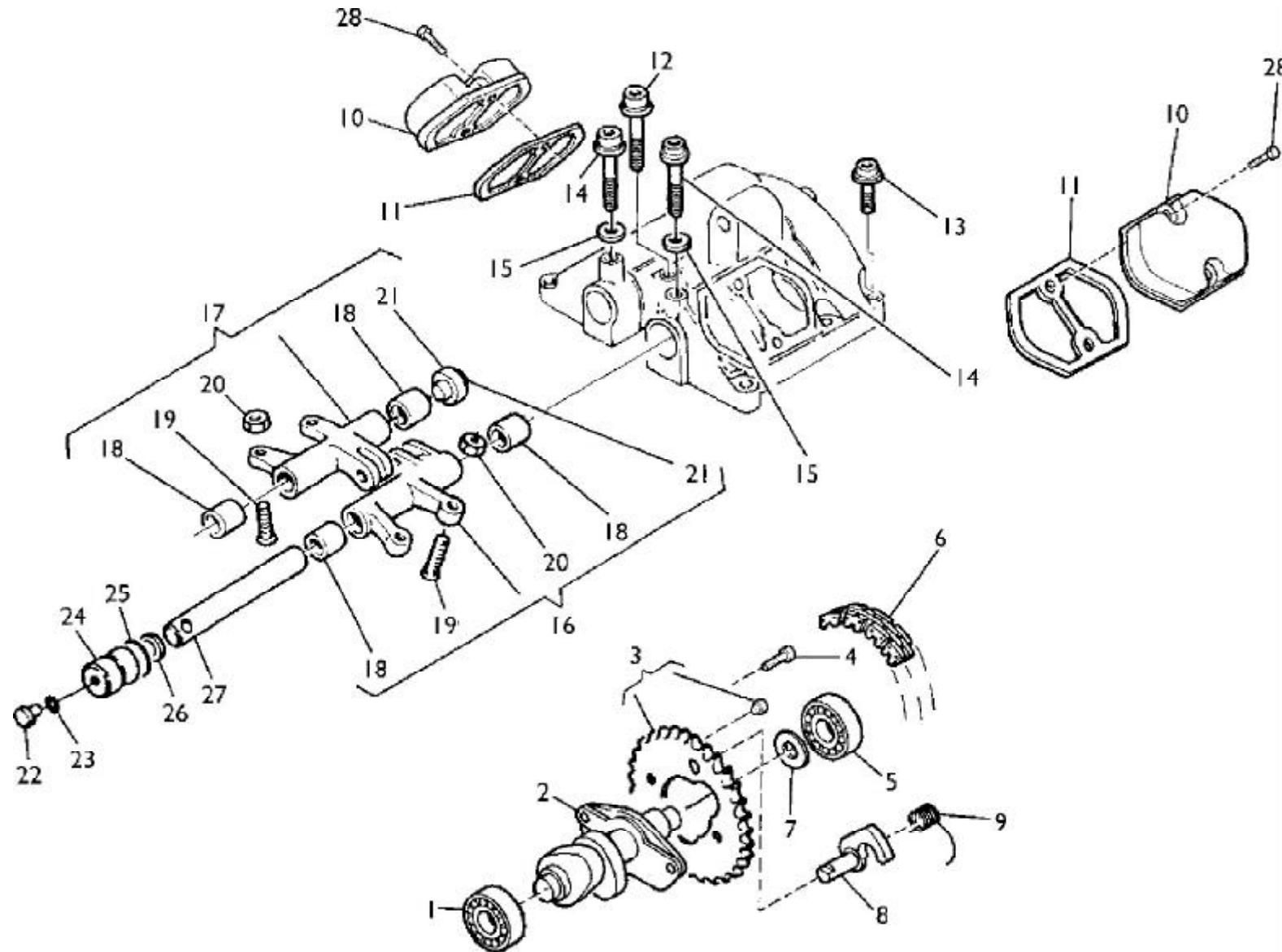

Note Notes Notas	Pos. No. N. Index Pos.	N. Cod. Code No. Nr. Code Code Nr N. Cod.	Q.tà Q.ty Q.te M.ge C.ad	DENOMINAZIONE	NAME	DESIGNATION	BESCHREIBUNG	DENOMINACION	Validità Validity Validité Gültig Validez
	3	8000 93923	1	Ingranaggio condotto (Z = 42)	Driven gear (Z = 42)	Engranage conduit (Z = 42)	Zahnrad (Z = 42)	Engranaje conducto (Z = 42)	
	4	1615 26602	2	Vite	Screw	Vis	Schraube	Tornillo	
	5	8A00 02124	1	Cuscinetto (ø12xø32x10mm)	Bearing (ø12xø32x10mm)	Roulement (ø12xø32x10mm)	Lager (ø12xø32x10mm)	Cojinete (ø12xø32x10mm)	
	6	8000 58541	1	Catena distribuzione	Chain	Chaîne	Kette	Cadena	
	7	8F00 10789	1	Rosetta	Washer	Rondelle	Scheibe	Arandela	
	8	8000 93924	1	Alzavalvola	Valve lifter	Levée de soupape	Ventilauflheber	Alza valvula	
	9	8000 72290	1	Molla	Spring	Ressort	Feder	Resorte	
	10	8000 73287	2	Coperchio registri	Cover	Couvercle	Deckel	Tapa	
	11	1615 03601	2	Guarnizione	Gasket	Garniture	Dichtung	Junta	
	12	8000 62731	1	Vite (L = M6x45 mm)	Screw (L = M6x45 mm)	Vis (L = M6x45 mm)	Schraube (L = M6x45 mm)	Tornillo (L = M6x45 mm)	
	13	8000 62730	8	Vite (L = M6x30 mm)	Screw (L = M6x30 mm)	Vis (L = M6x30 mm)	Schraube (L = M6x30 mm)	Tornillo (L = M6x30 mm)	
	14	8000 96796	2	Vite (L = M6x60 mm)	Screw (L = M6x60 mm)	Vis (L = M6x60 mm)	Schraube (L = M6x60 mm)	Tornillo (L = M6x60 mm)	
	15	8000 64988	2	Rosetta	Washer	Rondelle	Scheibe	Arandela	
	16	8000 81649	1	Bilancere di scarico completo	Exhaust rocker-arm assy	Culbuteur échappem. compl.	Kipphebel Auspuffrohr kpl.	Balancín de escape compl.	
	17	8000 81648	1	Bilancere di aspirazione compl.	Inlet rocker-arm assy	Culbuteur d'aspiration compl.	Kipphebel Ansaugen kpl.	Balancín de aspiración compl.	
	18	1615 04301	4	Bussola	Bushing	Douille	Buchse	Manguito	
	19	8A00 79058	4	Vite di registro	Adjusting screw	Vis de réglage	Verstellungsschraube	Tornillo de regulación	
	20	1615 15601	4	Dado	Nut	Ecrou	Mutter	Tuerca	
	21	1615 04501	2	Cuscinetto a rullini	Needle bearing	Roulement à aiguilles	Nadelkäfig	Cojinete de rodillos	
	22	60N1 02927	2	Vite	Screw	Vis	Schraube	Tornillo	
	23	8A00 15960	2	Rosetta piana	Washer	Rondelle	Scheibe	Arandela	
	24	1615 39301	2	Tappo	Plug	Bouchon	Verschluss	Tapón	
	25	8000 59939	2	Anello OR	O-Ring	Bague OR	O-Ring	Anillo OR	
	26	8000 50322	2	Rosetta di rasamento (0,3 mm)	Washer (0,3 mm)	Rondelle (0,3 mm)	Scheibe (0,3 mm)	Arandela (0,3 mm)	
	26	8A00 50322	2	Rosetta di rasamento (0,4 mm)	Washer (0,4 mm)	Rondelle (0,4 mm)	Scheibe (0,4 mm)	Arandela (0,4 mm)	
	26	8B00 50322	2	Rosetta di rasamento (0,5 mm)	Washer (0,5 mm)	Rondelle (0,5 mm)	Scheibe (0,5 mm)	Arandela (0,5 mm)	
	26	8C00 50322	2	Rosetta di rasamento (0,6 mm)	Washer (0,6 mm)	Rondelle (0,6 mm)	Scheibe (0,6 mm)	Arandela (0,6 mm)	
	27	1615 04201	2	Perno	Pin	Pivot	Bolzen	Perno	
	28	8000 62728	4	Vite	Screw	Vis	Schraube	Tornillo	
E	1	8000 84824	1	Ass. albero motore	Crankshaft assy	Vilebrequin compl.	Kurbewelle kpl.	Cigüeñal compl.	
	1	8000 98007	1	Ass. albero motore	Crankshaft assy	Vilebrequin compl.	Kurbewelle kpl.	Cigüeñal compl.	

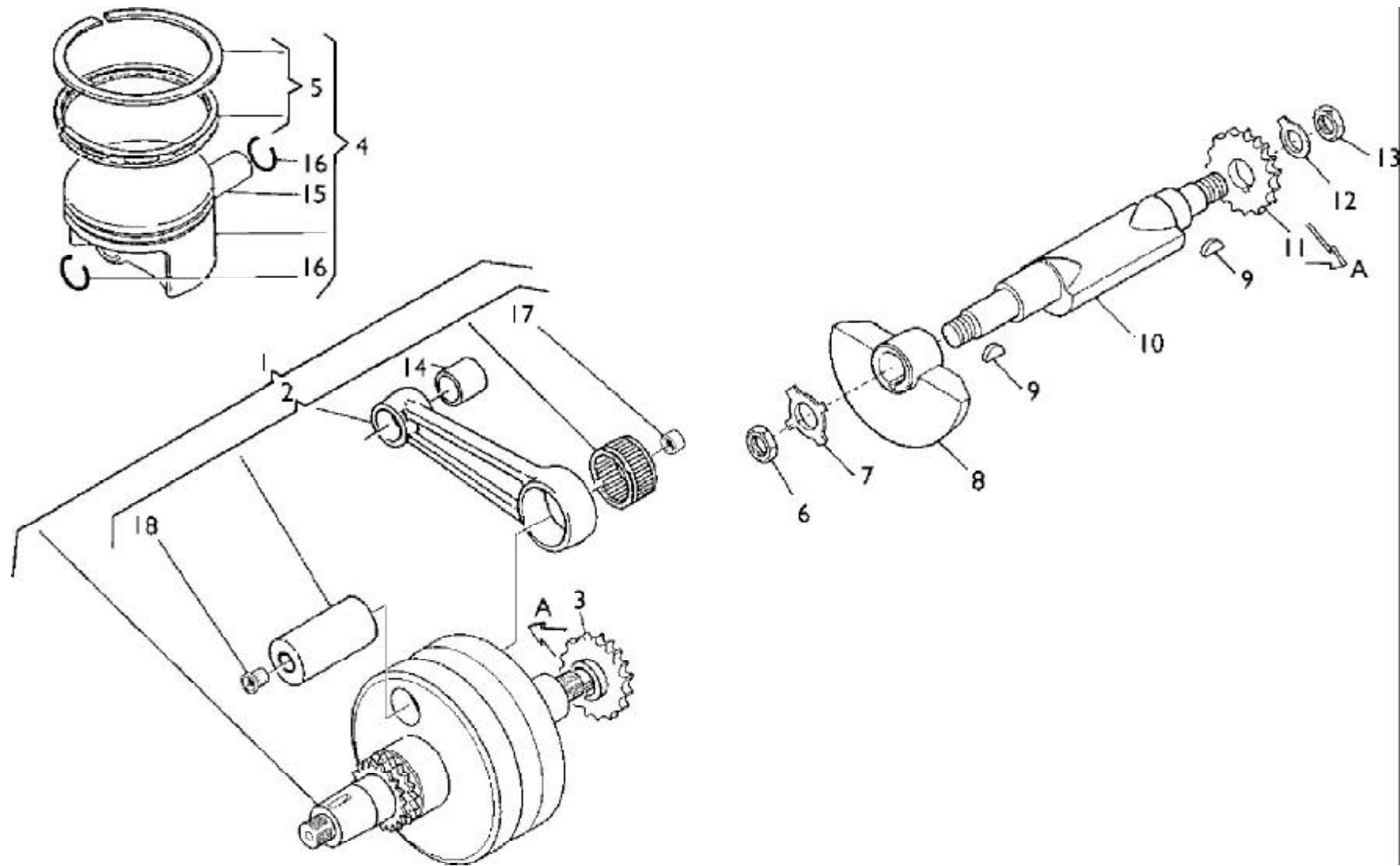

Note Notes Notas	Pos. No. N. Index Pos.	N. Cod. Code No. Nr. Code Code Nr N. Cod.	Q.tà Q.ty Q.te M.ge C.ad	DENOMINAZIONE	NAME	DESIGNATION	BESHREIBUNG	DENOMINACION	Validità Validity Validité Gültig Validez
E	2	8000 85020	1	Biella completa	Connecting rod compl.	Bielle compl.	Pleuelstange kpl.	Biela motor completa	
	2	8000 98006	1	Biella completa	Connecting rod compl.	Bielle compl.)	Pleuelstange kpl. (Biela motor completa	
	3	8000 71021	1	Ruota conduttrice (Z = 39)	Gear (Z = 39)	Engrenage (Z = 39)	Zahnrad (Z = 39)	Engranaje (Z = 39)	
	4	8000 96604	1	Pistone completo (ø98mm)	Compl. piston (ø98mm)	Piston complet (ø98mm)	Kolben, kpl. (ø98mm)	Pistón completo (ø98mm)	
	5	8A00 97973	1	Kit segmenti	Circlip kit	Kit segment	Kolbenring kit	Kit segmento	
	6	8000 71031	1	Dado	Nut	Ecrou	Mutter	Tuerca	
	7	8000 71034	1	Rosetta di sicurezza	Washer	Rondelle	Scheibe	Arandela	
	8	8000 71024	1	Massa per contralbero	Layshaft	Arbre de bal.	Worgelegewelle	Contra-eje	
	9	1513 71301	2	Linguetta	Woodruff key	Clé woodruf	Federkeil	Lengüeta	
	10	8000 71023	1	Contralbero	Counter-shaft	Arbre de bal.	Vorgelegewelle	Contra-eje	
	11	8000 71020	1	Ruota condotta (Z = 39)	Gear (Z = 39)	Engrenage (Z = 39)	Zahnrad (Z = 39)	Engranaje (Z = 39)	
	12	8000 71035	1	Rosetta di sicurezza	Washer	Rondelle	Scheibe	Arandela	
	13	8000 03170	1	Dado	Nut	Ecrou	Mutter	Tuerca	
	14	8000 88073	1	Cuscinetto piede di biella	Bearing for small end rod	Roulement pour pied de bielle	Nadelkäfig für Pleuelange	Cojinete para cuello de biela	
	15	8A00 67823	1	Spinotto	Gudgeon	Axe de piston	Kolbenbolzen	Clavija par piston	
	16	8000 67824	2	Anello ritegno spinotto	Seeger Ring	Bague seeger	Seeger Ring	Anillo seeger	
	17	8000 84826	1	Tappo	Plug	Bouchon	Verschluss	Tapòn	
	18	8000 45395	1	Tappo filettato	Plug	Bouchon	Verschluss	Tapòn	
SS	1	8000 87119	1	Radiatore Dx.	R.H. radiator	Radiateur D.	R., Kühler	Radiador derech.	
TTE	1	80A0 67186	1	Radiatore Dx. (&)	R.H. radiator (&)	Radiateur D. (&)	R., Kühler (&)	Radiador derech. (&)	

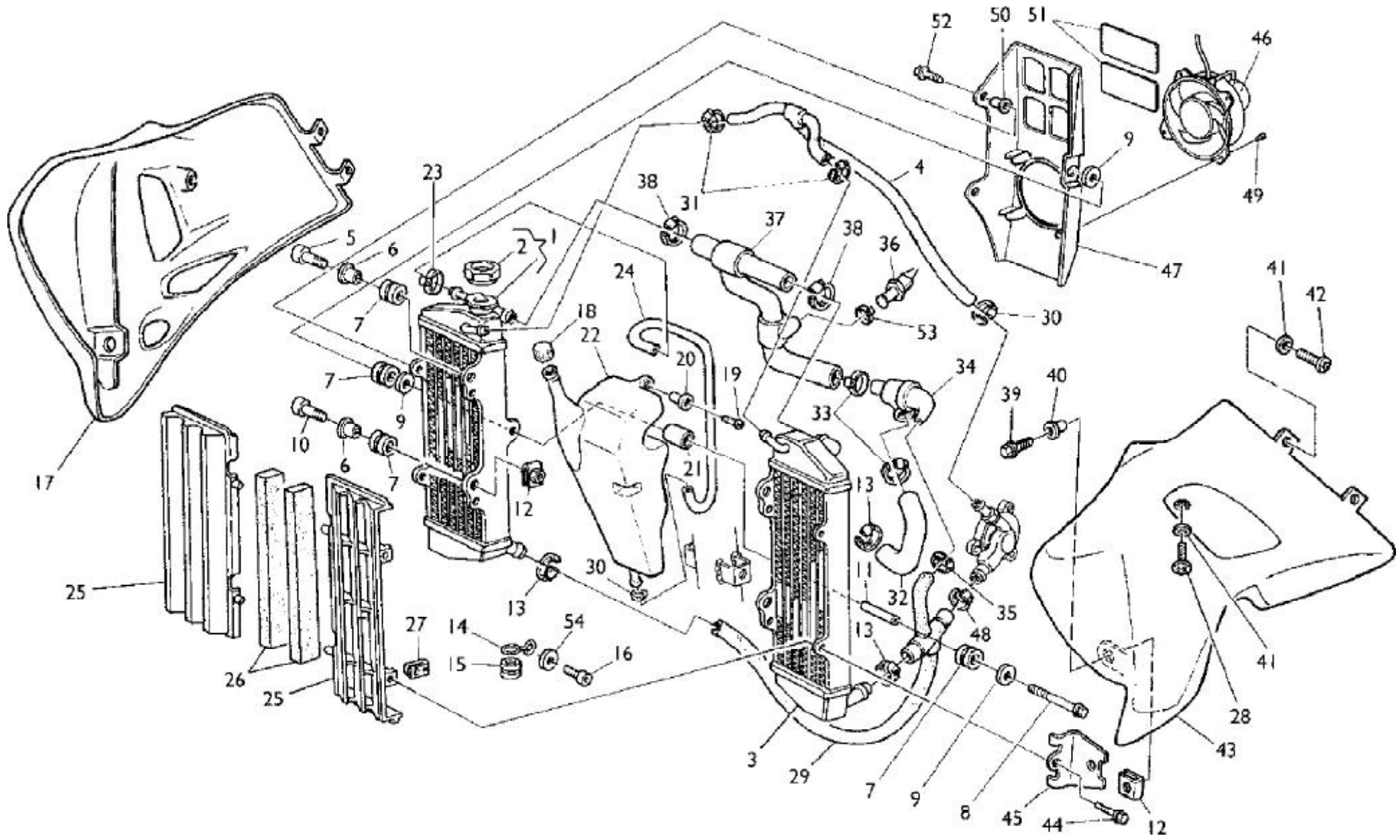

Note Notes Notas	Pos. No. N. Index Pos.	N. Cod. Code No. Nr. Code Code Nr N. Cod.	Q.tà Q.ty Q.te M.ge C.ad	DENOMINAZIONE	NAME	DESIGNATION	BESHREIBUNG	DENOMINACION	Validità Validity Validité Gültig Validez
TT	1	8000 87119	1	Radiatore Dx. (@)	R.H. radiator (@)	Radiateur D. (@)	R., Kühler (@)	Radiador derech. (@)	
SS	2	8000 79077	1	Tappo	Plug	Bouchon	Verschluss	Tapón	
TTE	2	8000 43714	1	Tappo (&)	Plug (&)	Bouchon (&)	Verschluss (&)	Tapón (&)	
TT	2	8000 79077	1	Tappo (@)	Plug (@)	Bouchon (@)	Verschluss (@)	Tapón (@)	
SS	3	8000 87120	1	Radiatore Sx.	L.H. radiator	Radiateur G.	L., Kühler	Radiador izrdo.	
TTE	3	80A0 66800	1	Radiatore Sx. (&)	L.H. radiator (&)	Radiateur G. (&)	L., Kühler (&)	Radiador izrdo. (&)	
TT	3	8000 87120	1	Radiatore Sx. (@)	L.H. radiator (@)	Radiateur G. (@)	L., Kühler (@)	Radiador izrdo. (@)	
SS	4	8A00 66850	1	Tubetto sfiato	Hose	Tuyau	Rohr	Tube	
TTE	4	8000 66850	1	Tubetto sfiato (&)	Hose (&)	Tuyau (&)	Rohr (&)	Tube (&)	
TT	4	8A00 66850	1	Tubetto sfiato (@)	Hose (@)	Tuyau (@)	Rohr (@)	Tube (@)	
	5	8000 62725	2	Vite	Screw	Vis	Schraube	Tornillo	
	6	8000 59802	4	Bussola	Bushing	Douille	Buchse	Manguito	
	7	8000 59803	6	Gommino	Rubber pad	Pièce caoutchouc	Gummstück	Junta de goma	
	8	60N1 02525	1	Vite (M6x100 mm)	Screw (M6x100 mm)	Vis (M6x100 mm)	Schraube (M6x100 mm)	Tornillo (M6x100 mm)	
	9	8000 59801	3	Rosetta piana	Washer	Rondelle	Scheibe	Arandela	
	10	8000 62728	2	Vite (M6x20 mm)	Screw (M6x20 mm)	Vis (M6x20 mm)	Schraube (M6x20 mm)	Tornillo (M6x20 mm)	
	11	8000 66858	1	Distanziale	Spacer	Entretoise	Distanzstück	Separador	
	12	8000 46893	2	Dado a graffetta	Nut	Ecrou	Mutter	Tuerca	
	13	8B00 99475	3	Fascetta	Clamp	Collier	Schelle	Banda	
	14	8000 87859	1	Anello di guida per tubi	Ring	Bague	Ring	Anillo	
	15	8000 67449	1	Gommino	Rubber pad	Pièce caoutchouc	Gummstück	Junta de goma	
	16	8000 62725	1	Vite	Screw	Vis	Schraube	Tornillo	
	17	80D0 87061	1	Convogliatore Dx. (codice colore F)	Right side panel (color code F)	Flanc droit (code couleur F)	Rechte Flanke (Code Farbe F)	Lateral derecho (còdigo colòr F)	
	17	80G0 87061	1	Convogliatore Dx. (codice colore E)	Right side panel (color code E)	Flanc droit (code couleur E)	Rechte Flanke (Code Farbe E)	Lateral derecho (còdigo colòr E)	
	18	8000 40427	1	Tappo	Plug	Bouchon	Verschluss	Tapón	
	19	8000 62726	1	Vite (M6x14 mm)	Screw (M6x14 mm)	Vis (M6x14 mm)	Schraube (M6x14 mm)	Tornillo (M6x14 mm)	
	20	8000 45495	1	Bussola	Bushing	Douille	Buchse	Manguito	
	21	8000 84704	1	Tubazione	Pipe	Tuyau	Schlauch	Tube	
	22	8000 84706	1	Serbatoio espansione	Tank	Réservoir	Tank	Depósito	
	23	8C00 67963	2	Fascetta	Clamp	Collier	Schelle	Banda	
	24	8000 87071	1	Tubazione	Hose	Tuyau	Schlauch	Tube	

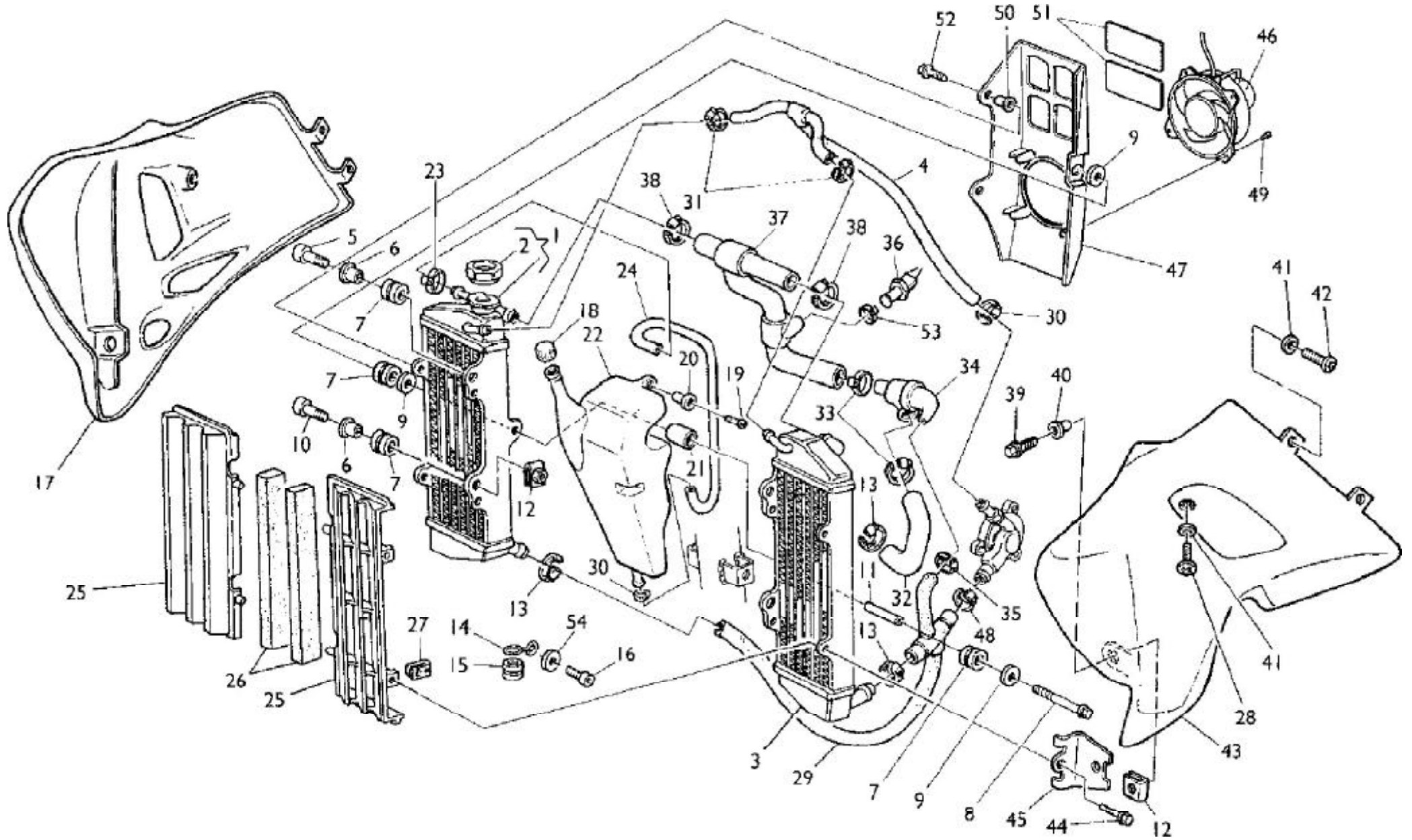

Note Notes Notas	Pos. No. N. Index Pos.	N. Cod. Code No. Nr. Code Code Nr N. Cod.	Q.tà Q.ty Q.te M.ge C.ad	DENOMINAZIONE	NAME	DESIGNATION	BESHREIBUNG	DENOMINACION	Validità Validity Validité Gültig Validez
	25	8000 A0872	2	Griglia	Grille	Grille	Gitter	Parilla	
	26	8000 87072	2	Antivibrante	Silent-block	Antivibration	Schwingungsdämpfer	Anti-vibrador	
	27	8000 60873	4	Dado a graffetta	Nut	Ecrou	Mutter	Tuerca	
	28	8000 62725	2	Vite	Screw	Vis	Schraube	Tornillo	
	29	8000 85313	1	Tubazione	Hose	Tuyau	Schlauch	Tubo	
	30	8000 67610	2	Fascetta	Clamp	Collier	Schelle	Banda	
	31	8000 34017	2	Fascetta	Clamp	Collier	Schelle	Banda	
	32	8000 85314	1	Tubo cilindro - termostato	Hose	Tuyau	Schlauch	Tubo	
	33	8000 50455	2	Fascetta	Clamp	Collier	Schelle	Banda	
	34	8A00 75984	1	Termostato	Thermo-switch	Thermostate	Thermostat	Termostato	
	35	8000 99475	1	Fascetta	Clamp	Collier	Schelle	Banda	
	36	8000 85374	1	Termointerruttore	Thermometer	Termomètre	Thermometer	Termometro	
SS	37	8A00 85312	1	Tubazione	Hose	Tuyau	Schlauch	Tubo	
TTE	37	8000 85312	1	Tubazione (&)	Hose (&)	Tuyau (&)	Schlauch (&)	Tubo (&)	
TT	37	8A00 85312	1	Tubazione (@)	Hose (@)	Tuyau (@)	Schlauch (@)	Tubo (@)	
	38	8B00 99475	2	Fascetta	Clamp	Collier	Schelle	Banda	
	39	8000 62729	2	Vite	Screw	Vis	Schraube	Tornillo	
	40	8000 76069	2	Boccola	Bush	Douille	Buchse	Casquillo	
	41	8000 45495	6	Rosetta	Washer	Rondelle	Scheibe	Arandela	
	42	8000 36467	4	Vite	Screw	Vis	Schraube	Tornillo	
	43	80D0 87062	1	Convogliatore Sx. (codice colore F)	Left side panel (color code F)	Flanc gauche (code couleur F)	Linke Flanke (Code Farbe F)	Lateral izquierdo (còdigo colòr F)	
	43	80G0 87062	1	Convogliatore Sx. (codice colore E)	Left side panel (color code E)	Flanc gauche (code couleur E)	Linke Flanke (Code Farbe E)	Lateral izquierdo (còdigo colòr E)	
	44	8000 62726	2	Vite	Screw	Vôs	Schraube	Tornillo	
	45	8000 87127	2	Piastrina	Plate	Plaque	Platte	Placa	
	46	8000 86104	1	Elettroventola	Fan	Ventilateur	Kühlungsflügel	Aventadÿr	
	47	8000 86747	1	Cappa	Grille	Grille	Gitter	Parilla	
	48	8000 22613	1	Fascetta	Clamp	Collier	Schelle	Banda	
	49	8000 36241	4	Vite	Screw	Vôs	Schraube	Tornillo	
	50	8000 45495	2	Bussola	Bushing	Douille	Buchse	Manguito	
	51	8000 86746	2	Membrana	Membrane	Membrane	Membrane	Membrana	
	52	8000 62727	2	Vite	Screw	Vôs	Schraube	Tornillo	

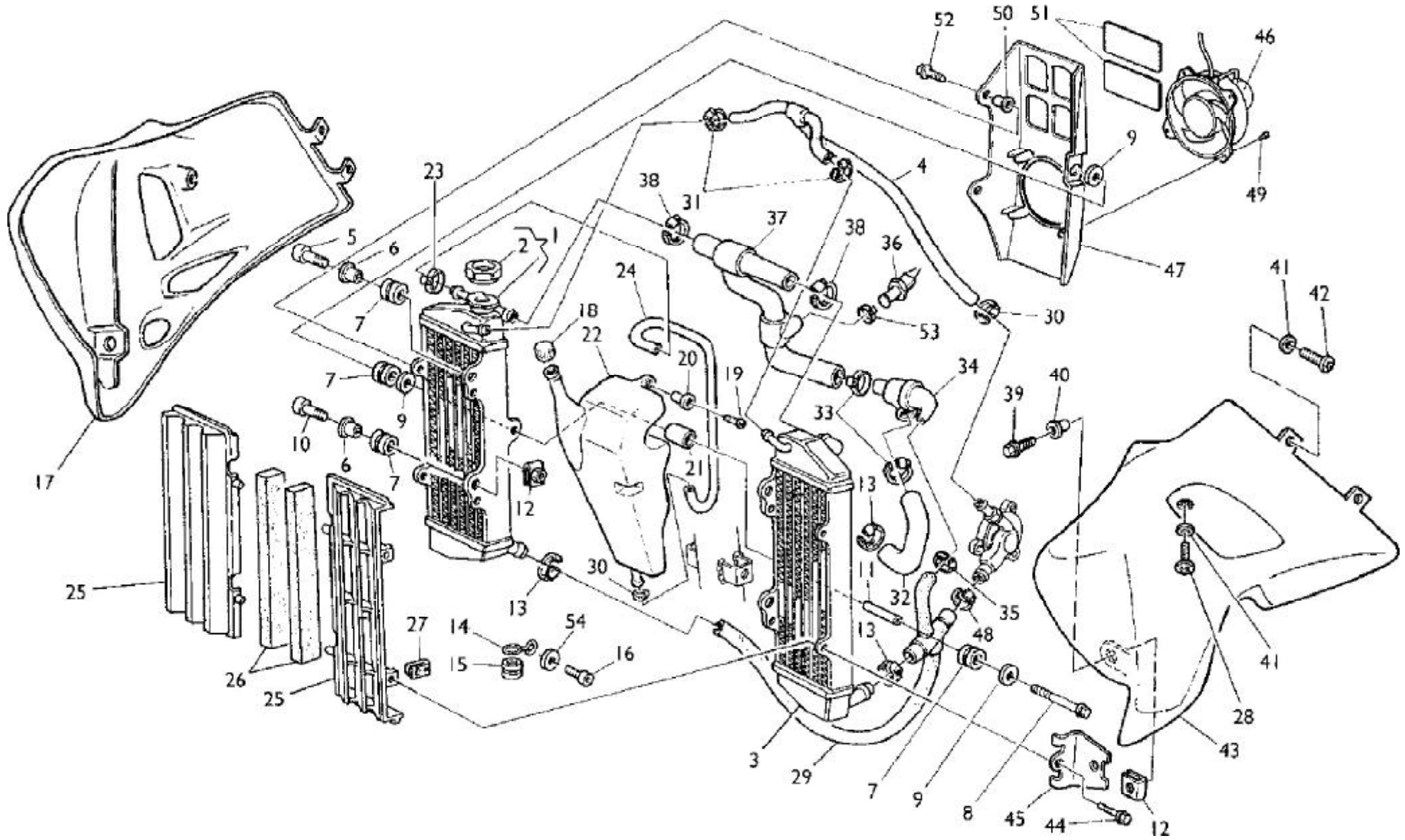

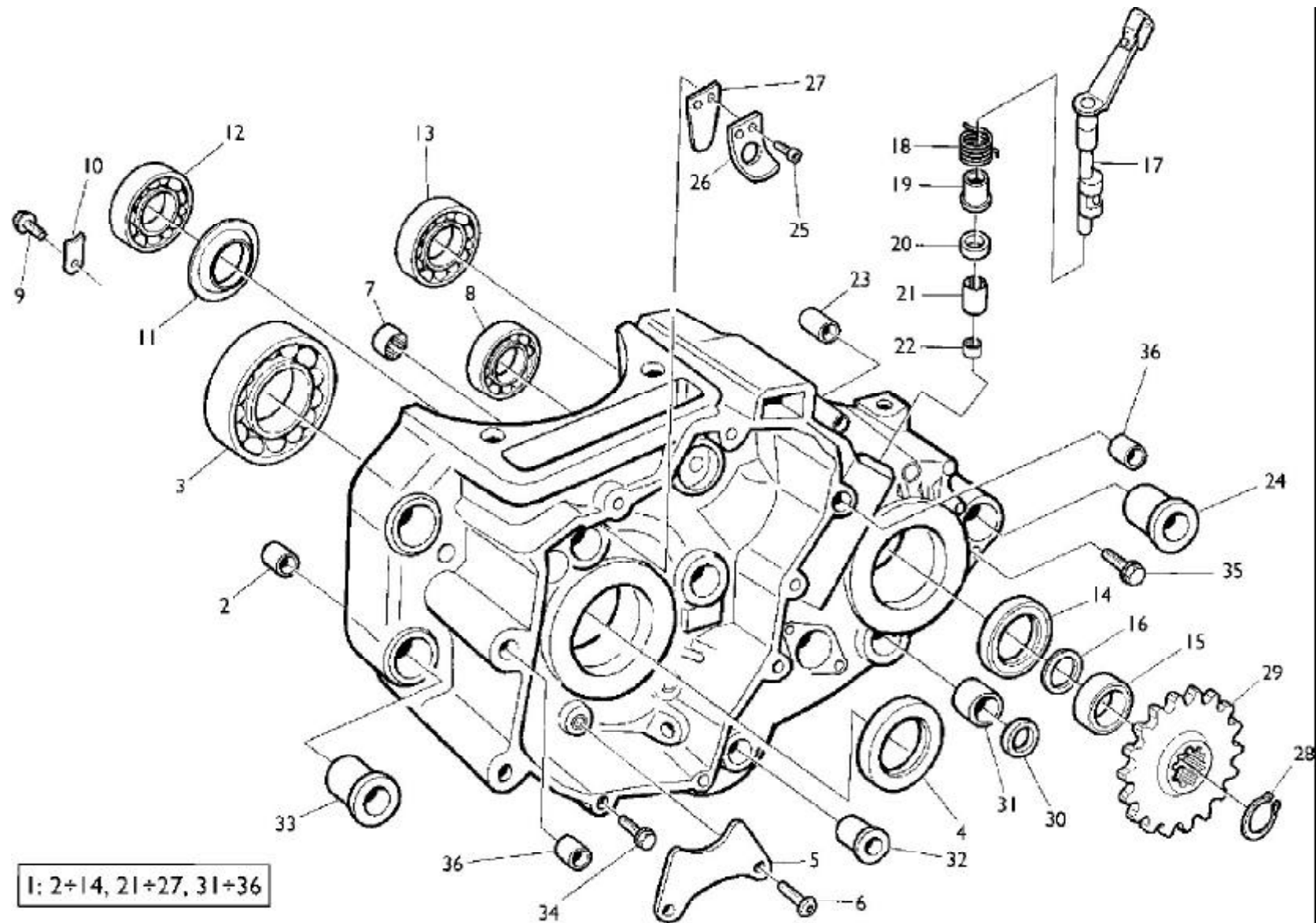

Note Notes Notas	Pos. No. Index Pos.	N. Cod. Code No. Nr. Code Code Nr N. Cod.	Q.tà Q.ty Q.te M.ge C.ad	DENOMINAZIONE	NAME	DESIGNATION	BESHREIBUNG	DENOMINACION	Validità Validity Validité Gültig Validez
	1	8000 81660	1	Assieme carters accoppiati	Crankcase assy	Carter compl.	Kurberlgehäuse kpl.	Carter completi	
	2	1610 77601	1	Bussola centraggio anteriore	Bushing	Douille	Buchse	Manguito	
	3	8000 85380	1	Cuscinetto a sfere (ø45xø85x19mm)	Bearing (ø45xø85x19mm)	Roulement (ø45xø85x19mm)	Lager (ø45xø85x19mm)	Cojinete (ø45xø85x19mm)	
	4	8000 85381	1	Anello di tenuta (ø45xø60x7mm)	Seal ring (ø45xø60x7mm)	Bague de retenue (ø45xø60x7mm)	Dichtring (ø45xø60x7mm)	Anillo de retención (ø45xø60x7mm)	
	5	8000 85383	1	Piastrina	Plate	Plaquette	Plättchen	Placa	
	6	8A00 67997	2	Vite	Screw	Vis	Schraube	Tornillo	
	7	8000 62200	1	Boccola a rullini (alb. cambio) (ø24xø30x7,5mm)	Rollenbush (gearbox shaft) (ø24xø30x7,5mm)	Douille rouleaux (arbre vitesse) (ø24xø30x7,5mm)	Rollerbuchse (Schaltungs- -welle) (ø24xø30x7,5mm)	Casquillo (eje cambio) (ø24xø30x7,5mm)	
	8	8000 19768	1	Cuscinetto radiale (alb. primario) (ø15xø42x13mm)	Bearing (main shaft) (ø15xø42x13mm)	Roulement (arbre primaire) (ø15xø42x13mm)	Lager (Hauptwelle) (ø15xø42x13mm)	Cojinete (eje principal) (ø15xø42x13mm)	
	9	8A00 66525	1	Vite	Screw	Vis	Schraube	Tornillo	
	10	8000 81663	1	Piastrina	Plate	Plaquette	Plättchen	Placa	
	11	8000 72966	1	Schermo di tenuta	Seal Ring	Bague de retenue	Dichtring	Anillo de retención	
	12	8000 72964	1	Cuscinetto a rulli (contralbero) (ø20xø47x14mm)	Bearing (counter-shaft) (ø20xø47x14mm)	Roulement (arbre de bal.) (ø20xø47x14mm)	Lager (Vorgelegewelle) (ø20xø47x14mm)	Cojinete (contra-eje) (ø20xø47x14mm)	
	13	8000 43789	1	Cuscinetto a rulli (alb. second.) (ø25xø52x15mm)	Bearing (secondary-shaft) (ø25xø52x15mm)	Roulement (arbre secondaire) (ø25xø52x15mm)	Lager (Sekundärwelle) (ø25xø52x15mm)	Cojinete (eje-secundario) (ø25xø52x15mm)	
	14	8000 59977	1	Anello di tenuta (ø32xø40x5mm)	Seal ring (ø32xø40x5mm)	Bague de retenue (ø32xø40x5mm)	Dichtring (ø32xø40x5mm)	Anillo de retención (ø32xø40x5mm)	
	15	8000 60464	1	Distanziale	Spacer	Entretoise	Distanzstück	Separador	
	16	8000 23110	1	Anello OR	O-Ring	Bague OR	O-Ring	Anillo OR	
	17	8000 81676	1	Albero comando frizione	Shaft assy	Arbre compl.	Kpl. welle	Eje comp.	
	18	8000 82047	1	Molla	Spring	Ressort	Feder	Resorte	
	19	8B00 55532	1	Bussola	Bushing	Douille	Buchse	Manguito	
	20	8000 48856	1	Anello di tenuta (ø13xø20x4mm)	Seal ring (ø13xø20x4mm)	Bague de retenue (ø13xø20x4mm)	Dichtring (ø13xø20x4mm)	Anillo de retención (ø13xø20x4mm)	
	21	8000 49016	1	Boccola a rullini (ø13xø19x12mm)	Rollenbush (ø13xø19x12mm)	Douille rouleaux (ø13xø19x12mm)	Rollerbuchse (ø13xø19x12mm)	Casquillo (ø13xø19x12mm)	
	22	8000 42244	1	Boccola a rullini (ø7xø11x9mm)	Rollenbush (ø7xø11x9mm)	Douille rouleaux (ø7xø11x9mm)	Rollerbuchse (ø7xø11x9mm)	Casquillo (ø7xø11x9mm)	
	23	1614 59002	1	Bussola	Bushing	Douille	Buchse	Manguito	

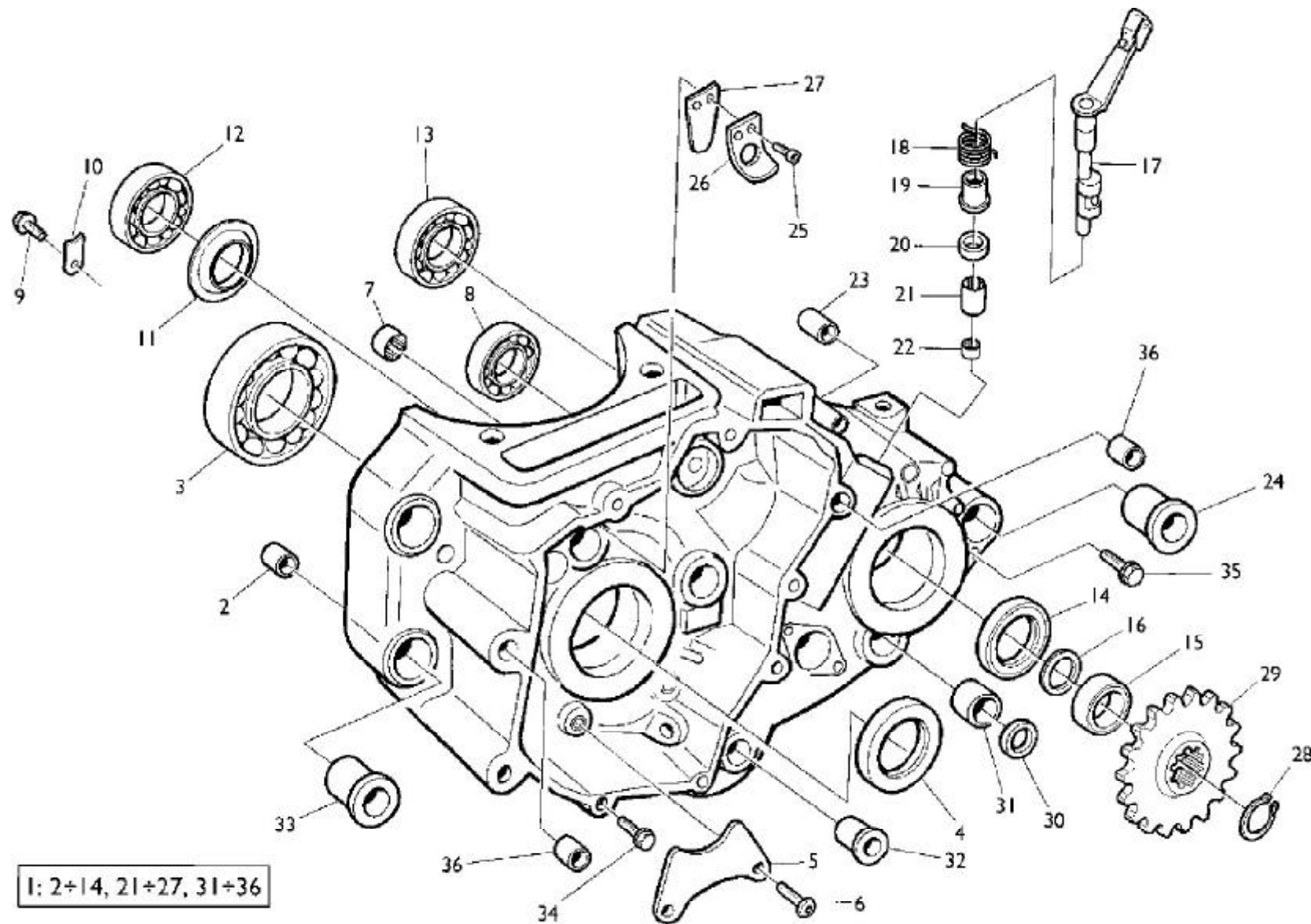

Note Notes Notes Marke Notas	Pos. No. N. Index Pos.	N. Cod. Code No. Nr. Code Code Nr N. Cod.	Q.tà Q.ty Q.te M.ge C.ad	DENOMINAZIONE	NAME	DESIGNATION	BESHREIBUNG	DENOMINACION	Validità Validity Validité Gültig Validez
	24	8000 71154	1	Bussola	Bushing	Douille	Buchse	Manguito	
	25	60N1 02866	2	Vite	Screw	Vis	Schraube	Tornillo	
	26	1615 10501	1	Ferma lamella	Retainer	Arret	Klammer	Abrazadera de sujeción	
	27	1615 34801	1	Valvola a lamella	Reed valve	Soupape lamellaire	Ventil Lamellar	Válvula laminar	
	28	66N0 21211	1	Anello elastico	Ring	Anneau ressort	Sprengring	Anillo elastico	
R	29	8000 63829	1	Pignone (Z = 14)	Pinion (Z = 14)	Pignon (Z = 14)	Ritzel (Z = 14)	Piñon (Z = 14)	
TT	29	8000 63830	1	Pignone (Z = 15)	Pinion (Z = 15)	Pignon (Z = 15)	Ritzel (Z = 15)	Piñon (Z = 15)	
SS	29	8000 63831	1	Pignone (Z = 16)	Pinion (Z = 16)	Pignon (Z = 16)	Ritzel (Z = 16)	Piñon (Z = 16)	
	30	8000 34451	1	Anello di tenuta (ø12xø19x5mm)	Seal Ring (ø12xø19x5mm)	Bague de retenue (ø12xø19x5mm)	Dichtring (ø12xø19x5mm)	Anillo de retención (ø12xø19x5mm)	
	31	8A00 65847	1	Boccola	Bush	Douille	Buchse	Casquillo	
	32	1610 77701	1	Bussola	Bushing	Douille	Buchse	Casquillo	
	33	1610 77702	2	Bussola	Bushing	Douille	Buchse	Casquillo	
	34	8B00 67545	9	Vite (L = M6x55 mm)	Screw (L = M6x55 mm)	Vis (L = M6x55 mm)	Schraube (L = M6x55 mm)	Tornillo (L = M6x55 mm)	
	35	8C00 67545	2	Vite (L = M6x65 mm)	Screw (L = M6x65 mm)	Vis (L = M6x65 mm)	Schraube (L = M6x65 mm)	Tornillo (L = M6x65 mm)	
	36	8000 07719	2	Bussola	Bushing	Douille	Buchse	Casquillo	

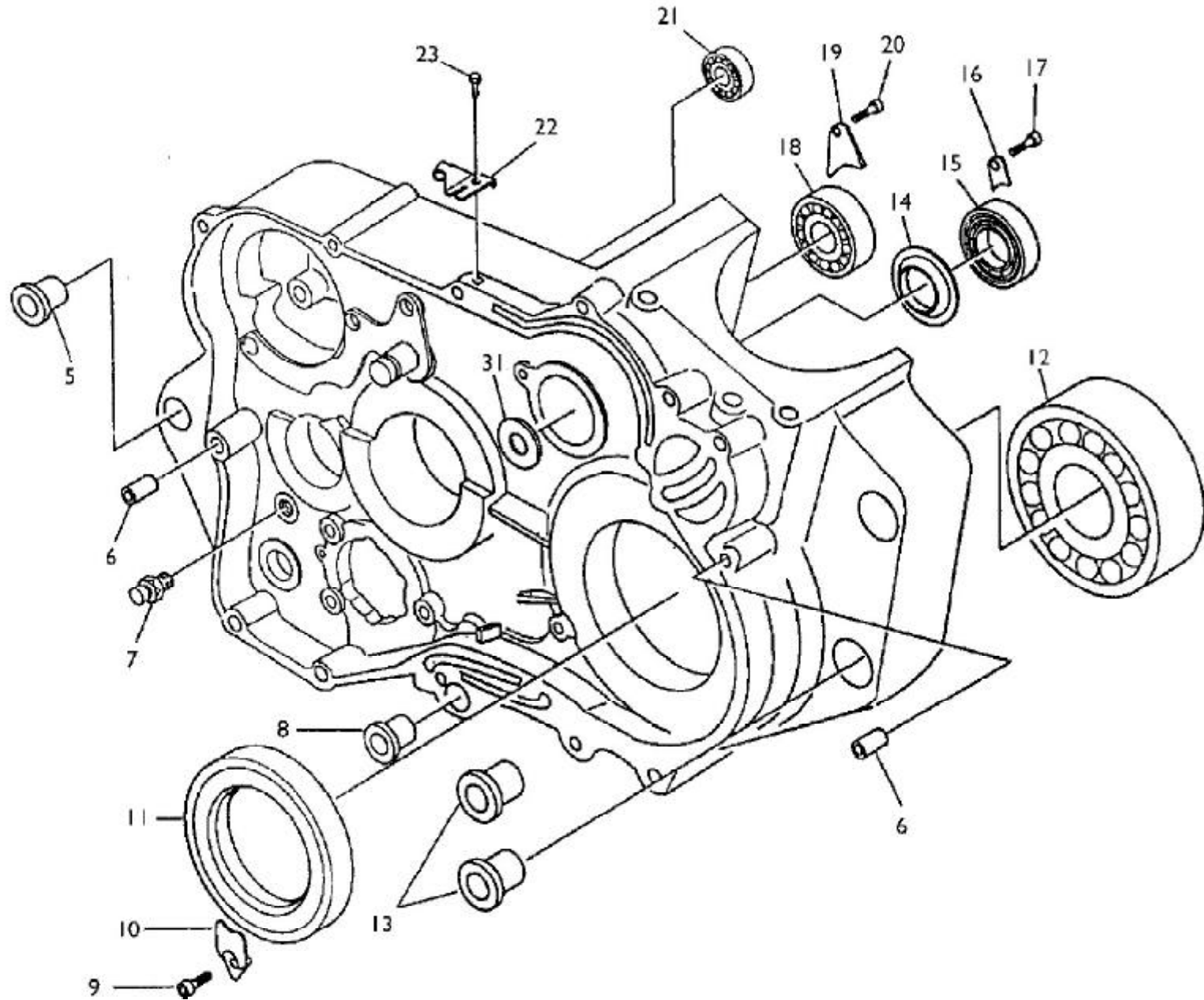

1: 5÷21

Note Notes Notas	Pos. No. N. Index Pos.	N. Cod. Code No. Nr. Code Code Nr N. Cod.	Q.tà Q.ty Q.te M.ge C.ad	DENOMINAZIONE	NAME	DESIGNATION	BESHREIBUNG	DENOMINACION	Validità Validity Validité Gültig Validez
	1	8000 81660	1	Assieme carters accoppiati	Crankcases assy	Carters compl.	Kuberlgehausen kpl.	Carter motor compl.	
	5	8000 71154	1	Bussola flangiata	Bushing	Douille	Buchse	Manguito	
	6	8000 07719	2	Bussola centraggio	Bushing	Douille	Buchse	Manguito	
	7	8A00 66953	1	Perno di fermo selettore	Pin	Pivot	Bolzen	Perno	
	8	1610 77701	1	Bussola flangiata	Bushing	Douille	Buchse	Manguito	
	9	8000 62725	1	Vite	Screw	Vis	Schraube	Tornillo	
	10	8000 85382	1	Piastrina ritegno paraolio	Plate	Plaquette	Plättchen	Placa	
	11	8000 85381	1	Anello di tenuta (ø45xø60x7mm)	Seal ring (ø45xø60x7mm)	Bague de retenue (ø45xø60x7mm)	Dichtring (ø45xø60x7mm)	Anillo de retención (ø45xø60x7mm)	
	12	8000 85380	1	Cuscinetto a sfere (ø45xø85x19mm)	Bearing (ø45xø85x19mm)	Roulement (ø45xø85x19mm)	Kugellager (ø45xø85x19mm)	Cojinete (ø45xø85x19mm)	
	13	1610 77702	2	Bussola flangiata	Bushing	Douille	Buchse	Manguito	
	14	8B00 72966	1	Schermo tenuta	Retainer	Arret	Klammer	Abrazadera de sujeción	
	15	8000 15659	1	Cuscinetto radiale stagno (contralbero) (ø20xø47x14mm)	Bearing (counter-shaft) (ø20xø47x14mm)	Roulement (arbre de bal.) (ø20xø47x14mm)	Kugellager (Vorgelegewelle) (ø20xø47x14mm)	Cojinete (contra-eje) (ø20xø47x14mm)	
	16	8000 81663	1	Piastrina ritegno	Retainer	Arret	Klammer	Abrazadera de sujeción	
	17	8A00 66525	1	Vite	Screw	Vis	Schraube	Tornillo	
	18	8A00 59975	1	Cuscinetto a sfere (ø25xø52x15mm)	Bearing (ø25xø52x15mm)	Roulement (ø25xø52x15mm)	Kugellager (ø25xø52x15mm)	Cojinete (ø25xø52x15mm)	
	19	8000 51746	1	Piastrina ritegno	Plate	Plaque	Platte	Placa	
	20	8000 42643	1	Vite	Screw	Vis	Schraube	Tornillo	
	21	8000 72962	1	Cuscinetto a sfere (ø17xø47x14mm)	Bearing (secondary-shaft) (ø17xø47x14mm)	Roulement (arbre secondaire) (ø17xø47x14mm)	Kugellager (Sekundärwelle) (ø17xø47x14mm)	Cojinete (eje-secundario) (ø17xø47x14mm)	
	22	8000 85391	1	Piastrina ritegno cavo frizione	Plate	Plaque	Platte	Placa	
	23	8000 62727	1	Vite per piastrina	Screw	Vis	Schraube	Tornillo	

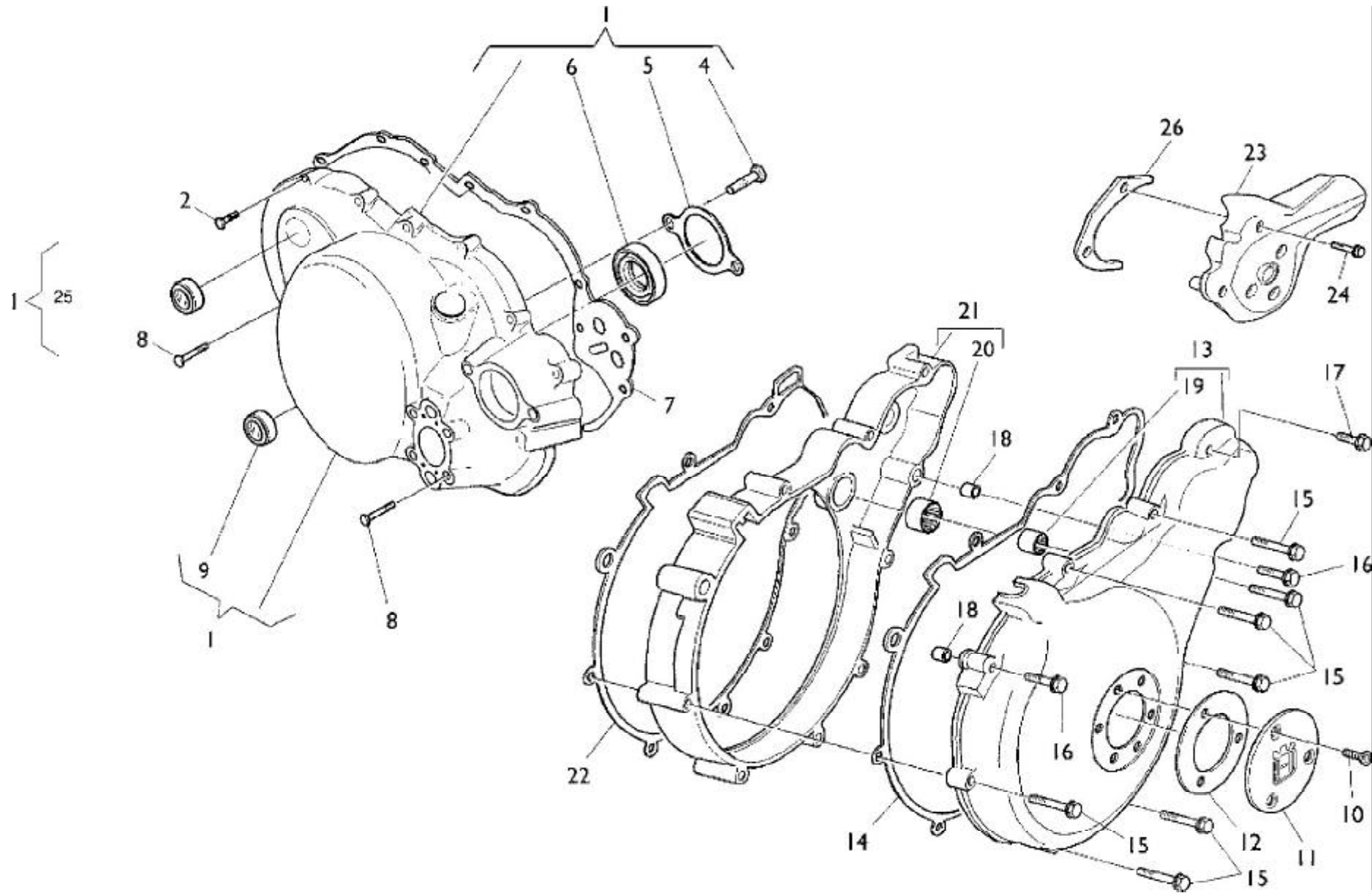

Note Notes Notas	Pos. No. N. Index Pos.	N. Cod. Code No. Nr. Code Code Nr N. Cod.	Q.tà Q.ty Q.te M.ge C.ad	DENOMINAZIONE	NAME	DESIGNATION	BESHREIBUNG	DENOMINACION	Validità Validity Validité Gültig Validez
	1	8000 92057	1	Coperchio destro completo	H. Cover assy	Couvercle compl. D.	Deckel kpl., R.	Tapa derech. compl.	
	2	8000 62730	11	Vite (M6x30 mm)	Screw (M6x30 mm)	Vis (M6x30 mm)	Schraube (M6x30 mm)	Schraube (M6x30 mm)	
	4	8000 49608	2	Vite	Screw	Vis	Schraube	Schraube	
	5	8000 A1374	1	Flangia	Retainer	Arret	Klammer	Abrazadera de sujeción	
	6	8000 62209	1	Anello di tenuta ($\varnothing 17 \times \varnothing 28 \times 7 \text{mm}$)	Seal Ring ($\varnothing 17 \times \varnothing 28 \times 7 \text{mm}$)	Bague de retenue ($\varnothing 17 \times \varnothing 28 \times 7 \text{mm}$)	Dichtring ($\varnothing 17 \times \varnothing 28 \times 7 \text{mm}$)	Anillo de retención ($\varnothing 17 \times \varnothing 28 \times 7 \text{mm}$)	
	7	8000 A1366	1	Guarnizione	Gasket	Garniture	Dichtung	Junta	
	8	8E00 67545	2	Vite (M6x40 mm)	Screw (M6x40 mm)	Vis (M6x40 mm)	Schraube (M6x40 mm)	Schraube (M6x40 mm)	
	9	8000 86048	1	Spia per livello olio	Oil inspection cap	Bouchon controle huile	Oelstandkontrolle	Mirilla nivel aceite	
	10	8000 28327	3	Vite	Screw	Vis	Schraube	Tornillo	
	11	80A0 84820	1	Coperchietto controllo fase	Cover	Couvercle	Deckel	Tapa	
	12	8000 A1369	1	Guarnizione	Gasket	Garniture	Dichtung	Junta	
	13	8000 86245	1	Ass. coperchio accensione	Cover	Couvercle	Deckel	Tapa	
	14	8000 A1368	1	Guarnizione	Gasket	Garniture	Dichtung	Junta	
	15	8B00 67545	7	Vite (M6x55 mm)	Screw (M6x55 mm)	Vis (M6x55 mm)	Schraube (M6x55 mm)	Tornillo (M6x55 mm)	
	16	8C00 67545	2	Vite (M6x65 mm)	Screw (M6x65 mm)	Vis (M6x65 mm)	Schraube (M6x65 mm)	Tornillo (M6x65 mm)	
	17	8000 62730	1	Vite (M6x30 mm)	Screw (M6x30 mm)	Vis (M6x30 mm)	Schraube (M6x30 mm)	Tornillo (M6x30 mm)	
	18	8000 07719	2	Bussola	Bushing	Douille	Buchse	Manguito	
	19	8000 86243	1	Boccola a rullini ($\varnothing 10 \times \varnothing 14 \times 15 \text{mm}$)	Rollenbush ($\varnothing 10 \times \varnothing 14 \times 15 \text{mm}$)	Douille rouleaux ($\varnothing 10 \times \varnothing 14 \times 15 \text{mm}$)	Rollerbuchse ($\varnothing 10 \times \varnothing 14 \times 15 \text{mm}$)	Casquillo ($\varnothing 10 \times \varnothing 14 \times 15 \text{mm}$)	
	20	8000 33422	1	Boccola a rullini ($\varnothing 14 \times \varnothing 20 \times 12 \text{mm}$)	Rollenbush ($\varnothing 14 \times \varnothing 20 \times 12 \text{mm}$)	Douille rouleaux ($\varnothing 14 \times \varnothing 20 \times 12 \text{mm}$)	Rollerbuchse ($\varnothing 14 \times \varnothing 20 \times 12 \text{mm}$)	Casquillo ($\varnothing 14 \times \varnothing 20 \times 12 \text{mm}$)	
	21	8000 86246	1	Ass. supporto motorino avviam.	Start motor holder assy	Support	Helterung	Soporte	
	22	8000 A1367	1	Guarnizione	Gasket	Garniture	Dichtung	Junta	
	23	8000 81673	1	Coperchio pignone catena	Cover	Couvercle	Deckel	Tapa	
	24	8B00 67545	2	Vite	Screw	Vis	Schraube	Tornillo	
	25	8000 35728	1	Tappo	Plug	Bouchon	Verschluss	Tapòn	
TT	26	8000 81674	1	Piastra guidacatena	Plate	Plaquette	Platte	Placa	

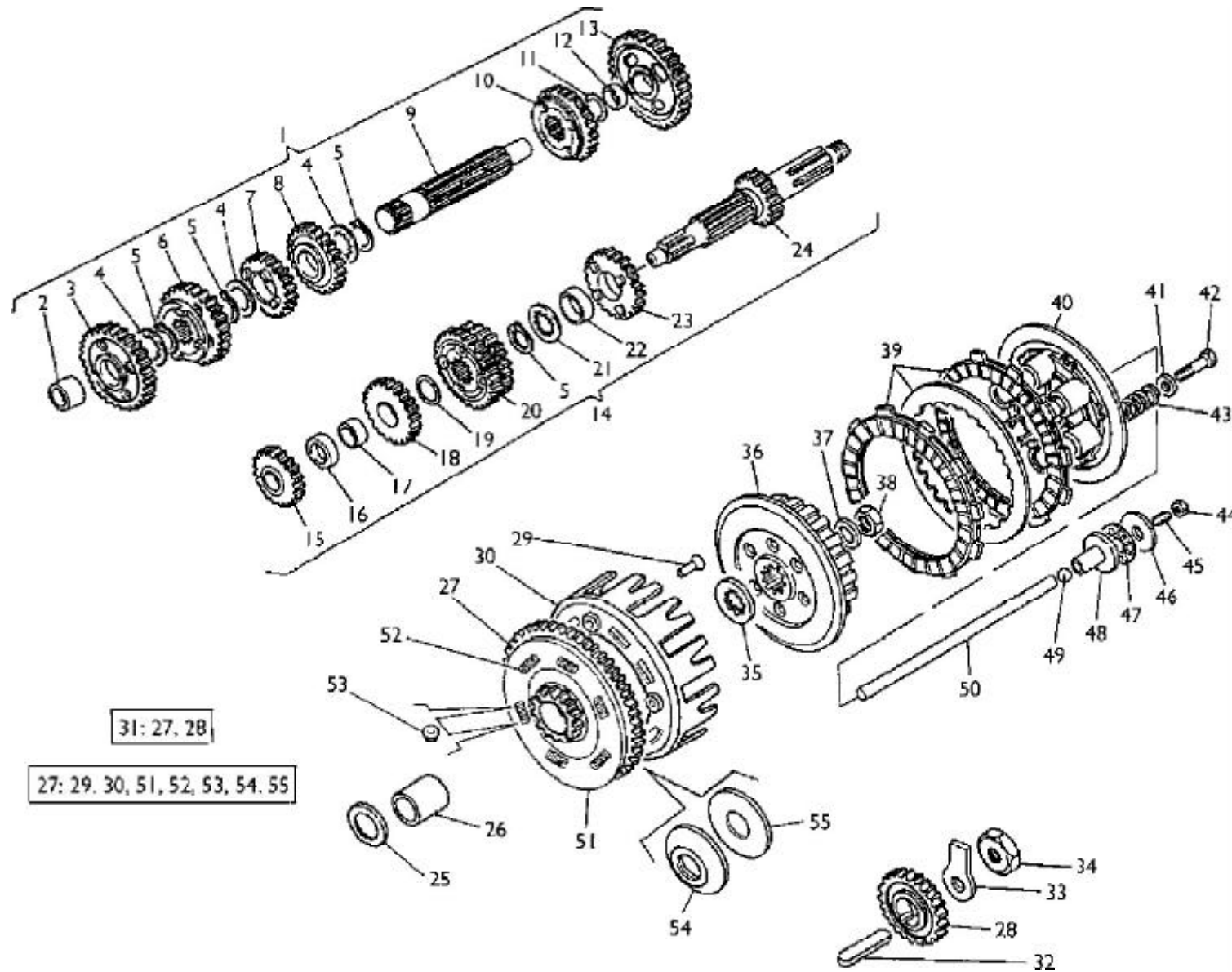

31: 27, 28

27: 29, 30, 51, 52, 53, 54, 55

Note Notes Notas	Pos. No. Index Pos.	N. Cod. Code No. Nr. Code Code Nr N. Cod.	Q.tà Q.ty Q.te M.ge C.ad	DENOMINAZIONE	NAME	DESIGNATION	BESHREIBUNG	DENOMINACION	Validità Validity Validité Gültig Validez
	1	8000 79689	1	Albero secondario completo	Secondary-shaft compl.	Arbre secondaire compl.	Secundärwelle kpl.	Eje secundario completo	
	2	8000 63822	1	Bussola	Bushing	Douille	Buchse	Manguito	
	3	8000 74864	1	Ingranaggio 2° A.S. (Z = 29) (Z = 29)	S. s. 2nd gear (Z = 29) (Z = 29)	Engrenage 2ème v. A.S. (Z=29)	Zah. f. 2. Geschw. S. W. (Z=29)	Engrenaje 2° vel. Eje S. (Z=29)	
	4	1611 71701	3	Rosetta di rasamento	Thrust washer	Rondelle de butée	Scheibe	Arandela	
	5	66N0 21211	4	Anello di fermo	Stop ring	Bague d'arrêt	Haltering	Anillo de retención	
	6	8000 79690	1	Ingranaggio 3° A.S. (Z = 27)	S. s. 3rd gear (Z = 27)	Engrenage 3ème vitesse A.S. (Z = 27)	Zah. f. 3. Geschw. S. W. (Z = 27)	Engranaje 3° velocidad Eje S. (Z = 27)	
	7	8000 79691	1	Ingranaggio 6° A.S. (Z = 20)	S. s. 6th gear (Z = 20)	Engrenage 6ème vitesse A.S. (Z = 20)	Zah. f. 6. Geschw. S. W. (Z = 20)	Engranaje 6° velocidad Eje S. (Z = 20)	
	8	8000 79692	1	Ingranaggio 5° A.S. (Z = 22)	S. s. 5th gear (Z = 22)	Engrenage 5ème vitesse A.S. (Z = 22)	Zah. f. 5. Geschw. S. W. (Z = 22)	Engranaje 5° velocidad Eje S. (Z = 22)	
	9	8A00 60463	1	Albero secondario	Secondary-shaft	Arbre secondaire	Secundärwelle	Eje secundario	
	10	8000 79693	1	Ingranaggio 4° A.S. (Z = 24)	S. s. 4th gear (Z = 24)	Engrenage 4ème vitesse A.S. (Z = 24)	Zah. f. 4. Geschw. S. W. (Z = 24)	Engranaje 4° velocidad Eje S. (Z = 24)	
	11	1513 71401	1	Rosetta di rasamento	Thrust washer	Rondelle de butée	Scheibe	Arandela	
	12	1612 41501	1	Bussola	Bushing	Douille	Buchse	Manguito	
	13	8000 74862	1	Ingranaggio 1° A.S. (Z = 34)	S. s. 1st gear (Z = 34)	Engrenage 1ère vitesse A.S. (Z = 34)	Zah. f. 1. Geschw. S. W. (Z = 34)	Engranaje 1° velocidad Eje S. (Z = 34)	
&	14	8000 79685	1	Albero primario completo (Ø 23 mm)	Main shaft (Ø 23 mm)	Arbre primaire (Ø 23 mm)	Hauptwelle (Ø 23 mm)	Eje principal completo (Ø 23 mm)	F.m.
@	14	8A00 79685	1	Albero primario completo (Ø 25 mm)	Main shaft (Ø 25 mm)	Arbre primaire (Ø 25 mm)	Hauptwelle (Ø 25 mm)	Eje principal completo (Ø 25 mm)	D.m.
	15	8000 74863	1	Ingranaggio 2° A.P. (Z = 16)	M. s. 2nd gear (Z = 16)	Engrenage 2ème vitesse A.P. (Z = 16)	Zahn. f. 2. Geschw. A. W. (Z = 16)	Engrenaje 2° velocidad Eje P. (Z = 16)	
	16	1612 48101	1	Distanziale	Spacer	Entretoise	Distanzstück	Separador	
	17	1612 48001	1	Bussola	Bushing	Douille	Buchse	Manguito	
	18	8000 79688	1	Ingranaggio 3° A.P. (Z = 20)	M. s. 3rd gear (Z = 20)	Engrenage 3ème vitesse A.P. (Z = 20)	Zahn. f. 3. Geschw. A. W. (Z = 20)	Engrenaje 3° velocidad Eje P. (Z = 20)	
	19	1612 84201	1	Rosetta	Washer	Rondelle	Scheibe	Arandela	
	20	8000 79687	1	Ingran. 5° e 6° A.P. (Z = 24 - 26)	Gear 5th - 6th speed (Z = 24 - 26)	Engrenage 5ème 6ème (Z = 24 - 26)	Zahnrad 5. - 6. Gang (Z = 24 - 26)	Engrenaje 5° - 6° velocidad (Z = 24 - 26)	
	21	8H00 36022	1	Rosetta di rasamento	Washer	Rondelle de butée	Ausgleichscheibe	Arandela de Tope	

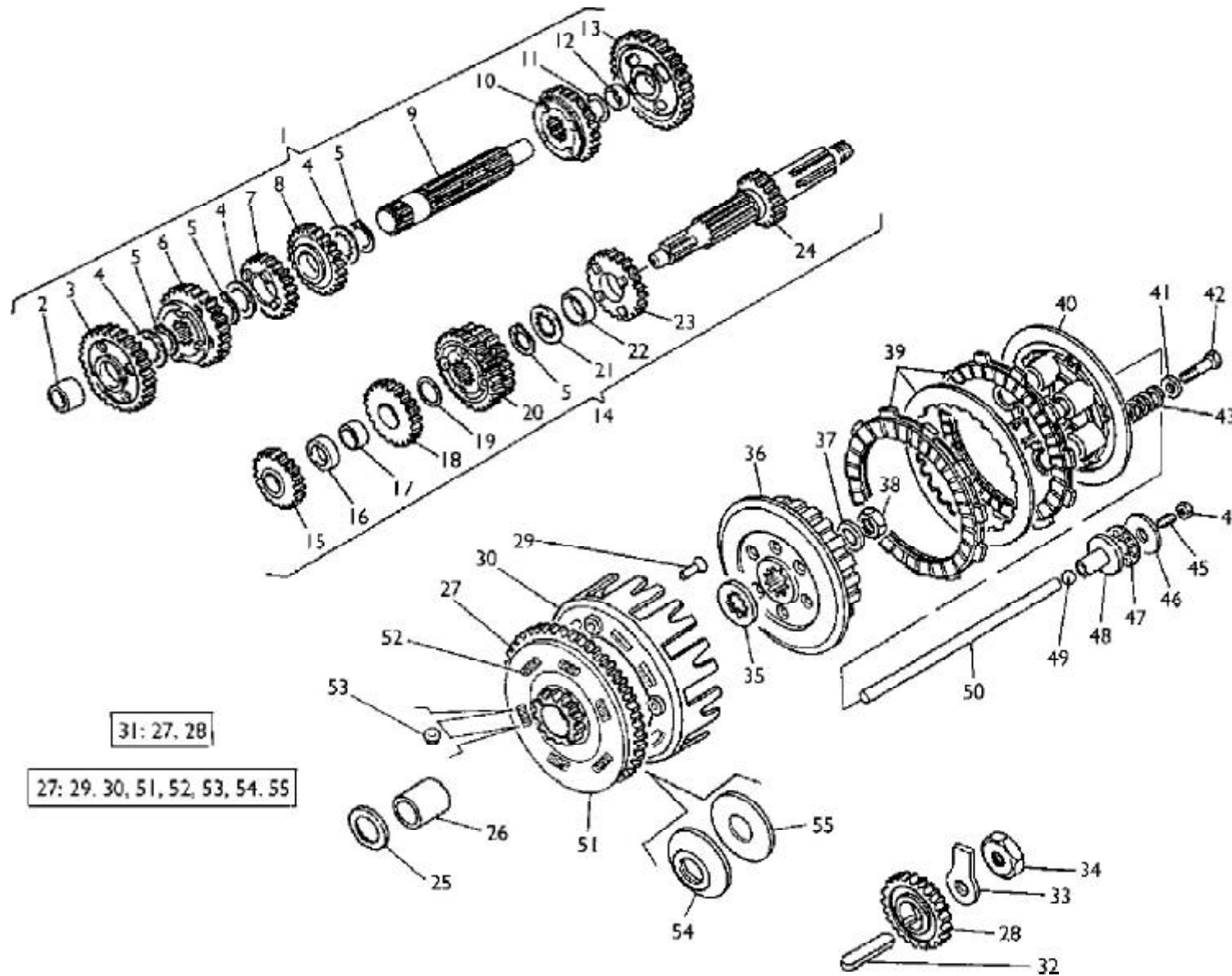

Note Notes Notas	Pos. No. N. Index Pos.	N. Cod. Code No. Nr. Code Code Nr N. Cod.	Q.tà Q.ty Q.te M.ge C.ad	DENOMINAZIONE	NAME	DESIGNATION	BESHREIBUNG	DENOMINACION	Validità Validity Validité Gültig Validez
	22	8000 63821	1	Bussola	Bushing	Douille	Buchse	Manguito	
	23	8000 79686	1	Ingranaggio 4° A.P. (Z = 22)	M. s. 4th gear (Z = 22)	Engrenage 4ème vitesse A.P. (Z = 22)	Zahnf. f. 4. Geschw. A. W. (Z = 22)	Engrenaje 4° velocidad Eje P. (Z = 22)	
&	24	8000 74861	1	Albero primario (Z = 13) (Ø 23 mm)	Main shaft (Z = 13) (Ø 23 mm)	Arbre primaire (Z = 13) (Ø 23 mm)	Hauptwelle (Z = 13) (Ø 23 mm)	Eje primario (Z = 13) (Ø 23 mm)	F.m.
@	24	8A00 74861	1	Albero primario (Z = 13) (Ø 25 mm)	Main shaft (Z = 13) (Ø 25 mm)	Arbre primaire (Z = 13) (Ø 25 mm)	Hauptwelle (Z = 13) (Ø 25 mm)	Eje primario (Z = 13) (Ø 25 mm)	D.m.
	25	8C00 16930	1	Rosetta di spallamento	Washer	Rondelle	Scheibe	Arandela	
&	26	8000 72943	1	Bussola (Ø 26 mmxØ 23 mm)	Bushing (Ø 26 mmxØ 23 mm)	Douille (Ø 26 mmxØ 23 mm)	Buchse (Ø 26 mmxØ 23 mm)	Manguito (Ø26mmx Ø23mm)	F.m.
@	26	1615 38802	1	Bussola (Ø 28 mmxØ 25 mm)	Bushing (Ø 28 mmxØ 25 mm)	Douille (Ø 28 mmxØ 25 mm)	Buchse (Ø 28 mmxØ 25 mm)	Manguito (Ø28mmx Ø25mm)	D.m.
&	27	8000 85025	1	Ass. ingr. Condotta (Ø 26 mm) con campana (Z = 16 - 75)	Driving gear assy (Ø 26 mm) (Z = 16 - 75)	Engren. conducteur (Ø 26mm) complet (Z = 16 - 75)	Zahnrad kpl. (Ø 26 mm) (Z = 16 - 75)	Engrenaje conductor compl. (Ø 26 mm) (Z = 16 - 75)	F.m.
@	27	8000 A0372	1	Ass. ingr. Condotta (Ø 28 mm) con campana (Z = 16 - 75)	Driving gear assy (Ø 28 mm) (Z = 16 - 75)	Engren. conducteur (Ø 28mm) complet (Z = 16 - 75)	Zahnrad kpl. (Ø 28 mm) (Z = 16 - 75)	Engrenaje conductor compl. (Ø 28 mm) (Z = 16 - 75)	D.m.
&	28	8000 79309	1	Ingranaggio conduttore (Z = 32)	Driving gear (Z = 32)	Engrenage conducteur (Z = 32)	Zahnrad (Z = 32)	Engrenaje conductor (Z = 32)	F.m.
@	28	8000 97935	1	Ingranaggio conduttore (Z = 32)	Driving gear (Z = 32)	Engrenage conducteur (Z = 32)	Zahnrad (Z = 32)	Engrenaje conductor (Z = 32)	D.m.
	29	8000 36848	3	Ribattino	Rivet	Rivet	Niet	Remache	
	30	8000 84424	1	Campana frizione	Clutch housing	Cage embrayage	Kupplungskorb	Campana embrague	
&	31	8000 85024	1	Coppia ingran. trasm. primaria	Set of matched primary	Engrenages trans. prim.	Stimraderpaar	Copla engr. trans. primaria	F.m.
@	31	8000 A0371	1	Coppia ingran. trasm. primaria	Set of matched primary	Engrenages trans. prim.	Stimraderpaar	Copla engr. trans. primaria	D.m.
	32	8000 22426	1	Chiavetta	Woodruff key	Clé woodruff	Federkeil	Lengüeta	
	33	8000 86007	1	Rosetta di sicurezza	Washer	Rondelle	Scheibe	Arandela	
	34	8000 86006	1	Dado	Nut	Ecrou	Mutter	Tuerca	
	35	8000 38350	1	Rosetta	Washer	Rondelle	Scheibe	Arandela	
	36	8000 85390	1	Mozzo frizione	Hub	Moyeau	Radnabe	Cubo	
	37	8000 36857	1	Rosetta di sicurezza	Washer	Rondelle	Scheibe	Arandela	
	38	8000 36856	1	Dado	Nut	Ecrou	Mutter	Tuerca	
H	39	8B00 61095	8	Disco conduttore	Driving disc	Disque conducteur	Belagscheibe	Disco conductor	
H	39	8000 51148	7	Disco condotto	Driven disc	Disque conduit	Stahlscheibe	Disco conducido	
	40	8000 48138	1	Piastra spingidischi	Plate	Plaque	Platte	Placa	
	41	8000 21535	6	Rosetta	Washer	Rondelle	Scheibe	Arandela	

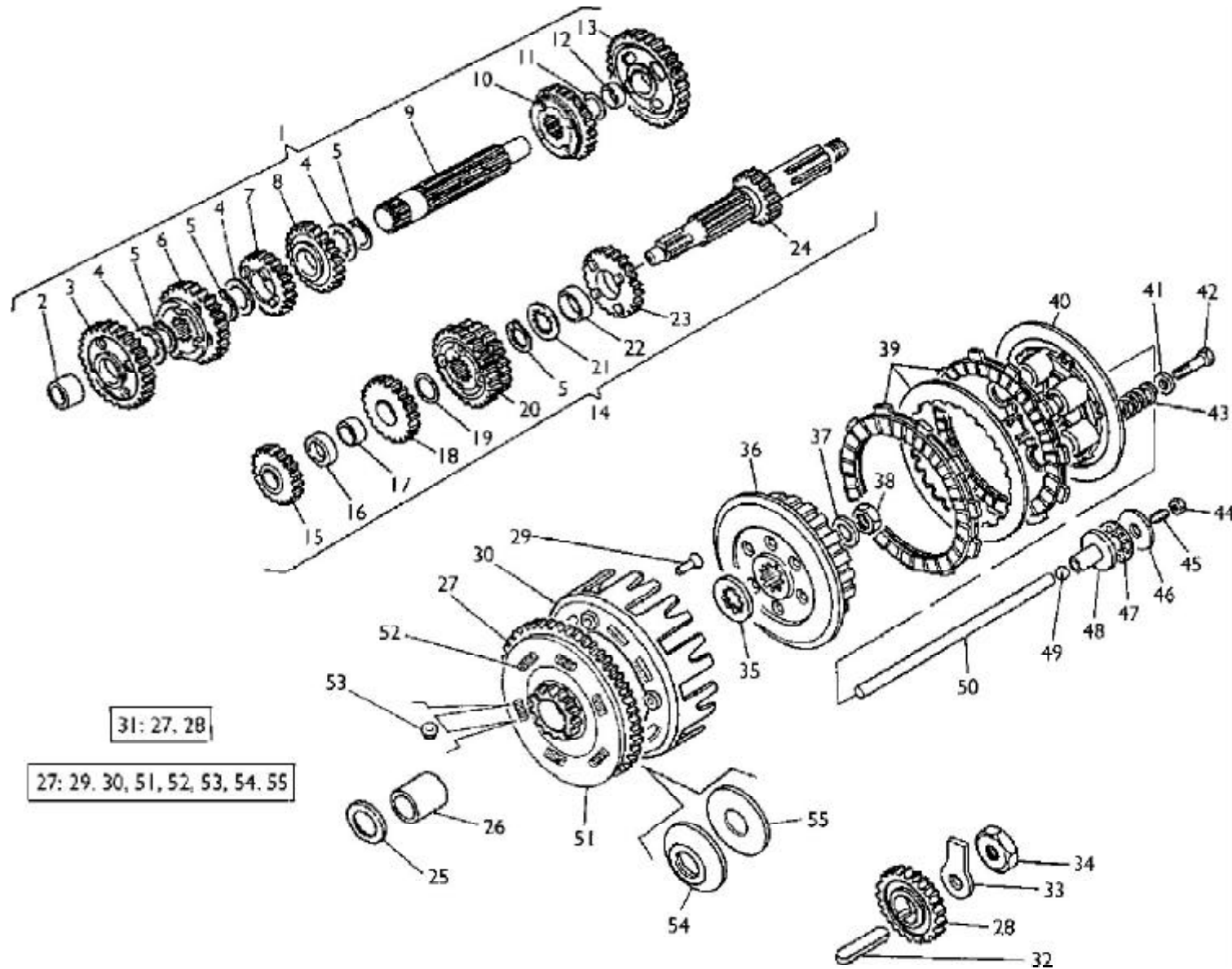

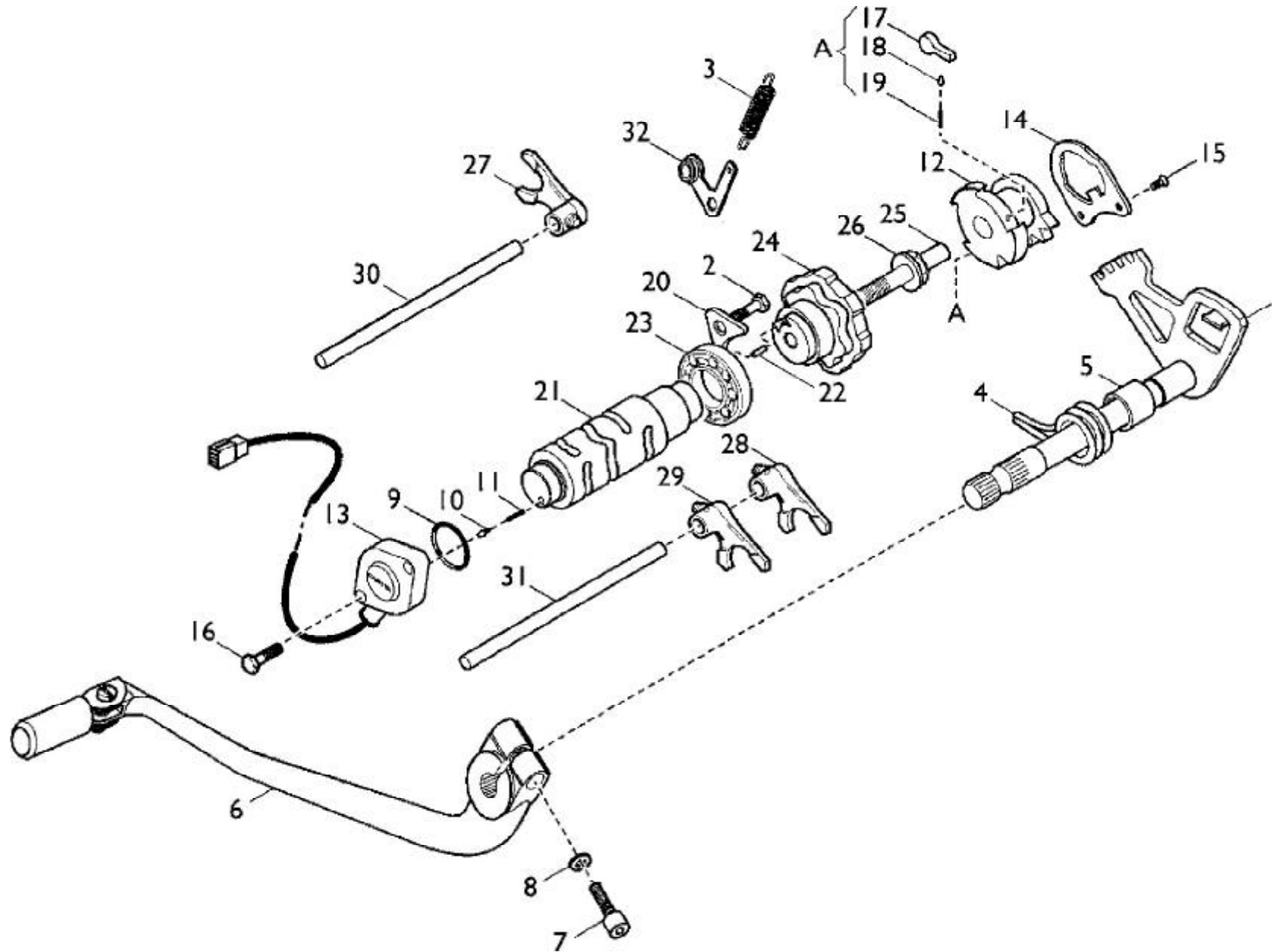

Note Notes Notas	Pos. No. N. Index Pos.	N. Cod. Code No. Nr. Code Code Nr N. Cod.	Q.tà Q.ty Q.te M.ge C.ad	DENOMINAZIONE	NAME	DESIGNATION	BESHREIBUNG	DENOMINACION	Validità Validity Validité Gültig Validez
	1	8000 75302	1	Albero com. selettore	Gearbox pedal shaft assy	Arbre péd. change vit. compl.	Pedal Umsteuerungswelle kpl.	Eje pedal cambio compl.	
	2	8B00 54139	1	Vite	Screw	Vis	Schraube	Tornillo	
	3	8000 88159	1	Molla	Spring	Ressort	Feder	Resorte	
	4	8000 46225	1	Molla	Spring	Ressort	Feder	Resorte	
	5	8A00 31503	1	Bussola	Bushing	Douille	Buchse	Manguito	
	6	8000 81681	1	Leva comando cambio	Gearchange lever assy	Levier comm. vitesse compl.	Schalthebel kpl.	Palanca del cambio compl.	
	7	60NA 01082	1	Vite	Screw	Vis	Schraube	Tornillo	
	8	62NA 15767	1	Rosetta elastica	Washer	Rondelle	Scheibe	Arandela	
	9	8A00 42700	1	Anello OR	O-Ring	Bague OR	O-Ring	Anillo OR	
	10	8000 42676	1	Puntale per segnalatore marce	Push rod	Embout	Stösselschaft	Puntal	
	11	8000 42677	1	Molla	Spring	Ressort	Feder	Resorte	
	12	8000 75291	1	Rocchetto selettore dentato	Sprocket	Rochet	Spule	Piñon	
	13	8A00 88230	1	Segnalatore folle	Idle trasponder assy	Signaleur point mort compl.	Leerlauflicht kpl.	Señalador compl.	
	14	8000 71012	1	Piastrina	Plate	Plaque	Platte	Placa	
	15	8000 28327	2	Vite	Screw	Vis	Schraube	Tornillo	
	16	8C00 67997	2	Vite	Screw	Vis	Schraube	Tornillo	
	17	8000 71007	2	Saltarello per rocchetto	Click	Cliquet	Strumhaken	Salt.	
	18	8000 71008	2	Puntale per saltarello	Push rod	Embout	Stösselschaft	Puntal	
	19	8000 71009	2	Molla	Spring	Ressort	Feder	Resorte	
	20	8000 83126	1	Piastrina	Plate	Plaque	Platte	Placa	
	21	8000 82347	1	Albero com. forcelle cambio	Driving shaft gearbox forks	Arbre comm. fourches trans.	Antriebswelle Schaltgabel	Eje mando horquilla cambio	
	22	8000 38520	1	Rullino	Roller	Aiguille	Rolle	Rodillo	
	23	8000 85395	1	Cuscinetto a sfere (ø25xø42x9)	Ball bearing (ø25xø42x9)	Roulement à billes (ø25xø42x9)	Kugellager (ø25xø42x9)	Cojinete de bolas (ø25xø42x9)	
	24	8A00 97739	1	Tamburo selettore marce	Drum	Tambour	Trommel	Tambor	
	25	8000 71011	1	Vite	Screw	Vis	Schraube	Tornillo	
	26	8000 56377	1	Rosetta	Washer	Rondelle	Scheibe	Arandela	
	27	8000 71158	1	Forcella cambio (3a-4a)	Fork gearchange (3rd-4th)	Fourche boite a vitesse (3ème-4ème)	Gabel Schaltung (3°-4°)	Horquilla cambio (3a-4a)	
	28	8000 71159	1	Forcella cambio (1a-5a)	Fork gearchange (1st-5th)	Fourche boite a vitesse (1ère-5ème)	Gabel Schaltung (1°-5°)	Horquilla cambio (1a-5a)	
	29	8000 71160	1	Forcella cambio (2a-6a)	Fork gearchange (2nd-6th)	Fourche boite a vitesse (2ème-6ème)	Gabel Schaltung (2°-6°)	Horquilla cambio (2a-6a)	

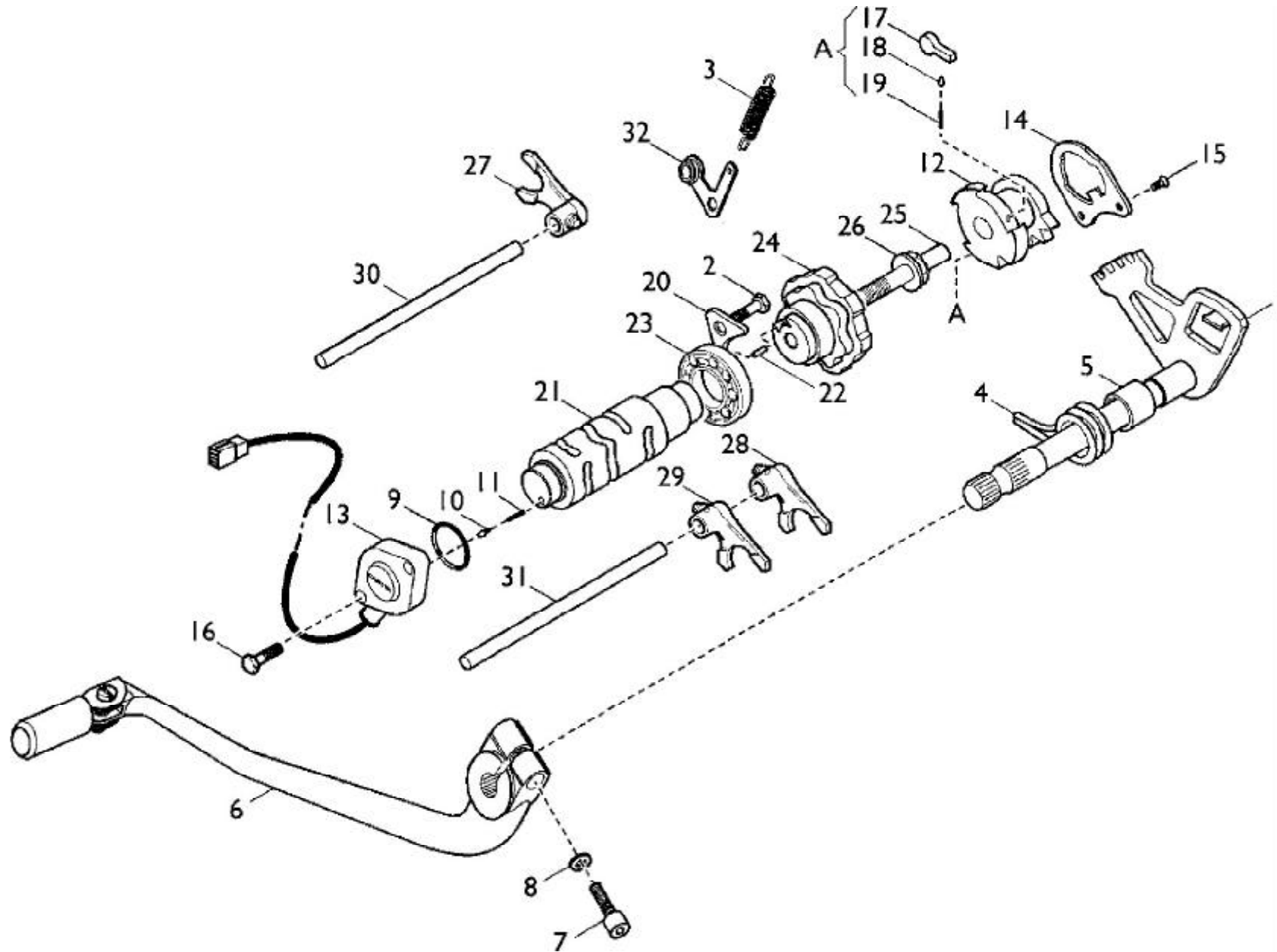

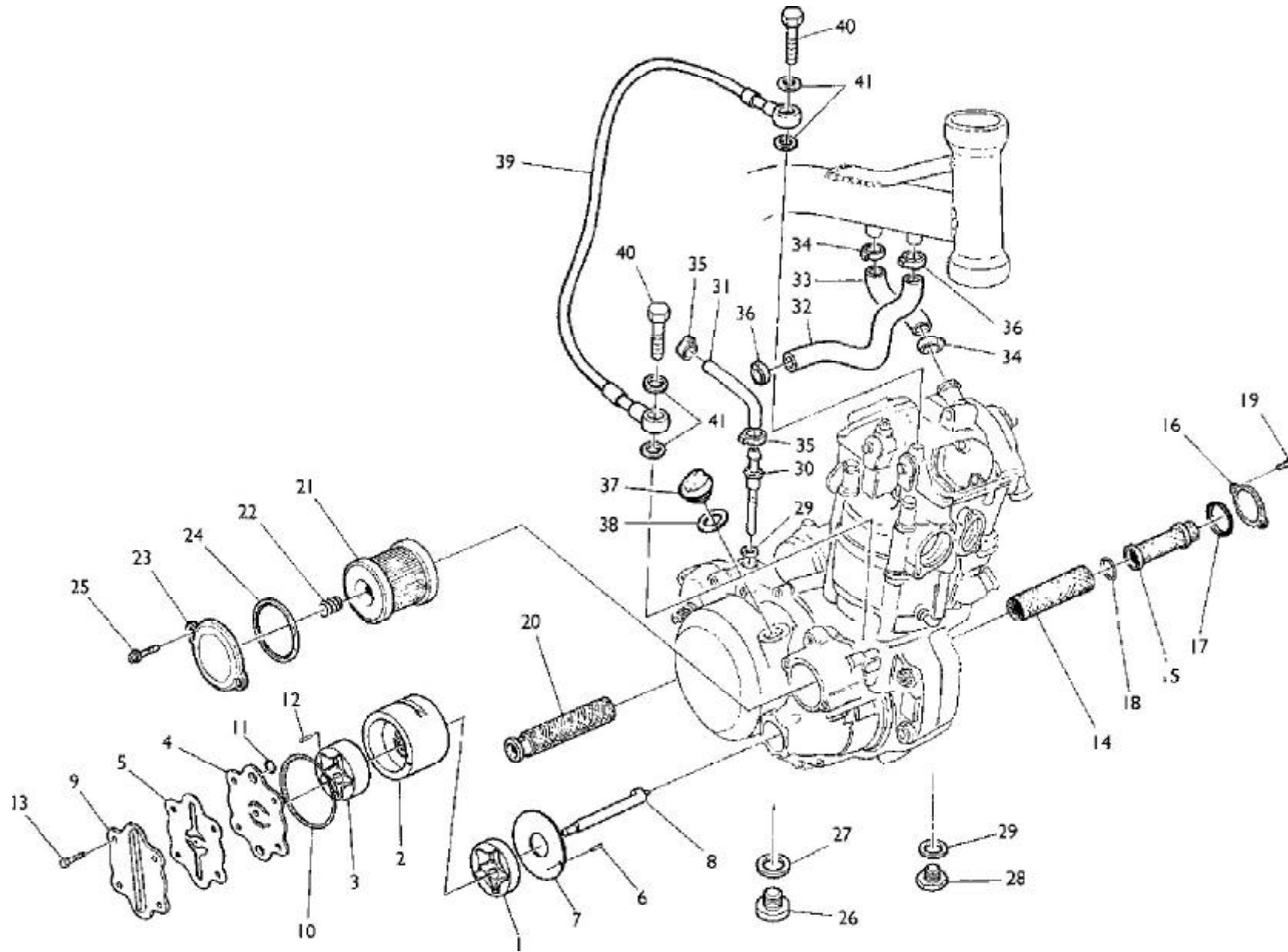

Note Notes Notas	Pos. No. Index Pos.	N. Cod. Code No. Nr. Code Code Nr N. Cod.	Q.tà Q.ty Q.te M.ge C.ad	DENOMINAZIONE	NAME	DESIGNATION	BESHREIBUNG	DENOMINACION	Validità Validity Validité Gültig Validez
	1	8A00 82948	1	Ass. rotori mandata olio	Rotor assy	Rotor compl.	Rotor kpl.	Rotor compl.	
	2	8000 73518	1	Corpo porta rotori	Pump body	Corps pompe	Pumpenkörper	Korpo Bomba	
	3	8000 82948	1	Ass. rotori recupero olio	Rotor assy	Rotor compl.	Rotor kpl.	Rotor compl.	
	4	8000 84821	1	Coperchio intermedio pompa	Cover	Couvercle	Deckel	Tapa	
	5	8000 75629	1	Guarnizione	Gasket	Guarniture	Dichtung	Junta	
	6	8B00 47773	1	Rullino di riferimento	Roller	Aiguille	Rolle	Rodillo	
	7	8000 84819	1	Distanziale interno pompa	Spacer	Entretoise int.	Distanzstück	Separador	
	8	8000 84818	1	Albero pompa lubrificazione	Shaft	Arbre	Welle	Eje	
	9	80A0 75630	1	Coperchio pompa lubrificaz.	Cover	Couvercle	Deckel	Tapa	
	10	8000 27073	1	Anello OR	O-Ring	Bague OR	O-Ring	Anillo OR	
	11	8A00 23108	2	Anello OR	O-Ring	Bague OR	O-Ring	Anillo OR	
	12	8A00 47773	2	Rullino di centraggio	Roller	Aiguille	Rolle	Rodillo	
	13	8000 62728	4	Vite	Screw	Vis	Schraube	Tornillo	
	14	8000 72426	1	Filtro a rete esterno	Filter	Filtre	Filter	Filtro	
	15	8000 72427	1	Filtro a rete interno	Filter	Filtre	Filter	Filtro	
	16	8000 72425	1	Coperchio per filtri	Cover	Couvercle	Deckel	Tapa	
	17	8000 34609	1	Anello OR	O-Ring	Bague OR	O-Ring	Anillo OR	
	18	8000 26884	1	Anello OR	O-Ring	Bague OR	O-Ring	Anillo OR	
	19	8000 66525	2	Vite	Screw	Vis	Schraube	Tornillo	
	20	8000 74716	1	Filtro a rete (lato destro)	Filter (R. H.)	Filtre (droite)	Filter (rechts)	Filtro (derech.)	
	21	8000 81675	1	Filtro olio a cartuccia	Filter	Filtre	Filter	Filtro	
	22	8000 85385	1	Molla premi filtro-cartuccia	Spring	Ressort	Feder	Resorte	
	23	80A0 78988	1	Coperchio filtro olio cartuccia	Cover	Couvercle	Deckel	Tapa	
	24	8A00 28553	1	Anello OR	O-Ring	Bague OR	O-Ring	Anillo Or	
	25	8000 62728	2	Vite	Screw	Vis	Schraube	Tornillo	
	26	8000 96747	1	Tappo scarico olio (M 22x1,5)	Plug (M 22x1,5)	Bouchon (M 22x1,5)	Verschluss (M 22x1,5)	Tapón (M 22x1,5)	
	27	62N0 15682	1	Rosetta	Washer	Rondelle	Scheibe	Arandela	
	28	8000 75415	1	Tappo scarico olio (M 14x1,25)	Plug (M 14x1,25)	Bouchon (M 14x1,25)	Verschluss (M 14x1,25)	Tapón (M 14x1,25)	
	29	62N0 15678	2	Rosetta	Washer	Rondelle	Scheibe	Arandela	
	30	8000 75293	1	Raccordo portagomma	Union	Raccord	Anschluss	Empalme	
	31	8000 88627	1	Tubo carter -telaio	Pipe crankcase-frame	Tuyau carter-chassis	Schlauch Kurberlgehäuse-Rahmen	Tubo carter-Bastidor	
	32	8000 88628	1	Tubo telaio scatola - filtro	Pipe frame - filterbox	Tuyau chassis - boite filtre	Schlauch Filterkasten-Rahmen	Tubo Bastidor - Caja filtro	

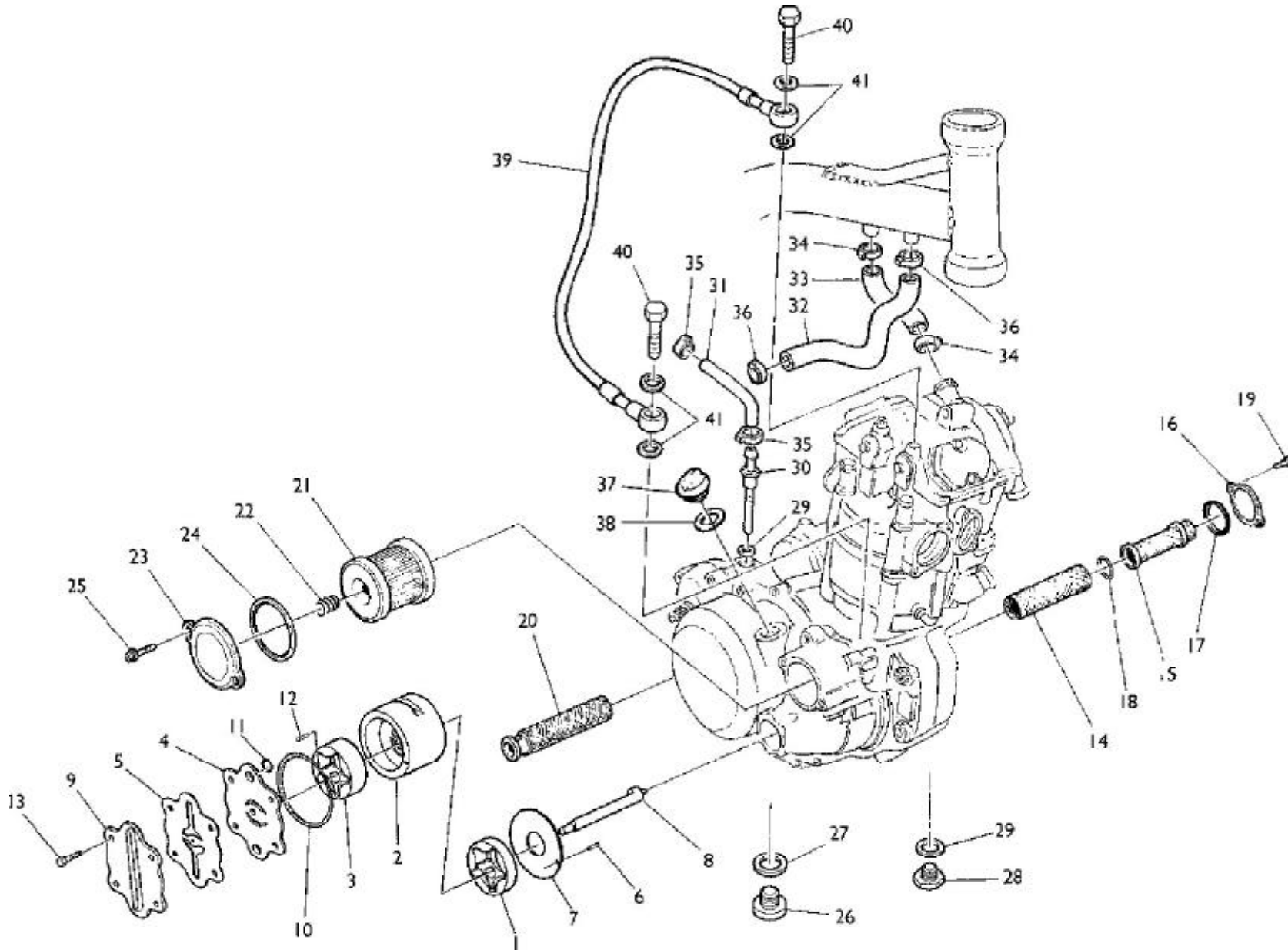

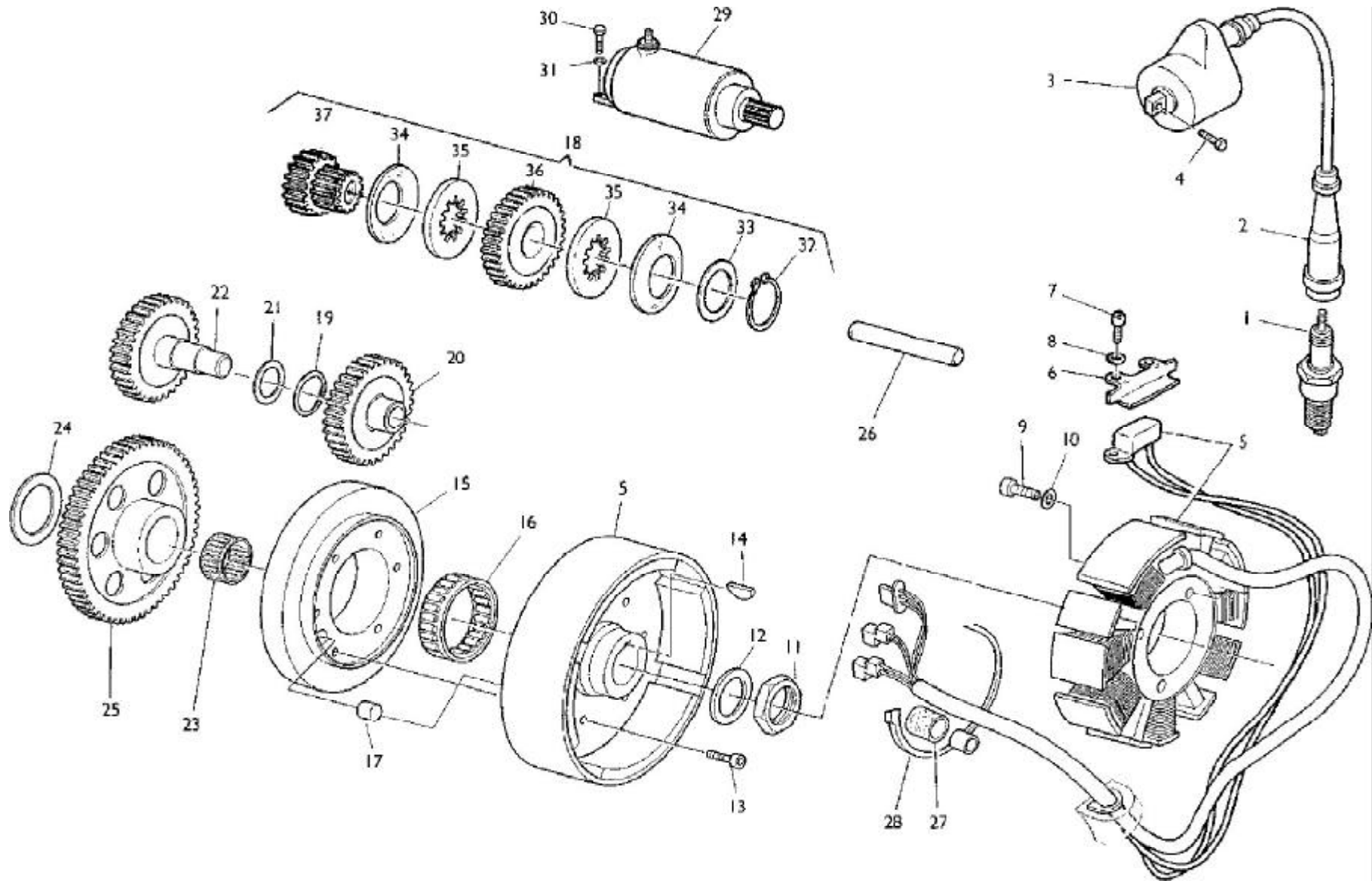

Note Notes Notas	Pos. No. N. Index Pos.	N. Cod. Code No. Nr. Code Code Nr N. Cod.	Q.tà Q.ty Q.te M.ge C.ad	DENOMINAZIONE	NAME	DESIGNATION	BESHREIBUNG	DENOMINACION	Validità Validity Validité Gültig Validez
A	1	1615 38301	1	Candela " NGK" C7E	Spark plug " NGK" C7E	Bougie " NGK" C7E	Zündkerze " NGK" C7E	Bujia " NGK" C7E	
	1	8000 77478	1	Candela "CHAMPION" G59C	Spark plug "CHAMPION" G59C	Bougie "CHAMPION" G59C	Zündkerze "CHAMPION" G59C	Bujia "CHAMPION" G59C	
	2	1615 38201	1	Cappuccio candela	Cap	Capuchon	Kappe	Capuchón	
	3	8A00 49617	1	Bobina A.T.	H.T. Coil	Bobine	Zündspule	Bobina	
	4	8000 62727	2	Vite	Screw	Vis	Schraube	Tornillo	
	5	8000 84397	1	Alternatore compl.	Alternateur compl.	Alternateur compl.	Lichtmaschine kpl.	Alternador compl.	
	6	8000 88536	1	Piastrina ritegno cavo	Plate	Plaquette	Plättchen	Placa	
	7	60N1 02461	2	Vite	Screw	Vis	Schraube	Tornillo	
	8	62N1 15534	2	Rosetta elastica	Washer	Rondelle	Scheibe	Arandela	
	9	60N1 02511	3	Vite	Screw	Vis	Schraube	Tornillo	
	10	62N1 15767	3	Rosetta	Washer	Rondelle	Scheibe	Arandela	
	11	8000 49004	1	Dado	Nut	Ecrou	Matter	Tuerca	
	12	8000 35854	1	Rosetta	Washer	Rondelle	Scheibe	Arandela	
	13	8A00 78647	6	Vite	Screw	Vis	Schraube	Tornillo	
	14	65N1 21007	1	Linguetta	Woodruff key	Clé woodruff	Federkeil	Lengüeta	
	15	8000 84828	1	Anello esterno	Ring	Bague	Ring	Anillo	
	16	8000 83136	1	Ruota libera	Free wheel	Roue libre	Freilauf	Rueda libre	
	17	8000 86051	1	Spina	Pin	Goupille	Stift	Clavija	
	18	8000 92239	1	Ingr. con frizione (Z=17/52)	Gear & clutch assy (Z=17/52)	Engrenage (Z=17/52)	Zahnrad (Z=17/52)	Engrenaje (Z=17/52)	
	19	66N0 21196	1	Anello elastico	Split ring	Anneau ressort	Sprengring	Anillo elástico	
	20	8000 84831	1	Ingran. di rinvio flottante (Z = 27)	Sliding gear (Z = 27)	Engrenage (Z = 27)	Zahnrad (Z = 27)	Engrenaje (Z = 27)	
	21	8F00 09408	1	Rosetta di rasamento	Washer	Rondelle	Scheibe	Arandela	
	22	8000 89012	1	Ingran. di rinvio (Z = 20)	Gear 2nd transmission (Z = 20)	Engrenage (Z = 20)	Zahnrad (Z = 20)	Engrenaje (Z = 20)	
	23	8000 84597	1	Gabbia a rullini (ø28xø34x20mm)	Needle cage (ø28xø34x20mm)	Cage à aiguilles (ø28xø34x20mm)	Nadelkaefig (ø28xø34x20mm)	Casquillo(ø28xø34x20mm)	
	24	8A00 84473	1	Rosetta di rasamento	Washer	Rondelle	Scheibe	Arandela	
	25	8000 89011	1	Corona per ruota libera (Z = 62)	Ring gear (Z = 62)	Couronne (Z = 62)	Kranz (Z = 62)	Corona (Z = 62)	
	26	8A00 84470	1	Perno	Pin	Pivot	Bolzen	Perno	
	27	8000 90806	1	Protezione in gomma	Rubber guard	Protection	Schutz	Protección de goma	

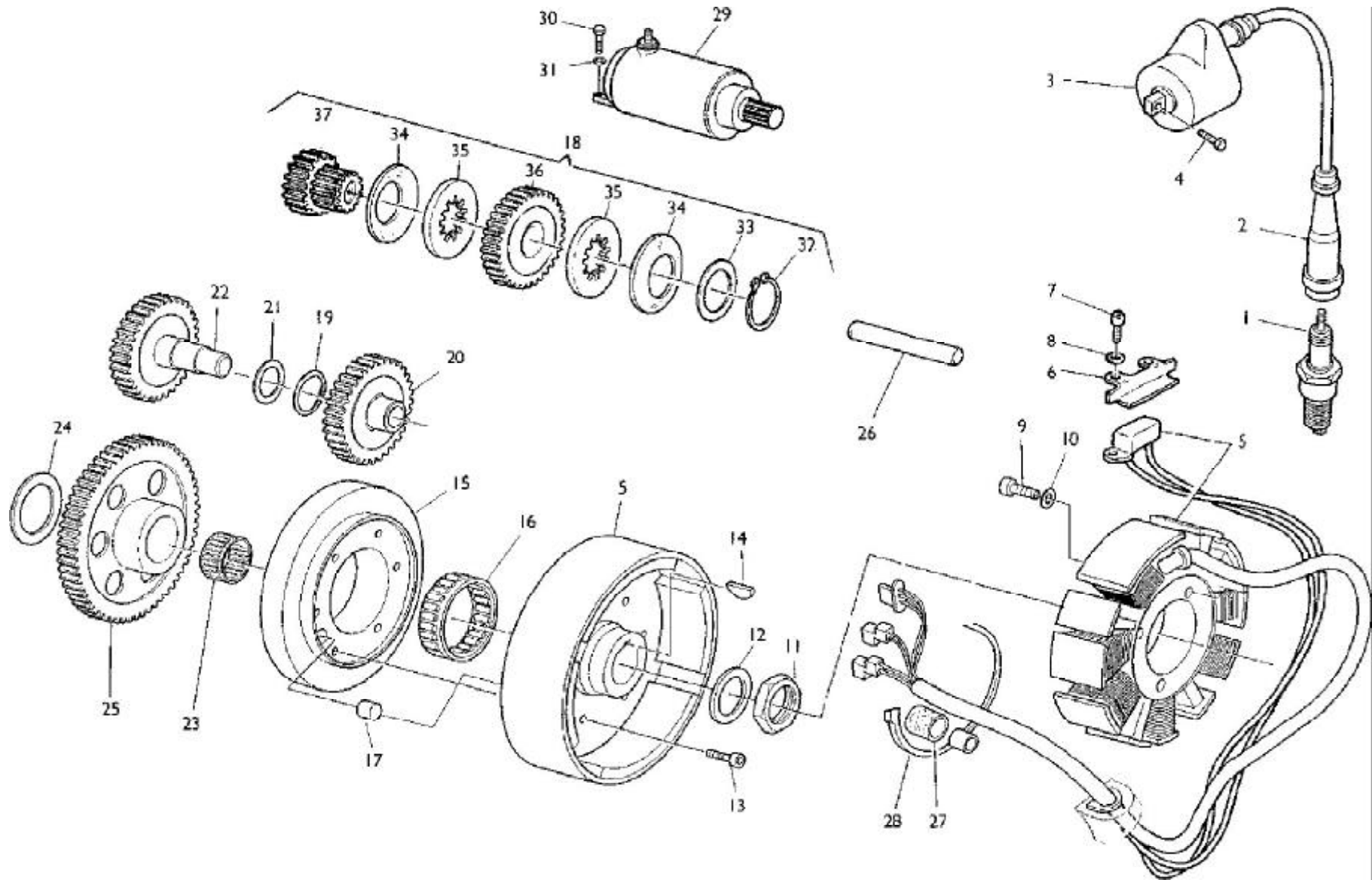

Note Notes Markes Notas	Pos. No. N. Index Pos.	N. Cod. Code No. Nr. Code Code Nr N. Cod.	Q.tà Q.ty Q.te M.ge C.ad	DENOMINAZIONE	NAME	DESIGNATION	BESHREIBUNG	DENOMINACION	Validità Validity Validité Gültig Validez
	28	8000 56444	1	Fascetta	Clamp	Collier	Schelle	Abrazadera	
	29	8000 84411	1	Ass. motorino avviamento	El. start motor	Moteur démarr. el.	Elektr Anlasser	Motor de arranque	
	30	8000 62728	2	Vite	Screw	Vis	Schraube	Tornillo	
	31	8000 48591	2	Rosetta elastica	Washer	Rondelle	Scheibe	Arandela	
	32	66N0 21217	1	Anello elastico	Ring	Anneau ressort	Sprengring	Anillo elastico	
	33	8000 85017	1	Rosetta di rasamento (0,4 mm)	Washer (0,4 mm)	Rondelle (0,4 mm)	Scheibe (0,4 mm)	Arandela (0,4 mm)	
	33	8A00 85017	1	Rosetta di rasamento (0,5 mm)	Washer (0,5 mm)	Rondelle (0,5 mm)	Scheibe (0,5 mm)	Arandela (0,5 mm)	
	33	8B00 85017	1	Rosetta di rasamento (0,6 mm)	Washer (0,6 mm)	Rondelle (0,6 mm)	Scheibe (0,6 mm)	Arandela (0,6 mm)	
	33	8C00 85017	1	Rosetta di rasamento (0,7 mm)	Washer (0,7 mm)	Rondelle (0,7 mm)	Scheibe (0,7 mm)	Arandela (0,7 mm)	
	33	8D00 85017	1	Rosetta di rasamento (0,8 mm)	Washer (0,8 mm)	Rondelle (0,8 mm)	Scheibe (0,8 mm)	Arandela (0,8 mm)	
	33	8E00 85017	1	Rosetta di rasamento (0,9 mm)	Washer (0,9 mm)	Rondelle (0,9 mm)	Scheibe (0,9 mm)	Arandela (0,9 mm)	
	33	8F00 85017	1	Rosetta di rasamento (1,0 mm)	Washer (1,0 mm)	Rondelle (1,0 mm)	Scheibe (1,0 mm)	Arandela (1,0 mm)	
	33	8G00 85017	1	Rosetta di rasamento (1,2 mm)	Washer (1,2 mm)	Rondelle (1,2 mm)	Scheibe (1,2 mm)	Arandela (1,2 mm)	
	33	8H00 85017	1	Rosetta di rasamento (1,4 mm)	Washer (1,4 mm)	Rondelle (1,4 mm)	Scheibe (1,4 mm)	Arandela (1,4 mm)	
	34	8000 85018	1	Molla a tazza	Spring	Ressort	Feder	Resorte	
	35	8000 85018	1	Disco frizione	Plate	Disque	Platte	Disco	
	36	8000 92240	1	Ingranaggio folle (Z = 52)	Gear (Z = 52)	Engrenage (Z = 52)	Zah.(Z = 52)	Engranaje (Z = 52)	
	37	8000 84832	1	Ingranaggio intermedio (Z = 17)	Gear (Z = 17)	Engrenage (Z = 17)	Zah.(Z = 17)	Engranaje (Z = 17)	

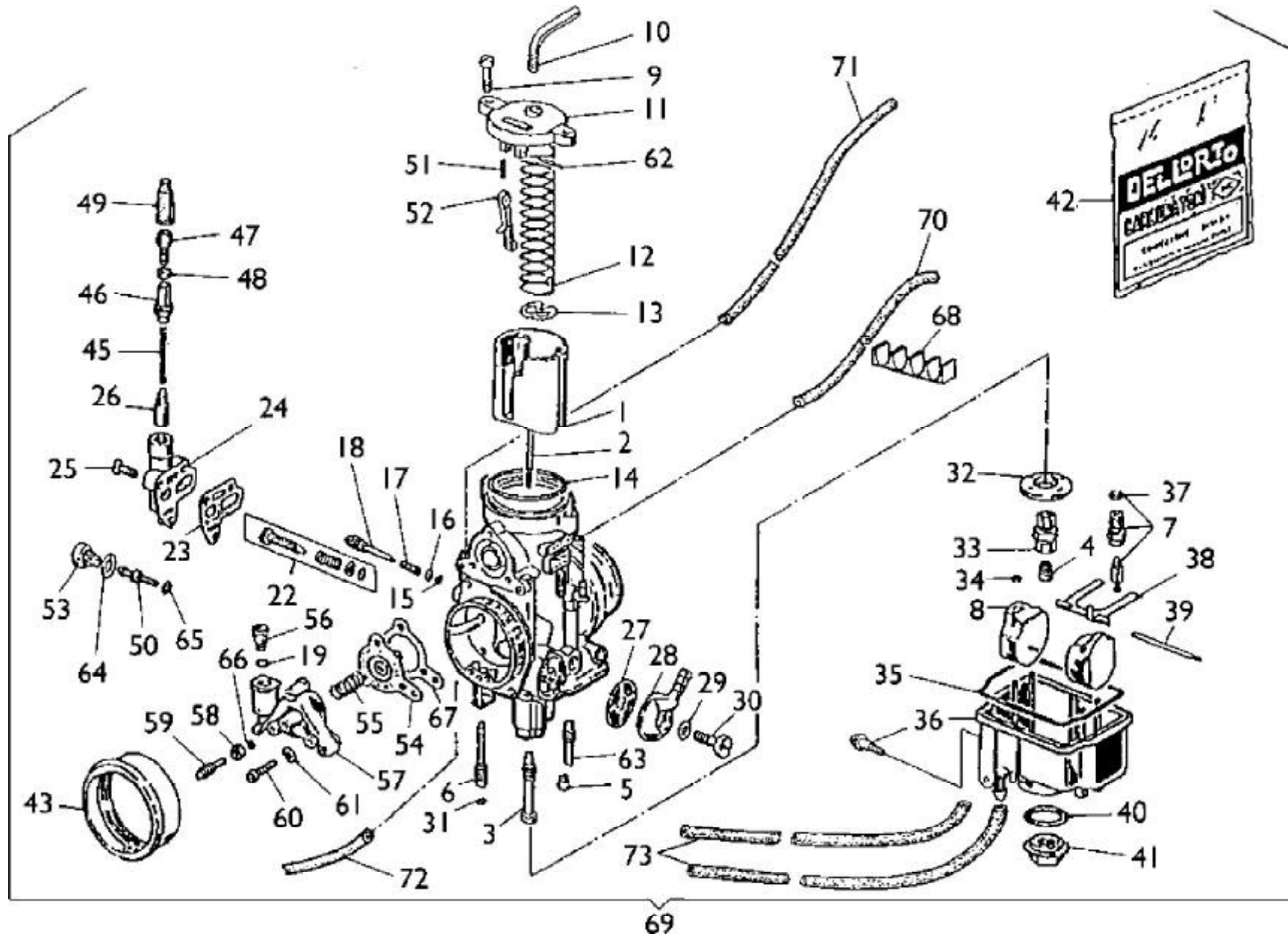

Note Notes Marke Notas	Pos. No. N. Index Pos.	N. Cod. Code No. Nr. Code Code Nr N. Cod.	Q.tà Q.ty Q.te M.ge C.ad	DENOMINAZIONE	NAME	DESIGNATION	BESHREIBUNG	DENOMINACION	Validità Validity Validité Gültig Validez
	1	8000 95695	1	Valvola gas (50/30)	Throttle valve (50/30)	Papillon de gaz (50/30)	Drosselklappe (50/30)	Válvula (50/30)	
	2	8Q00 27910	1	Spillo conico (K32)	Needle (K32)	Pointeau conique (K32)	Kon. Nadel (K32)	Pasador cónico (K32)	
	3	8A00 24058	1	Polverizzatore (260 AB)	Fuel nozzle (260 AB)	Pulvérisateur (260 AB)	Einspritzdüse (260 AB)	Pulverizador (260 AB)	
R	3	8C00 24058	1	Polverizzatore (262 AB)	Fuel nozzle (262 AB)	Pulvérisateur (262 AB)	Einspritzdüse (262 AB)	Pulverizador (262 AB)	
	4	8AP0 12041	1	Getto massimo (180)	Main jet (180)	Gicleur principal (180)	Hauptdüse (180)	Chiclé máximo (180)	
	5	8NA0 05761	1	Getto minimo (50)	Idle jet (50)	Gicleur minimum (50)	Leerlaufdüse (50)	Chiclé minimo (50)	
R	5	80C0 05761	1	Getto minimo (55)	Idle jet (55)	Gicleur minimum (55)	Leerlaufdüse (55)	Chiclé minimo (55)	
	6	80L0 12032	1	Getto avviamento (50)	Starting jet (50)	Gicleur de starter (50)	Starterdüse (50)	Chiclé arranque (50)	
	7	8000 33109	1	Valvola a spillo (300)	Needle valve (300)	Soupape á pointeau (300)	Nadelventil (300)	Válvula de aguja (300)	
	8	8000 90231	2	Galleggiante (g.4)	Float (g.4)	Flotteur (g.4)	Schwimmer (g.4)	Flotador (g.4)	
	9	8000 23981	2	Vite	Screw	Vis	Schraube	Tornillo	
	10	8000 67457	1	Tubetto	Tube	Tuyau	Rohr	Tubo	
	11	8000 60480	1	Coperchio	Cover	Couvercle	Deckel	Tapa	
	12	8000 22466	1	Molla	Spring	Ressort	Feder	Resorte	
	13	8000 23979	1	Fermaglio	Retainer	Arret	Klammer	Abrazadera de sujeción	
H	14		1	Guarnizione	Gasket	Garniture	Dichtung	Junta	
H	15		1	Guarnizione	Gasket	Garniture	Dichtung	Junta	
	16	8000 23985	1	Rosetta piana	Washer	Rondelle	Scheibe	Arandela	
	17	8000 12034	1	Molla	Spring	Ressort	Feder	Resorte	
	18	8000 47985	1	Vite regolazione minimo	Idling mixture adj. screw	Vis réglage mélange de ralenti	Regulierschraube	Tornillo regul. mezcla relenti	
	22	8000 94621	1	Kit vite registro valvola gas	Throttle adj. screw kit	Kit vis réglage papillons	Drosseleinstellschraube Kit	Kit Tornillo	
H	23		1	Guarnizione	Gasket	Garniture	Dichtung	Junta	
	24	8000 28799	1	Corpo dispositivo avviamento	Starter body	Corps démarrage	Körper Anlass	Cuerpo puesta en marcha	
	25	8000 28798	1	Vite	Screw	Vis	Schraube	Tornillo	
	26	8000 40580	1	Dispositivo avviamento	Starting device	Dispositif de démarrage	Startvorrichtung	Dispositivo puesta en marcha	
	27	8000 12045	1	Filtro benzina	Fuel filter	Filtre essence	Benzinfilter	Filtro gasolina	
	28	8000 12046	1	Pipetta	Pipette	Pipette	Pipette	Pipa	
H	29		1	Guarnizione	Gasket	Garniture	Dichtung	Junta	
	30	8000 12048	1	Vite	Screw	Vis	Schraube	Tornillo	
H	31		1	Guarnizione	Gasket	Garniture	Dichtung	Junta	
	32	8000 32866	1	Fondello	Bottom	Fond	Bodenscheibe	Casquillo	
	33	8000 23990	1	Portagetto	Jet-holder	Porte-gicleur	Düsensträger	Porta-chiclé	
	34	8000 32865	1	Fermaglio	Retainer	Arret	Klammer	Abrazadera de sujeción	

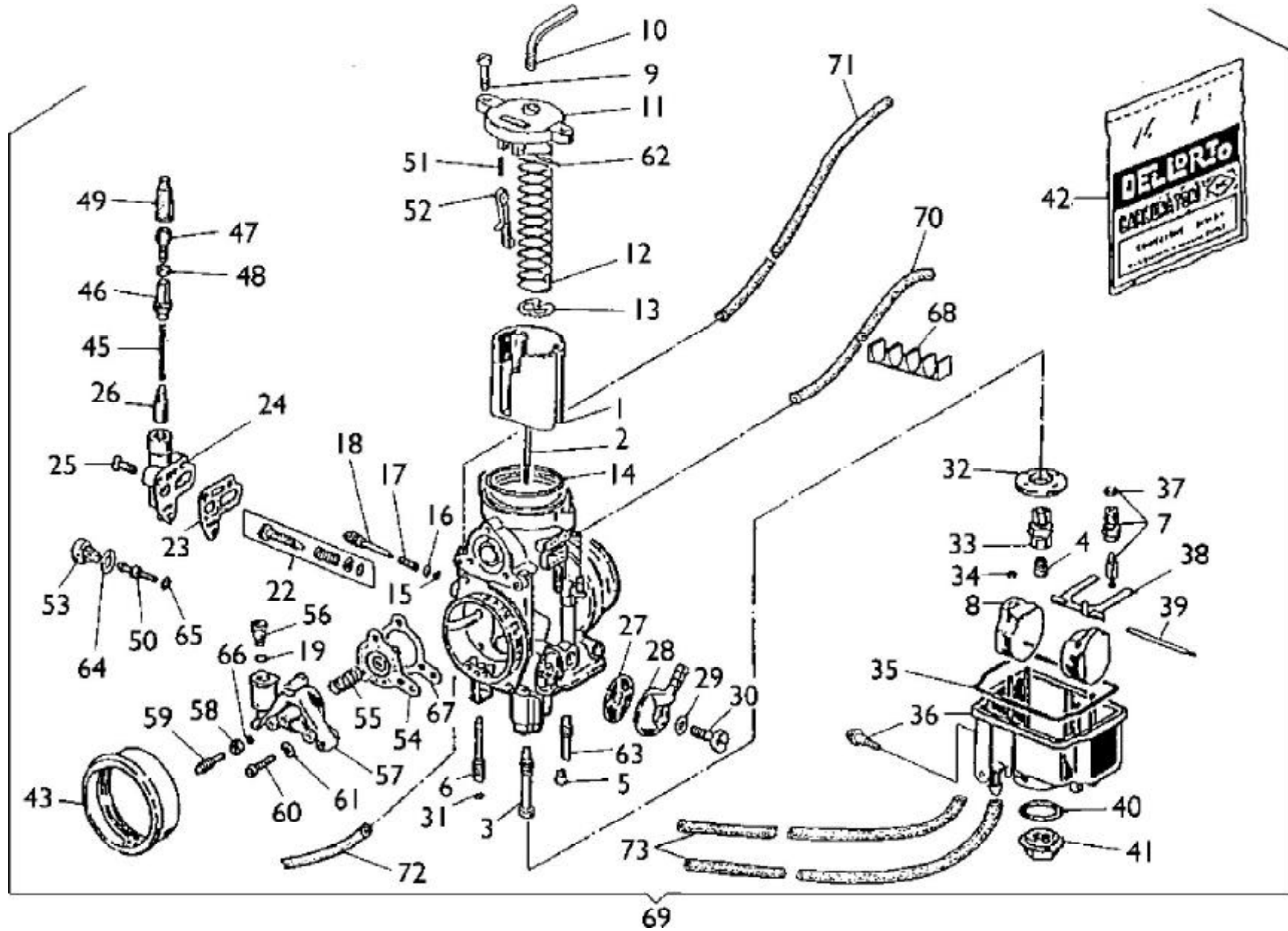

Note Notes Notas	Pos. No. N. Index Pos.	N. Cod. Code No. Nr. Code Code Nr N. Cod.	Q.tà Q.ty Q.te M.ge C.ad	DENOMINAZIONE	NAME	DESIGNATION	BESHREIBUNG	DENOMINACION	Validità Validity Validité Gültig Validez
H	35		1	Guarnizione	Gasket	Garniture	Dichtung	Junta	
	36	8000 95269	1	Vaschetta completa	Chamber assy.	Cuvette compl.	Becken kpl	Cubeta compl.	
H	37		1	Guarnizione	Gasket	Garniture	Dichtung	Junta	
	38	8000 60501	1	Bilanciere	Rocking lever	Balancier	Schwinge	Balancines	
	39	8000 32867	1	Perno	Pin	Pivot	Bolzen	Perno	
H	40		1	Guarnizione	Gasket	Garniture	Dichtung	Junta	
	41	8000 33211	1	Tappo	Plug	Bouchon	Verschluss	Tapón	
	42	8000 77879	1	Busta guarnizioni	Gasket set	Jeu joints	Dichtungssatz	Serie juntas	
	43	1615 39001	1	Cornetto presa aria	Pipe	Manchon	Muffe	Tubo toma aire	
	45	8000 44043	1	Molla	Spring	Ressort	Feder	Resorte	
	46	8000 67458	1	Tappo	Plug	Bouchon	Verschluss	Tapón	
	47	8000 04103	1	Vite	Screw	Vis	Schraube	Tornillo	
	48	8000 04104	1	Dado	Nut	Ecrou	Mutter	Tuerca	
	49	8000 12451	1	Cappuccio	Cap	Capuchon	Kappe	Capuchón	
	50	80A0 40596	1	Getto pompa (30)	Pump jet (30)	Gicleur pompe (30)	Pumpendüse (30)	Chiclé bomba (30)	
	51	8000 40586	1	Molla	Spring	Ressort	Feder	Resorte	
	52	8000 42955	1	Leva coman. pompa	Lever	Levier	Hebel	Palanca	
	53	8000 40597	1	Portagetto	Jet-holder	Porte-gicleur	Düsenträger	Porta-chiclé	
	54	8000 40593	1	Membrana pompa	Pump diaphragm	Diaphragme pompe	Pumpenmembrane	Membrana bomba	
	55	8000 40594	1	Molla	Spring	Ressort	Feder	Resorte	
	56	8000 40595	1	Valvola mandata pompa	Pump del. valve	Soupape réfoul. pompe	Pumpendruckventil	Válvula envío bomba	
	57	8000 40588	1	Coperchio	Cover	Couvercle	Deckel	Tapa	
	58	8000 40592	1	Dado	Nut	Ecrou	Mutter	Tuerca	
	59	8000 40591	1	Vite	Screw	Vis	Schraube	Tornillo	
	60	8000 40589	3	Vite	Screw	Vis	Schraube	Tornillo	
	61	8000 40590	3	Rosetta	Washer	Rondelle	Scheibe	Arandela	
	62	8000 40587	1	Perno leva coman. pompa	Pin	Pivot	Bolzen	Perno	
	63	8000 40584	1	Valvola aspirazione	Inlet valve	Soupape admission	Einlass-Ventil	Válvula aspiración	
H	64		1	Guarnizione	Gasket	Garniture	Dichtung	Junta	
H	65		1	Guarnizione	Gasket	Garniture	Dichtung	Junta	
H	66		1	Guarnizione	Gasket	Garniture	Dichtung	Junta	
H	67		1	Guarnizione	Gasket	Garniture	Dichtung	Junta	
	68	8000 67558	1	Graffetta tubi sfiato	Clip	Agrafe	Klemmstueck	Clip	

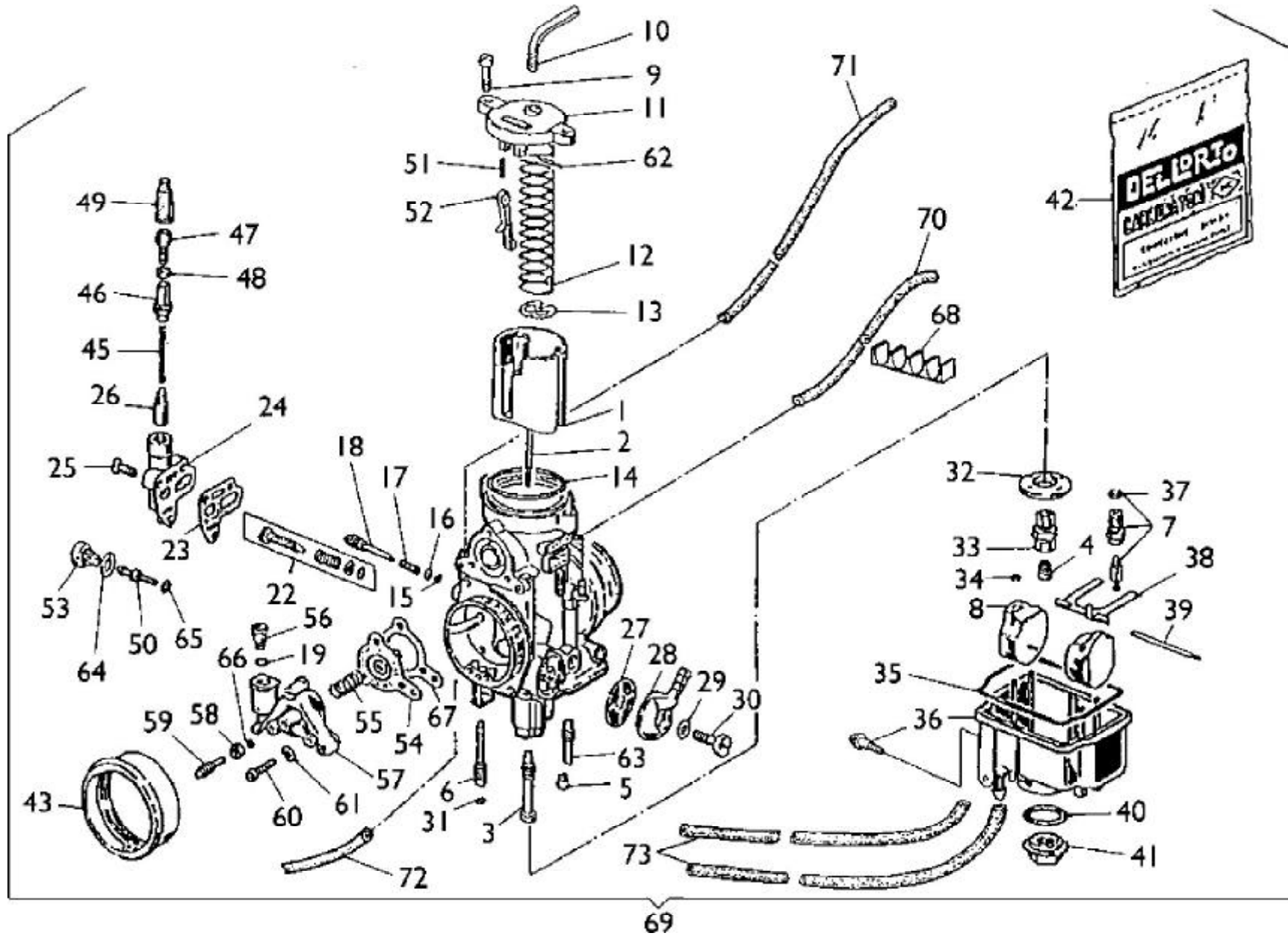

Note Notes Notes Marke Notas	Pos. No. N. Index Pos.	N. Cod. Code No. Nr. Code Code Nr N. Cod.	Q.tà Q.ty Q.te M.ge C.ad	DENOMINAZIONE	NAME	DESIGNATION	BESHREIBUNG	DENOMINACION	Validità Validity Validité Gültig Validez
	69	8000 94623	1	Carburatore completo	Carburetor assy	Carbureteur compl.	Vergaser kpl.	Carburador compl.	
*	70	8A00 60522	1	Tubetto sfiato (L = 670 mm)	Breather pipe (L = 670 mm)	Tuyau (L = 670 mm)	Rohr (L = 670 mm)	Tube de purga (L = 670 mm)	
*	71	8B00 60522	1	Tubetto sfiato(L = 750 mm)	Breather pipe (L = 750 mm)	Tuyau (L = 750 mm)	Rohr (L = 750 mm)	Tube de purga (L = 750 mm)	
*	72	8A00 60523	1	Tubetto sfiato (L = 480 mm)	Breather pipe (L = 480 mm)	Tuyau (L = 480 mm)	Rohr (L = 480 mm)	Tube de purga (L = 480 mm)	
*	73	8D00 60523	2	Tubetto sfiato (L = 400 mm)	Breather pipe (L = 400 mm)	Tuyau (L = 400 mm)	Rohr (L = 400 mm)	Tube de purga (L = 400 mm)	
H				Contenuto nella busta Pos. 42	Contained in the bag No 42	Dans l'enveloppe à joints N 42	Imbeutel d. Dichtungen Index42	En el saquito Po.42	

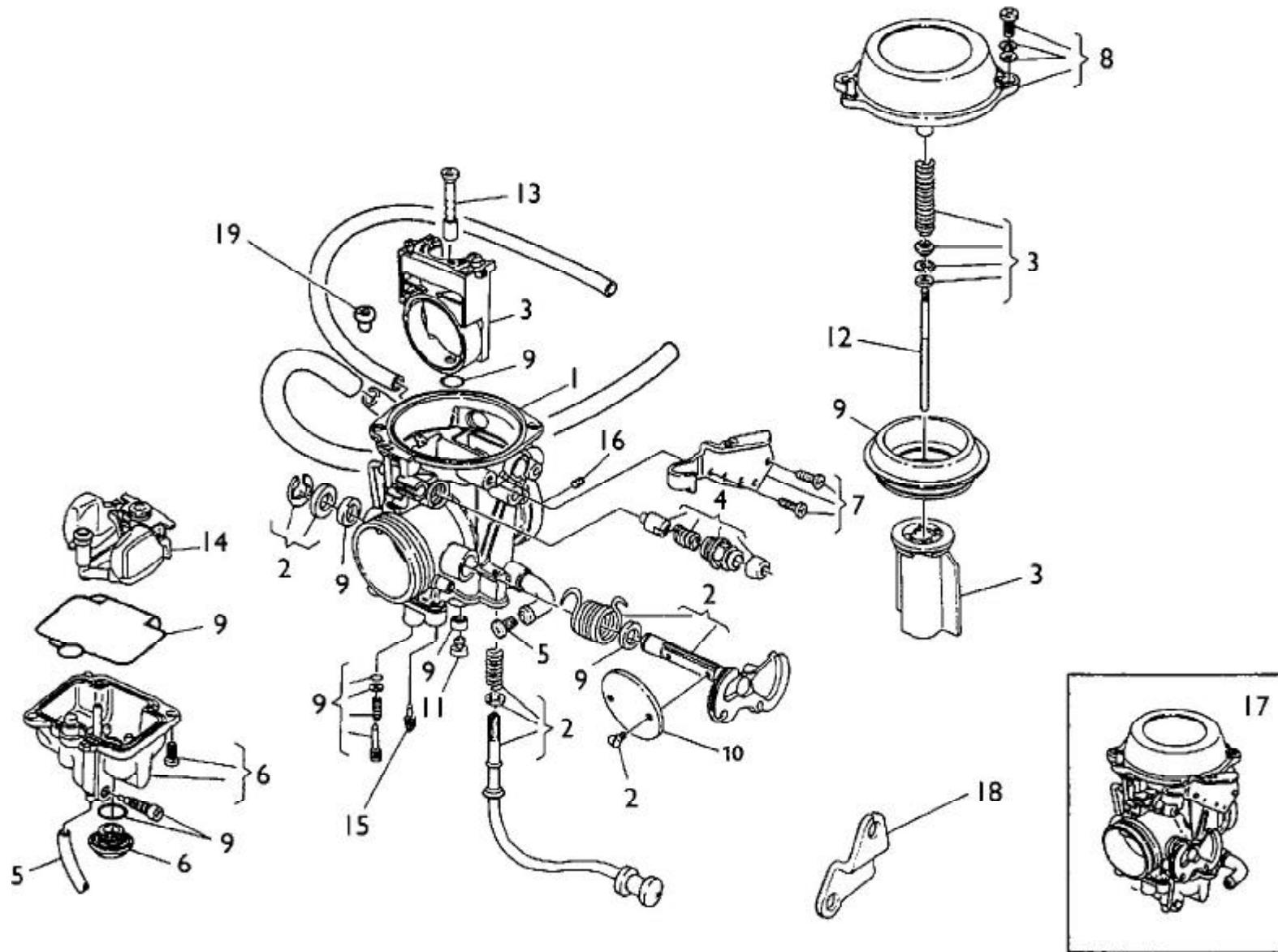

Note Notes Notas	Pos. No. N. Index Pos.	N. Cod. Code No. Nr. Code Code Nr N. Cod.	Q.tà Q.ty Q.te M.ge C.ad	DENOMINAZIONE	NAME	DESIGNATION	BESHREIBUNG	DENOMINACION	Validità Validity Validité Gültig Validez
	1	8000 82384	1	Corpo carburatore	Carburettor body	Carburateur	Vergaser	Carburador	
	2	8A00 83332	1	Gruppo valvola gas	Throttle valve group	Groupe papillon de gaz	Drosselklappe gruppe	Grupo válvula	
	3	8000 80186	1	Gruppo presa depressione	Vacuum control group	Groupe dépression	Vakuumpgruppe	Grupo depresion	
	4	8000 80180	1	Gruppo starter	Starter group	Groupe starter	Startergruppe	Grupo starter	
	5	8000 98988	1	Gruppo tubi sfiato	Breather pipes set	Groupe tuyau	Beckengruppe	Grupo cubeta	
	6	8000 86334	1	Gruppo vaschetta	Chamber	Cuvette	Becken	Cubeta	
	7	8000 80183	1	Gruppo piastra	Plate group	Groupe plaque	Platte gruppe	Grupo placa	
	8	8000 80184	1	Coperchio	Cover	Couvercle	Deckel	Tapa	
	9	8000 80185	1	Gruppo guarnizioni	Gasket set	Groupe garnitures	Dichtungssatz	Grupo juntas	
	10	8000 80176	1	Valvola gas (110)	Throttle valve (110)	Papillon de gaz (110)	Drosselklappe (110)	Válvula (110)	
	11	8A00 80171	1	Getto massimo (162,5)	Main jet (162,5)	Gicleur principal (162,5)	Hauptdüse (162,5)	Chiclé máximo (162,5)	
	12	8000 84404	1	Spillo conico (6H11)	Needle (6H11)	Pointeau conique (6H11)	Kon. Nadel (6H11)	Pasador cónico (6H11)	
	13	8A00 80173	1	Polverizzatore (784/Y-2)	Fuel nozzle (784/Y-2)	Pulvérisateur (784/Y-2)	Einspritzdüse (784/Y-2)	Pulverizador (784/Y-2)	
	14	8000 80177	1	Gruppo galleggiante	Float assy	Groupe du lotteur	Gruppe des Schwimmer	Flotador (g.12,5)	
	15	8A00 80174	1	Getto minimo (52,5)	Idle jet (52,5)	Gicleur minimum (52,5)	Leerlaufdüse (52,5)	Chiclé minimo (52,5)	
	16	8000 80175	1	Getto aria	Air jet	Jet d'air	Luftdüse	Chiclé aire	
	17	8000 98922	1	Carburatore completo	Carburettor assy	Carburateur compl.	Vergaser kpl	Carburador compl.	
	18	8000 82607	1	Piastrina	Plate	Plaquette	PLatte	Placaregul. mezcla relenti	
	19	8000 99675	1	Filtro aria	Air Filter	Fltre à air	Luftfilter	Filtro aire	
	20	8000 66767	1	Fascetta	Clamp	Collier	Schelle	Banda	

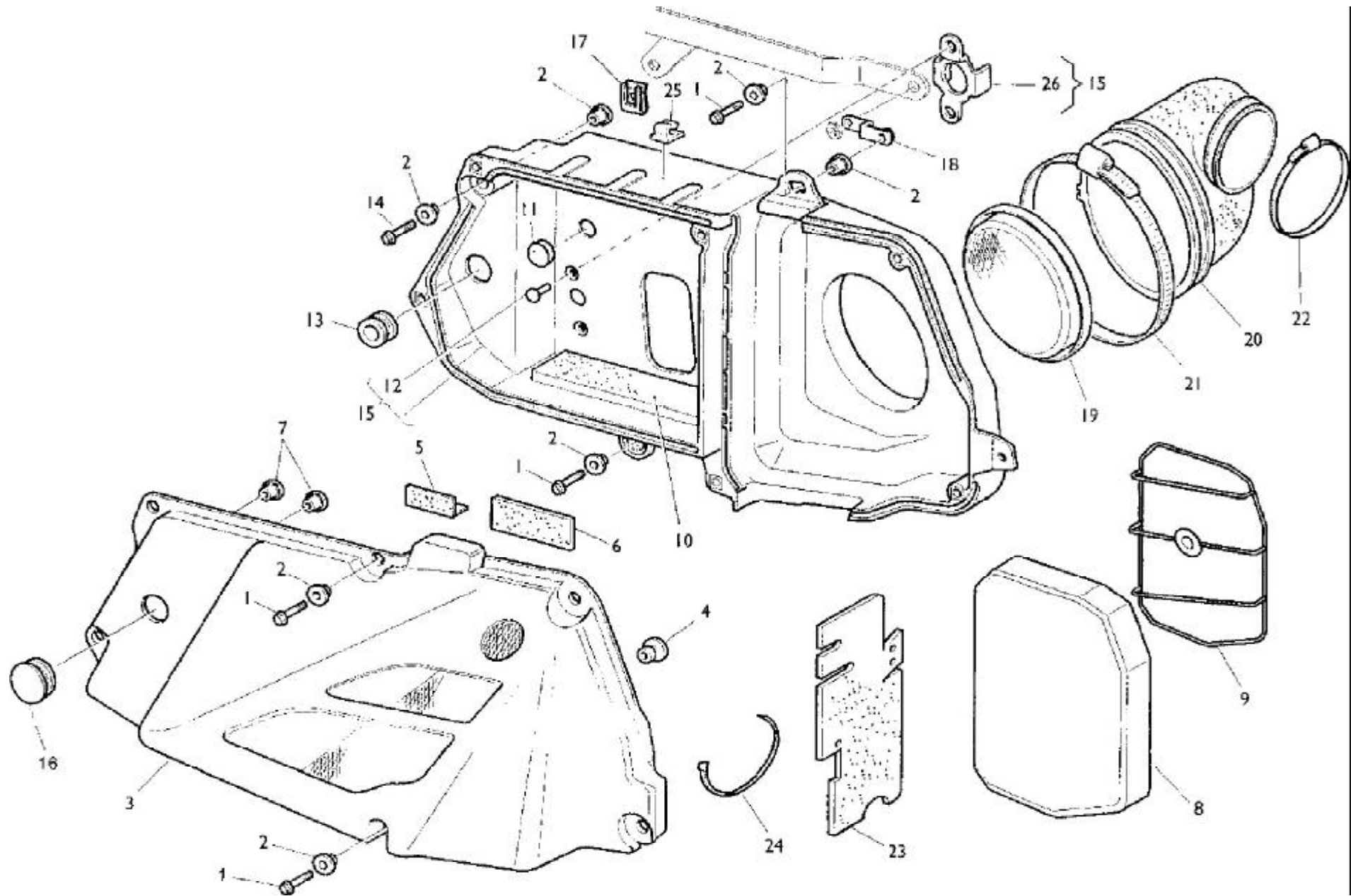

Note Notes Notes Markes Notas	Pos. No. N. Index Pos.	N. Cod. Code No. Nr. Code Code Nr N. Cod.	Q.tà Q.ty Q.te M.ge C.ad	DENOMINAZIONE	NAME	DESIGNATION	BESHREIBUNG	DENOMINACION	Validità Validity Validité Gültig Validez
	1	8000 62727	7	Vite	Screw	Vis	Schraube	Tornillo	
	2	8000 45495	10	Bussola	Bushing	Douille	Buchse	Manguito	
SS	3	8000 95452	1	Coperchio scatola filtro	Filter box cover	Couvercle boite filtre	Filtergahäusedeckel	Tapa caja filtro	
TTE	3	8000 84306	1	Coperchio scatola filtro	Filter box cover	Couvercle boite filtre	Filtergahäusedeckel	Tapa caja filtro	
TT	3	8000 95452	1	Coperchio scatola filtro	Filter box cover	Couvercle boite filtre	Filtergahäusedeckel	Tapa caja filtro	
	4	8000 67970	1	Tampone	Pad	Tampon	Stopfen	Tampón	
	5	8000 84414	1	Tampone	Pad	Tampon	Stopfen	Tampón	
	6	8A00 37140	1	Antivibrante	Silent-block	Antivibration	Schwingungsdämpfer	Anti-vibrador	
	7	8000 78181	2	Tampone	Pad	Tampon	Stopfen	Tampón	
	8	8000 84308	1	Filtro aria	Air Filter	Fltre ° air	Luftfilter	Filtro aire	
	9	8000 84309	1	Telaio di sostegno	Support	Support	Rahmen	Bastidor	
	10	8A00 30342	1	Antivibrante	Silent-block	Antivibration	Schwingungsdämpfer	Anti-vibrador	
	11	8000 55101	4	Tappo	Plug	Bouchon	Verschluss	Tapón	
	12	8000 33371	2	Rivetto a strappo	Rivet	Rivet	Niet	Remache	
	13	8000 59803	1	Gommino passacavo	Rubber pad	Piece caoutchouc	Gummistück	Junta de goma	
	14	8000 62728	1	Vite	Screw	Vis	Schraube	Tornillo	
	15	8000 95454	1	Ass. base scatola filtro	Air box filter assy	Boite filtre comp.	Filterkasten kpl.	Caja filtro aire compl.	
	16	80A0 87427	1	Tappo	Plug	Bouchon	Verschluss	Tapón	
	17	8000 46893	1	Dado a graffetta	Nut	Ecrou	Mutter	Tuerca	
	18	8000 84261	1	Piastrina	Plate	Plaque	Platte	Placa	
	19	8000 75673	1	Protezione antifiama	Guard	Protection	Schutz	Protección	
SS	20	8A00 75672	1	Raccordo	Union	Raccord	Anschluss	Empalme	
TT	20	8000 75672	1	Raccordo	Union	Raccord	Anschluss	Empalme	
	21	8F00 99475	1	Fascetta	Clamp	Collier	Schelle	Banda	
	22	8E00 99475	1	Fascetta	Clamp	Collier	Schelle	Banda	
	23	8000 90698	1	Protezione inferiore	Lower guard	Protection inferieur	Unter Schutz	Protección inferior	
	24	8000 56783	1	Fascetta	Clamp	Collier	Schelle	Banda	
	25	8000 56806	2	Gancio ritegno cavi	Hook	Crochet	Haken	Gancho	
	26	8000 86074	1	Piastrina sostegno teleruttore	Plate	Plaque	Platte	Placa	

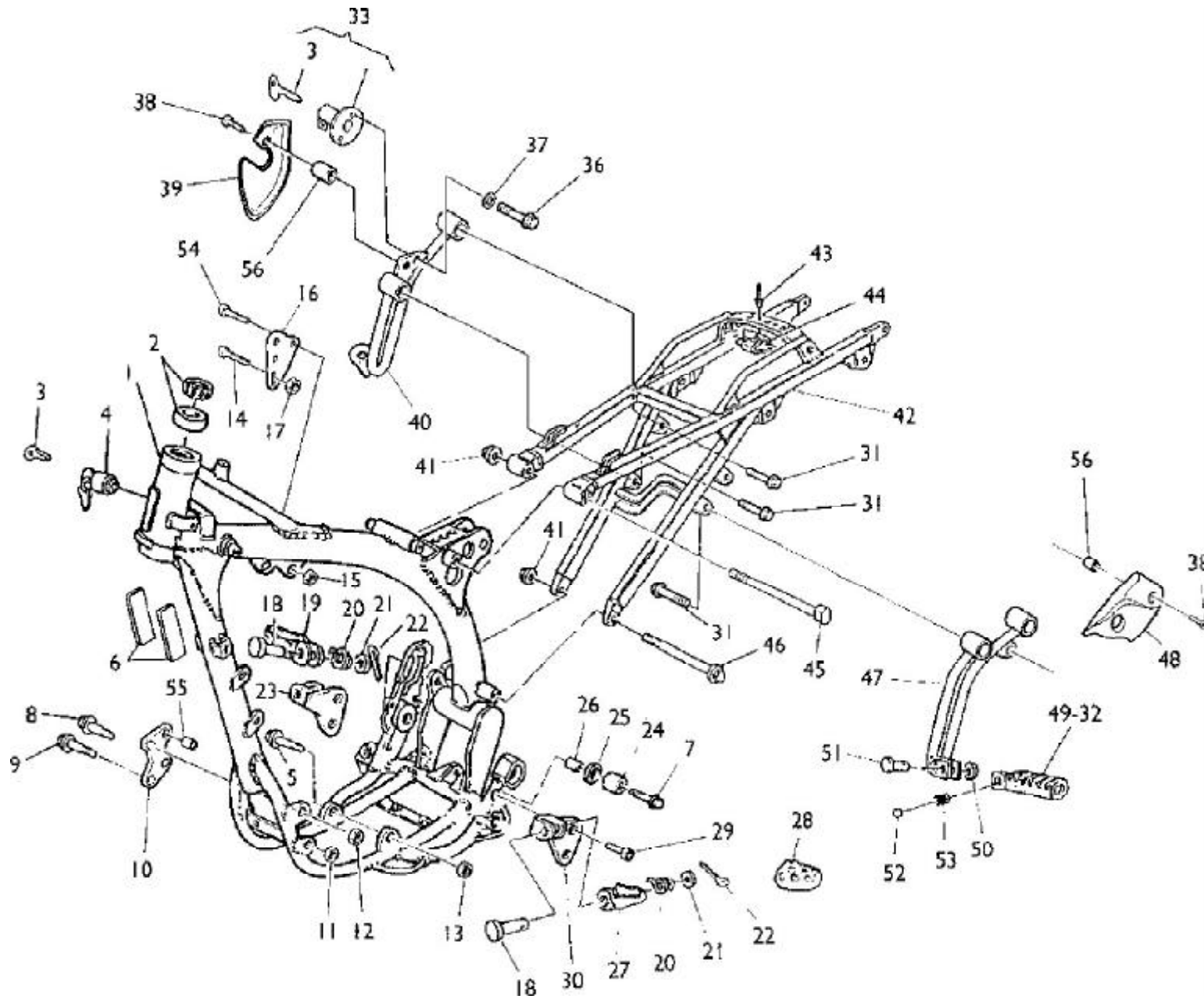

Note Notes Notas	Pos. No. Index Pos.	N. Cod. Code No. Nr. Code Code Nr N. Cod.	Q.tà Q.ty Q.te M.ge C.ad	DENOMINAZIONE	NAME	DESIGNATION	BESHREIBUNG	DENOMINACION	Validità Validity Validité Gültig Validez
	1	8A00 94616	1	Telaio con cuscinetti	Frame assy.	Chassis compl.	Rahmen kpl.	Bastidor compl.	
	2	1513 07001	2	Cuscinetto (ø25xø50x17,5mm)	Bearing (ø25xø50x17,5mm)	Roulement (ø25xø50x17,5mm)	Lager (ø25xø50x17,5mm)	Cojinete (ø25xø50x17,5mm)	
	3	8000 35531	1	Chiave grezza	Raw key	Clef primitive	Schlüssel	Llave	
	4	8000 43391	1	Serratura antifurto	Anti-left lock assy	Serrure anti-vol compl.	Sicherheitsschloss kpl.	Cerradura compl.	
	5	8B00 73458	1	Vite motore (M8x130mm)	Screw (M8x130mm)	Vis (M8x130mm)	Schraube (M8x130mm)	Tornillo (M8x130mm)	
	6	8000 86004	2	Antivibrante adesivo	Silent-Hock	Antivibration	Schwingungsdämpfen	Anti-vibrador	
	7	8000 62796	2	Vite	Screw	Vis	Schraube	Tornillo	
	8	8M00 73458	2	Vite (M8x143 mm)	Screw (M8x143 mm)	Vis (M8x143 mm)	Schraube (M8x143 mm)	Tornillo (M8x143 mm)	
	9	8000 69056	4	Vite (M8x20 mm)	Screw (M8x20 mm)	Vis (M8x20 mm)	Schraube (M8x20 mm)	Tornillo (M8x20 mm)	
	10	8000 83876	2	Piastra motore	Motor plate	Plaquette moteur	Motorplättchen	Placa motor	
	11	80B0 43928	2	Dado	Nut	Ecrou	Mutter	Tuerca	
	12	8000 40720	4	Dado flangiato	Nut	Ecrou	Mutter	Tuerca	
	13	80B0 43928	1	Dado fiss. motore	Nut	Ecrou	Mutter	Tuerca	
	14	8000 62795	1	Vite (M8x50 mm)	Screw (M8x50 mm)	Vis (M8x50 mm)	Schraube (M8x50 mm)	Tornillo (M8x50 mm)	
	15	8000 44240	2	Dado	Nut	Ecrou	Mutter	Tuerca	
	16	8000 83875	1	Piastra	Plate	Plaque	platte	Placa	
	17	80B0 43928	1	Dado	Nut	Ecrou	Mutter	Tuerca	
	18	8000 73140	2	Perno	Pin	Pivot	Bolzen	Perno	
	19	8000 87200	1	Poggiapiedi Dx.	R.H. foot rest support	Support repose pied D.	R., Fussraster	Prisioneros derech. compl.	
	20	8000 73341	2	Molla	Spring	Ressort	Feder	Resorte	
	21	8A00 01815	2	Rosetta	Washer	Rondelle	Scheibe	Arandela	
	22	64N1 20068	2	Copiglia	Split pin	Goupille	Splint	Clavija	
	23	8000 87580	1	Supporto pedana dx	R.H. Support	Support D.	R. Halterung	Soporte DE.	
	24	8000 56800	2	Rullo	Roller	Aiguille	Rolle	Rodillo	
	25	8000 28810	2	Rosetta	Washer	Rondelle	Scheibe	Arandela	
	26	8000 43947	2	Distanziale	Spacer	Entretoise	Distanzstück	Separador	
	27	8000 87201	1	Poggiapiedi Sx.	L.H. foot rest support	Support repose pied G.	L., Fussraster	Prisioneros compl.	
	28	8000 87202	2	Copripedana	Rubber cover	Couverture caoutchouc	Gummstück	Cubre-pedal de goma	
	29	8000 62732	4	Vite	Screw	Vis	Schraube	Tornillo	
	30	8000 83987	1	Supporto pedana Sx.	L.H. Support	Support G.	L. Halterung	Soporte iz.	
	31	80B0 69056	3	Vite (M8x20 mm)	Screw (M8x20 mm)	Vis (M8x20 mm)	Schraube (M8x20 mm)	Tornillo (M8x20 mm)	
	31	8B00 69056	1	Vite (M8x15 mm)	Screw (M8x15 mm)	Vis (M8x15 mm)	Schraube (M8x15 mm)	Tornillo (M8x15 mm)	

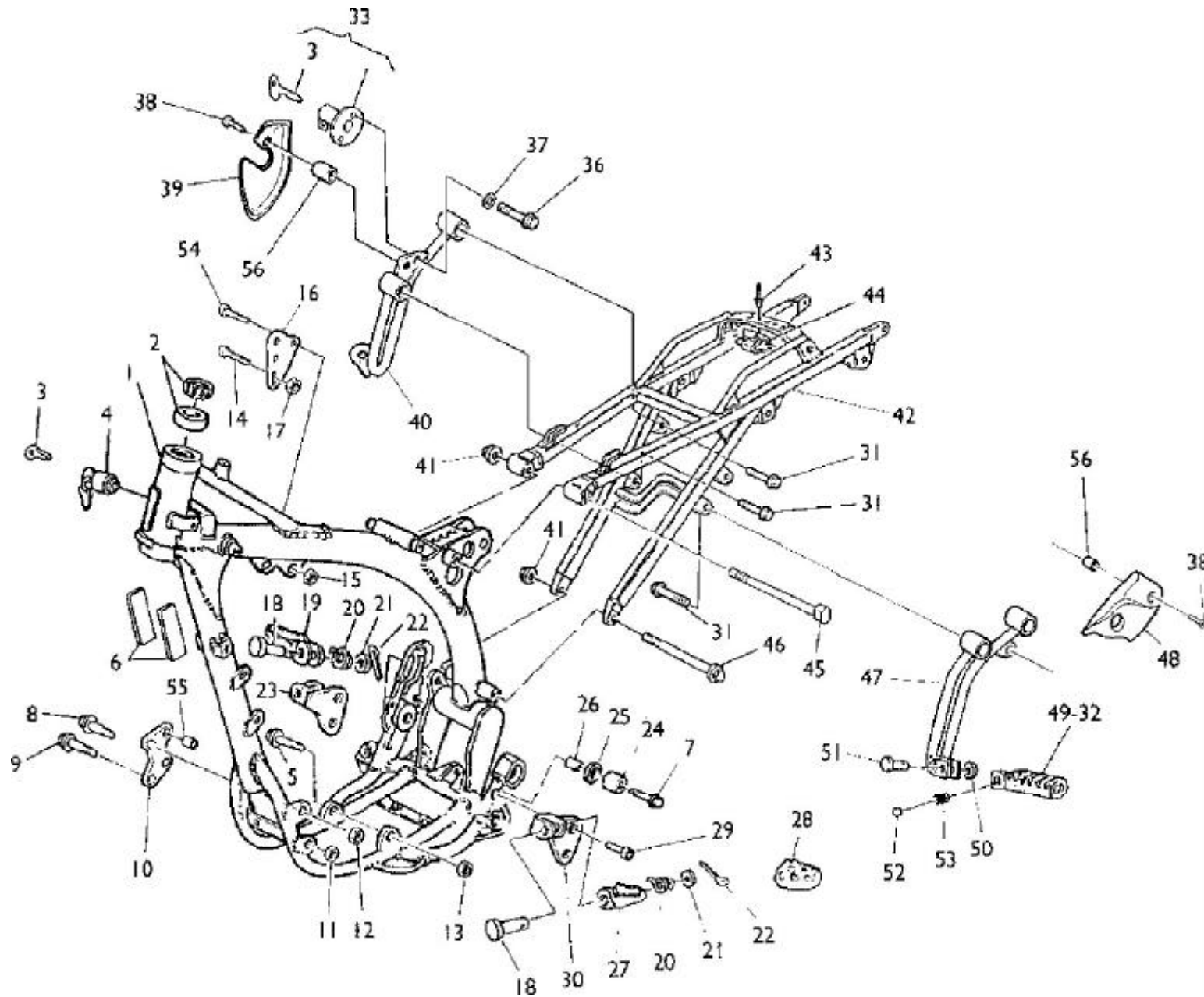

Note Notes Notas	Pos. No. N. Index Pos.	N. Cod. Code No. Nr. Code Code Nr N. Cod.	Q.tà Q.te M.ge C.ad	DENOMINAZIONE	NAME	DESIGNATION	BESHREIBUNG	DENOMINACION	Validità Validity Validité Gültig Validez
	32	8A00 85928	1	Poggiapiedi passeggero Dx.	R.H. foot rest support	Support repose pied D.	R., Fussraster	Prisioneros derech. compl.	
	33	8000 38211	1	Ass. serratura con chiavi	Lock assy with keys	Serrure compl. avecclés	Schloss kpl. mit Schlüssel	Cerradura compl. con llaves	
	36	8000 62725	2	Vite	Screw	Vis	Schraube	Tornillo	
	37	62N1 15536	2	Rosetta	Washer	Rondella	Scheibe	Arandela	
	38	8000 67997	2	Vite	Screw	Vis	Schraube	Tornillo	
	39	8000 87844	1	Copripedana Dx	Cover	Couvercle	Deckel	Tapa	
SS	40	8A00 85926	1	Supp. pogg. pass. Dx. (&)	Support (&)	Support (&)	Halterung (&)	Soporte elástico (&)	
TTE	40	8A00 85926	1	Supp. pogg. pass. Dx. (&)	Support (&)	Support (&)	Halterung (&)	Soporte elástico (&)	
TT	40	8AA0 85926	1	Supp. pogg. pass. Dx. (@)	Support (@)	Support (@)	Halterung (@)	Soporte elástico (@)	
	41	80B0 43928	2	Dado	Nut	Ecrou	Mutter	Tuerca	
	42	8A00 83999	1	Telaio posteriore	Rear frame side	Chassis arrière	Sattelbrücke	Cuadro posterior	
	43	8000 33373	2	Rivetto	Rivet	Rivet	Niet	Remache	
	44	8000 69150	1	Piastrina	Plate	Plaque	Plättchen	Placa	
	45	8L00 73458	1	Vite (M8x105 mm)	Screw (M8x105 mm)	Vis (M8x105 mm)	Schraube (M8x105 mm)	Tornillo (M8x105 mm)	
	46	8000 69056	2	Vite (M8x20 mm)	Screw (M8x20 mm)	Vis (M8x20 mm)	Schraube (M8x20 mm)	Tornillo (M8x20 mm)	
SS	47	8A00 85927	1	Supp. pogg. pass. Sx. (&)	Support (&)	Support (&)	Halterung (&)	Soporte elástico (&)	
TTE	47	8A00 85927	1	Supp. pogg. pass. Sx. (&)	Support (&)	Support (&)	Halterung (&)	Soporte elástico (&)	
TT	47	8AA0 85927	1	Supp. pogg. pass. Sx. (@)	Support (@)	Support (@)	Halterung (@)	Soporte elástico (@)	
	48	8000 87845	1	Copripedana Sx.	Cover	Couvercle	Deckel	Tapa	
	49	8A00 85929	1	Poggiapiedi passeggero Sx.	L.H. foot rest support	Support repose pied G.	L., Fussraster	Prisioneros compl.	
	50	66N1 21308	2	Anello elastico	Split ring	Anneau ressort	Sprengring	Anillo elástico	
	51	8B00 53546	2	Perno	Pin	Pivot	Bolzen	Perno	
	52	6BN0 21507	2	Sfera (1/4")	Ball (1/4")	Bille (1/4")	Kugel (1/4")	Estera (1/4")	
	53	8000 62655	2	Molla di arresto	Spring	Ressort	Feder	Resorte	
	54	8000 62728	2	Vite	Screw	Vis	Schraube	Tornillo	
	55	8000 86323	4	Distanziale piastra-motore	Spacer	Entretoise	Distanzstück	Separador	
	56	8000 69282	2	Bussola	Bushing	Douille	Buchse	Casquillo	

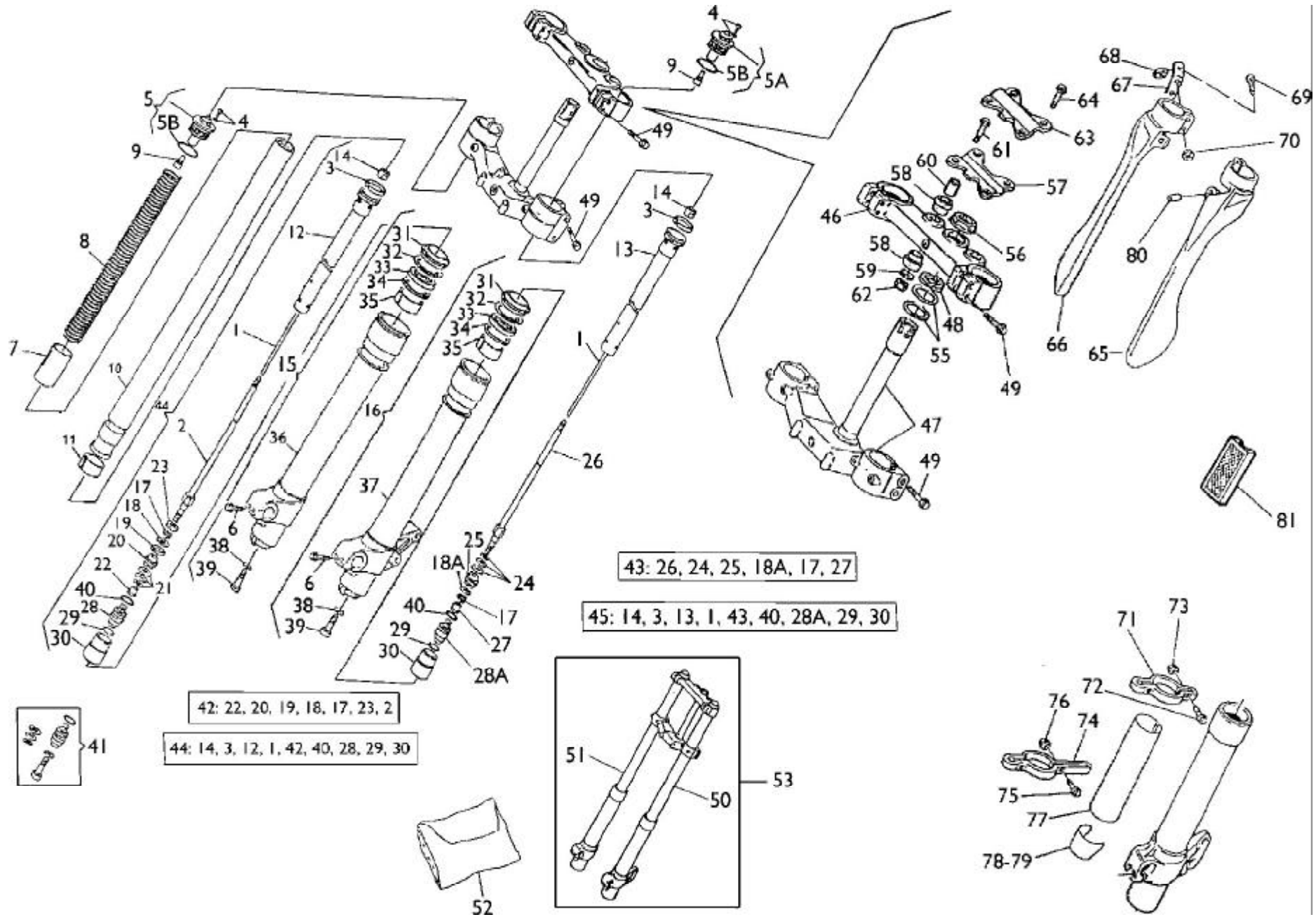

Note Notes Notas	Pos. No. Index Pos.	N. Cod. Code No. Nr. Code Code Nr N. Cod.	Q.tà Q.ty Q.te M.ge C.ad	DENOMINAZIONE	NAME	DESIGNATION	BESHREIBUNG	DENOMINACION	Validità Validity Validité Gültig Validez
	1	8000 89232	2	Asta interna	Internal rod	Barre	Stange	Varilla	
	2	8000 89233	1	Asta DX compl.	R.H. rod assy	BarreD. compl.	R. Stange Kpl.	Grupo varillader. compl.	
H	3	8000 81168	2	Segmento	Circlip	Segment	Colbenring	Segmento	
	4	8000 84702	2	Vite	Screw	Vis	Schraube	Tornillo	
	5	8000 89234	1	Gruppo tappo DX	R.H. plug assy	Groupe bouchon D.	R. Verschlussgruppe kpl.	Grupo tapòn der.	
	5A	8000 89235	1	Gruppo tappo SX	L.H. plug assy	Groupe bouchon G.	L. Verschlussgruppe kpl.	Grupo tapòn iz.	
H	5B	8000 70324	2	Anello OR	O-Ring	Bague OR	O-Ring	Anillo OR	
	6	8000 62729	4	Vite (M6x25mm)	Screw (M6x25mm)	Vis (M6x25mm)	Schraube (M6x25mm)	Tornillo (M6x25mm)	
SS	7	8000 97605	2	Tubetto	Pipe	Tuyau	Rohr	Tubo	
TT	7	8000 97602	2	Tubetto	Pipe	Tuyau	Rohr	Tubo	
SS	8	8000 90670	2	Molla (k= 5,5 N/mm)	Spring (k= 5,5 N/mm)	Ressort (k= 5,5 N/mm)	Feder (k= 5,5 N/mm)	Resorte (k= 5,5 N/mm)	
TT	8	8000 89518	2	Molla (k= 5,0 N/mm)	Spring (k= 5,0 N/mm)	Ressort (k= 5,0 N/mm)	Feder (k= 5,0 N/mm)	Resorte (k= 5,0 N/mm)	
	9	8000 91479	2	Gruppo registro	Adjuster set	Groupe reglage	Reglergruppe	Grupo regulaciòn	
	10	8000 84474	2	Tubo portante	Pipe	Tuyau	Rohr	Tubo	
H	11	8000 70322	2	Bussola	Bushing	Douille	Buchse	Manguito	
	12	8000 97600	2	Custodia DX	R.H. Housung	Cage D.	R. Korb	Custodia der.	
	13	8000 97601	2	Custodia SX	L.H. Housung	Cage G.	L. Korb	Custodia iz.	
	14	8000 89238	2	Dado	Nut	Ecrou	Mutter	Tuerca	
	15	8000 97604	1	Gamba Dx. compl.	R.H. fork leg assy	Fourche complete D.	Telegabel Kpl. R.	Horquilla derech. compl.	
SS	16	8000 97599	1	Gamba Sx. compl.	L.H. fork leg assy	Fourche compl. G.	Telegabel, Kpl. L.	Horquill izrda. compl.	
TT	16	8000 97603	1	Gamba Sx. compl.	L.H. fork leg assy	Fourche compl. G.	Telegabel, Kpl. L.	Horquill izrda. compl.	
	17	8000 89241	2	Molla	Spring	Ressort	Feder	Resorte	
	18	8000 89245	1	Lamella (ø23x0,2mm)	Plate (ø23x0,2mm)	Lamelle (ø23x0,2mm)	Plättchen (ø23x0,2mm)	Laminilla (ø23x0,2mm)	
	18	8000 93872	1	Lamella (ø22x0,3mm)	Plate (ø22x0,3mm)	Lamelle (ø22x0,3mm)	Plättchen (ø22x0,3mm)	Laminilla (ø22x0,3mm)	
	18	8000 91491	1	Lamella (ø21x0,3mm)	Plate (ø21x0,3mm)	Lamelle (ø21x0,3mm)	Plättchen (ø21x0,3mm)	Laminilla (ø21x0,3mm)	
	18	8000 91492	1	Lamella (ø20x0,3mm)	Plate (ø20x0,3mm)	Lamelle (ø20x0,3mm)	Plättchen (ø20x0,3mm)	Laminilla (ø20x0,3mm)	
	18A	8000 89242	1	Lamella (ø23x0,3mm)	Plate (ø23x0,3mm)	Lamelle (ø23x0,3mm)	Plättchen (ø23x0,3mm)	Laminilla (ø23x0,3mm)	
H	19	8000 89243	2	Segmento	Circlip	Segment	Colbenring	Segmento	
	20	8000 91493	1	Pistone DX	R.H. piston	Piston D.	Kolbe R.	Pistón der.	
	21	8000 89245	1	Lamella (ø23x0,2mm)	Plate (ø23x0,2mm)	Lamelle (ø23x0,2mm)	Plättchen (ø23x0,2mm)	Laminilla (ø23x0,2mm)	
	21	8000 89246	1	Lamella (ø20x0,2mm)	Plate (ø20x0,2mm)	Lamelle (ø20x0,2mm)	Plättchen (ø20x0,2mm)	Laminilla (ø20x0,2mm)	
	21	8000 89247	1	Lamella (ø22x0,2mm)	Plate (ø22x0,2mm)	Lamelle (ø22x0,2mm)	Plättchen (ø22x0,2mm)	Laminilla (ø22x0,2mm)	
	21	8000 89248	2	Lamella (ø21x0,2mm)	Plate (ø21x0,2mm)	Lamelle (ø21x0,2mm)	Plättchen (ø21x0,2mm)	Laminilla (ø21x0,2mm)	

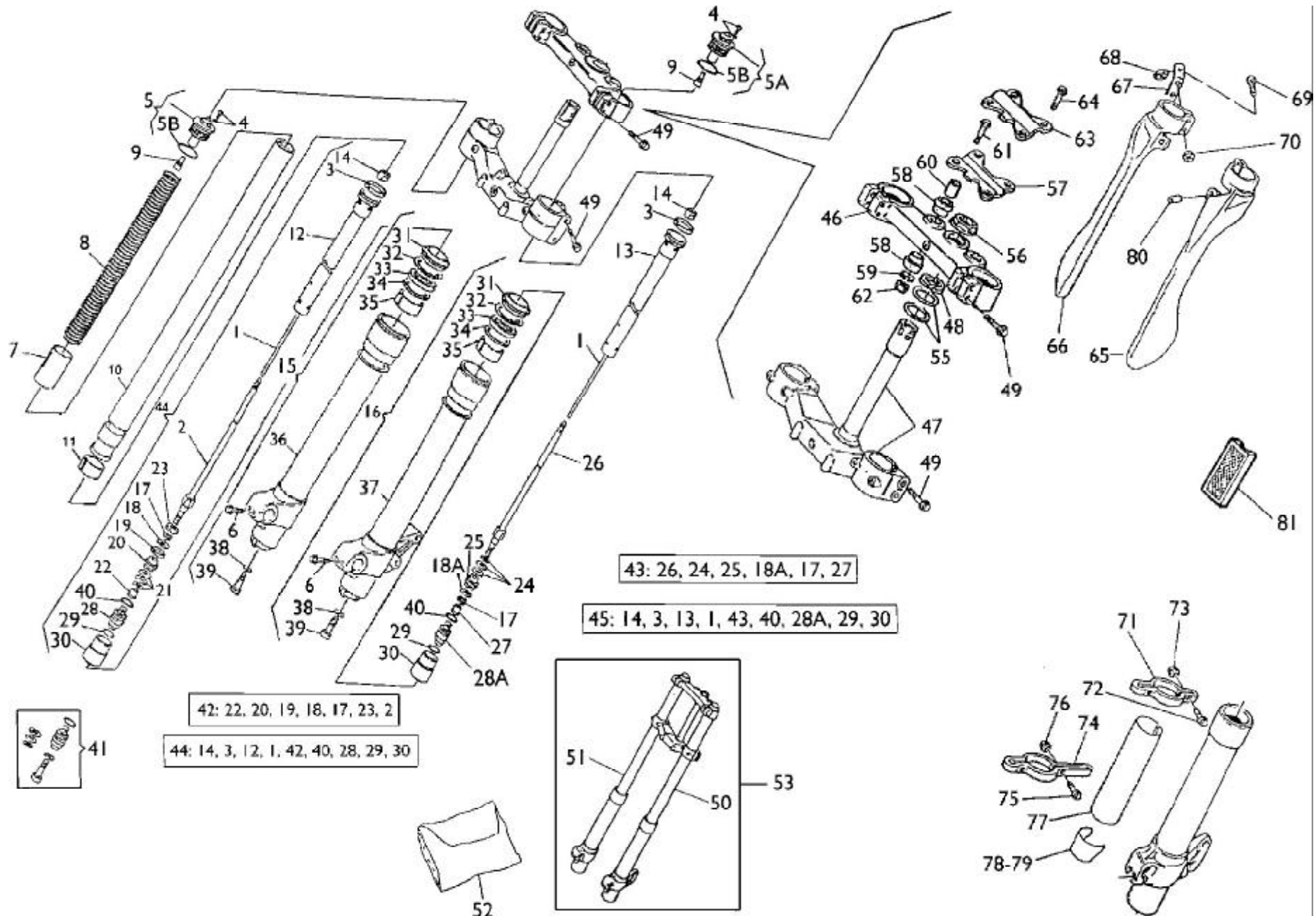

Note Notes Notes Marka Notas	Pos. No. N. Index Pos.	N. Cod. Code No. Nr. Code Code Nr N. Cod.	Q.tà Q.ty Q.te M.ge C.ad	DENOMINAZIONE	NAME	DESIGNATION	BESHREIBUNG	DENOMINACION	Validità Validity Validité Gültig Validez
	22	8000 81178	1	Dado DX	R.H. Nut	Ecrou D.	R. Mutter	Tuerca der.	
	23	8000 89249	1	Scodellino	Cup	Cuvette	Teller	Cubeta	
	24	8000 89245	1	Lamella (ø23x0,2mm)	Plate (ø23x0,2mm)	Lamelle (ø23x0,2mm)	Plättchen (ø23x0,2mm)	Laminilla (ø23x0,2mm)	
	24	8000 89247	1	Lamella (ø22x0,2mm)	Plate (ø22x0,2mm)	Lamelle (ø22x0,2mm)	Plättchen (ø22x0,2mm)	Laminilla (ø22x0,2mm)	
	24	8000 91491	1	Lamella (ø21x0,3mm)	Plate (ø21x0,3mm)	Lamelle (ø21x0,3mm)	Plättchen (ø21x0,3mm)	Laminilla (ø21x0,3mm)	
	24	8000 81181	1	Lamella (ø19x0,3mm)	Plate (ø19x0,3mm)	Lamelle (ø19x0,3mm)	Plättchen (ø19x0,3mm)	Laminilla (ø19x0,3mm)	
	24	8000 84486	1	Lamella (ø17x0,3mm)	Plate (ø17x0,3mm)	Lamelle (ø17x0,3mm)	Plättchen (ø17x0,3mm)	Laminilla (ø17x0,3mm)	
	25	8000 89250	1	Pistone SX	L.H. piston	Piston G.	Kolben L.	Pistón iz.	
	26	8000 89251	1	Asta SX compl.	L.H. rod assy	BarreG. compl.	L. Stange Kpl.	Grupo varilla iz. compl.	
	27	8000 89252	1	Dado	Nut	Ecrou	Mutter	Tuerca	
	28	8000 97606	1	Valvola di fondo DX	R.H. Valve	Soupape D.	R. Ventil	Válvula der.	
	28A	8000 89254	1	Valvola di fondo SX	L.H. Valve	Soupape G.	L. Ventil	Válvula iz.	
H	29	8000 81164	2	Anello OR	O-Ring	Bague OR	O-Ring	Anillo OR	
	30	8000 81163	2	Tampone di fondo	Pad	Tampon	Stopfen	Tampón	
H	31	8000 81162	2	Raschiapolvere	Dust scraper	Racloir poudre	Pulverabschaber	Rascador de polvo	
	32	8000 81161	2	Anello di fermo	Stop ring	Bague d'arrêt	Haltering	Anillo de retención	
H	33	8000 85930	2	Anello di tenuta	Seal ring	Bague de retenue	Dichtring	Anillo de retención	
H	34	8000 86385	1	Scodellino	Cup	Cuvette	Teller	Cubeta	
H	35	8000 70328	2	Bussola	Bushing	Douille	Buchse	Manguito	
	36	8000 97608	1	Portastelo DX	R.H. Pipe	Tuyau D.	R. Rohr	Tubo der.	
SS	37	8000 97598	1	Portastelo SX	L.H. Pipe	Tuyau G.	L. Rohr	Tubo iz.	
TT	37	8000 97603	1	Portastelo SX	L.H. Pipe	Tuyau G.	L. Rohr	Tubo iz.	
H	38	8000 31113	2	Rosetta	Washer	Rondelle	Scheibe	Arandela	
	39	8000 89261	2	Vite	Screw	Vis	Schraube	Tornillo	
H	40	8000 81164	2	Anello OR	O-Ring	Bague OR	O-Ring	Anillo OR	
	41	8000 97613	2	Kit registro	Adjusting kit	Groupe de réglage	Registergruppe	Grupo registro	
	42	8000 97610	1	Pistone DX compl.	R.H. piston assy.	Piston D. compl.	Kolben R. kpl	Pistón der. compl.	
	43	8000 97609	1	Pistone SX compl.	L.H. piston assy.	Piston G. compl.	Kolben L. kpl	Pistón iz. compl.	
	44	8000 97612	1	Gruppo pompante DX compl.	R.H. Damping element compl.	Amortissement D. compl.	R. Schwingungsdämpfer Kpl.	Bombeadora der. compl.	
	45	8000 97611	1	Gruppo pompante SX compl.	L.H. Damping element compl.	Amortissement G. compl.	L. Schwingungsdämpfer Kpl.	Bombeadora IZ. compl.	
	46	8000 69040	1	Testa di sterzo	Steering head	Tête direction	Lenkkopf	Cabezal de dirección	
	47	8000 69041	1	Base di sterzo con perno	Steering crown with pin	Socle de direction avec pivot	Gabelbrücke mit Bolzen	Base de dirección con perno	
	48	8000 83395	1	Ghiera registro cuscinetti	Ring nut	Embout	Nutmutter	Virol	

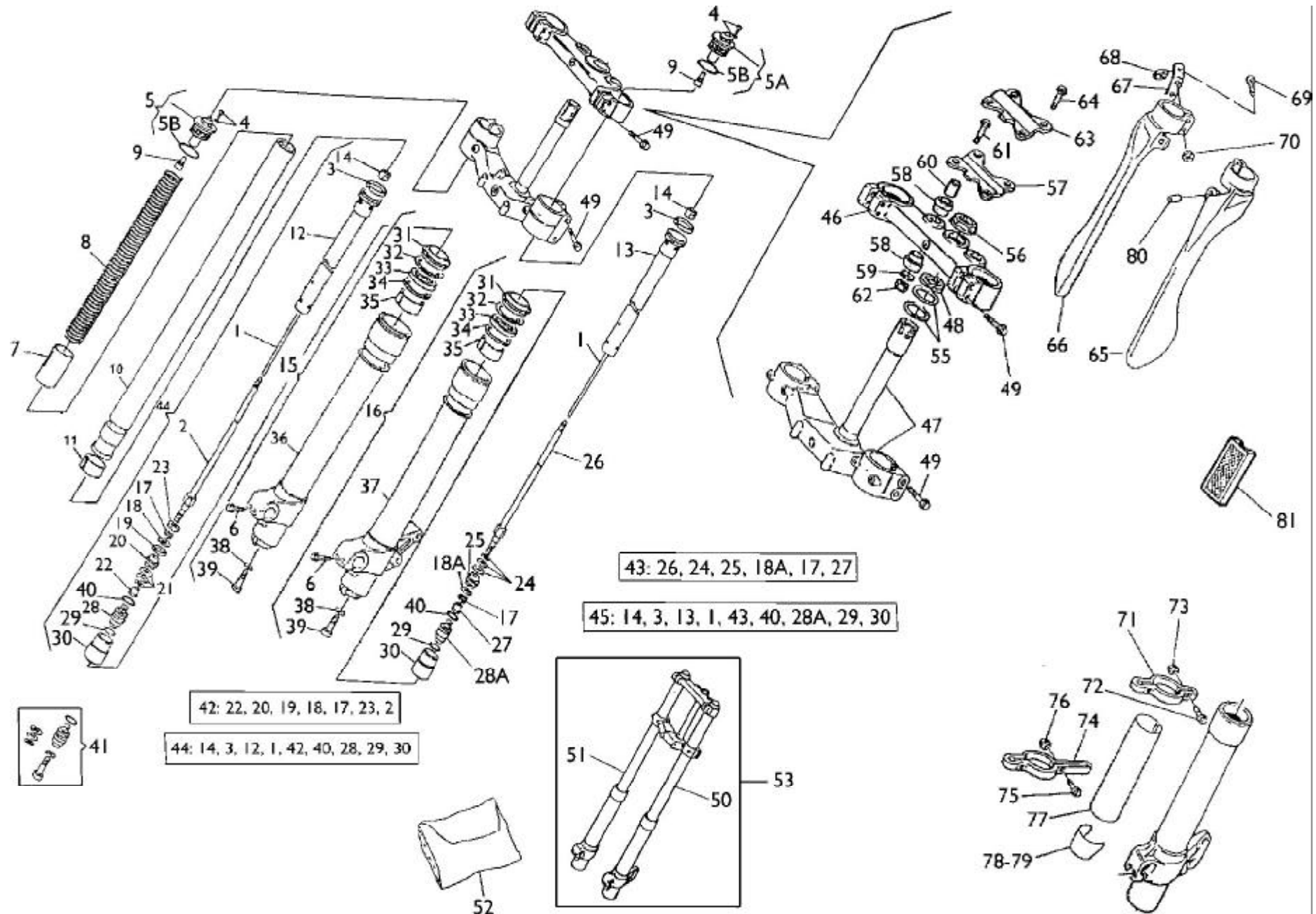

Note Notes Notas	Pos. No. N. Index Pos.	N. Cod. Code No. Nr. Code Code Nr N. Cod.	Q.tà Q.te M.ge C.ad	DENOMINAZIONE	NAME	DESIGNATION	BESHREIBUNG	DENOMINACION	Validità Validity Validité Gültig Validez
	49	8A00 69056	8	Vite (M8x45mm)	Screw (M8x45mm)	Vis (M8x45mm)	Schraube (M8x45mm)	Tornillo (M8x45mm)	
SS	50	8A00 94601	1	Stelo Sx. compl.	L.H. slider assy	Montant G. compl.	Bein, Kpl. L.	Deslizable izrda. compl.	
TT	50	8000 94601	1	Stelo Sx. compl.	L.H. slider assy	Montant G. compl.	Bein, Kpl. L.	Deslizable izrda. compl.	
SS	51	8A00 94602	1	Stelo Dx. compl.	R.H. slider assy	Montant D. compl.	Bein, Kpl. R.	Deslizable der. compl.	
TT	51	8000 94602	1	Stelo Dx. compl.	R.H. slider assy	Montant D. compl.	Bein, Kpl. R.	Deslizable der. compl.	
	52	8000 89266	1	Gruppo guarnizioni	Gasket set	Groupe garnitures	Dichtungssatz	Grupo juntas	
SS	53	8A00 94604	1	Ass. sospensione ant.	Front fork assembly	Suspension avant	Vorderteleskopegabel	Suspensión delantera compl.	
TT	53	8000 94604	1	Ass. sospensione ant.	Front fork assembly	Suspension avant	Vorderteleskopegabel	Suspensión delantera compl.	
	55	8A00 65503	2	Rosetta	Washer	Rondelle	Scheibe	Arandela	
	56	8000 69315	1	Dado	Nut	Ecrou	Mutter	Tuerca	
	57	8A00 86499	1	Morsetto inferiore	Hub	Moveau	Radnabe	Cubo	
	58	8000 60233	4	Gommino	Rubber pad	Pièce caoutchouc	Gummstück	Junta de goma	
	59	8000 60234	2	Rosetta piana	Washer	Rondelle	Scheibe	Arandela	
	60	8A00 53155	2	Distanziale	Spacer	Entretoise	Distanzstück	Separador	
	61	60N1 01220	2	Vite (M10x70 mm)	Screw (M10x70 mm)	Vis (M10x70 mm)	Schraube (M10x70 mm)	Tornillo (M10x70 mm)	
	62	8000 61314	2	Dado	Nut	Ecrou	Mutter	Tuerca	
	63	8A00 86498	2	Morsetto superiore	Hub	Moveau	Radnabe	Cubo	
	64	8C00 69056	4	Vite (M8x30 mm)	Screw (M8x30 mm)	Vis (M8x30 mm)	Schraube (M8x30 mm)	Tornillo(M8x30 mm)	
	65	80A0 83768	1	Parastelo Sx. (codice colore E)	Guard, L.H. (color code E)	Protection D. (code couleur E)	Schutz L. (Code Farbe E)	Protección izq. (còdigo colòr E)	
	65	80E0 83768	1	Parastelo Sx. (codice colore F)	Guard, L.H. (color code F)	Protection D. (code couleur F)	Schutz L. (Code Farbe F)	Protección izq. (còdigo colòr F)	
	66	80A0 83767	1	Parastelo Dx. (codice colore E)	Guard, R.H. (color code E)	Protection G. (code couleur E)	Schutz R. (Code Farbe E)	Protección der. (còdigo colòr E)	
	66	80E0 83767	1	Parastelo Dx. (codice colore F)	Guard, R.H. (color code F)	Protection G. (code couleur F)	Schutz R. (Code Farbe F)	Protección der. (còdigo colòr F)	
	67	8000 87968	1	Piastrina	Plate	Plaque	Plättchen	Placa	
	68	8000 61068	1	Molletta	Spring	Ressort	Feder	Resorte	
	69	8C00 67997	4	Vite	Screw	Vis	Schraube	Tornillo	
	70	61N4 15192	4	Dado	Nut	Ecrou	Mutter	Tuerca	
	71	8000 79623	1	Anello	Ring	Bague	Ring	Anillo	
	72	60N4 02489	1	Vite	Screw	Vis	Schraube	Tornillo	
	73	61N4 15192	1	Dado	Nut	Ecrou	Mutter	Tuerca	

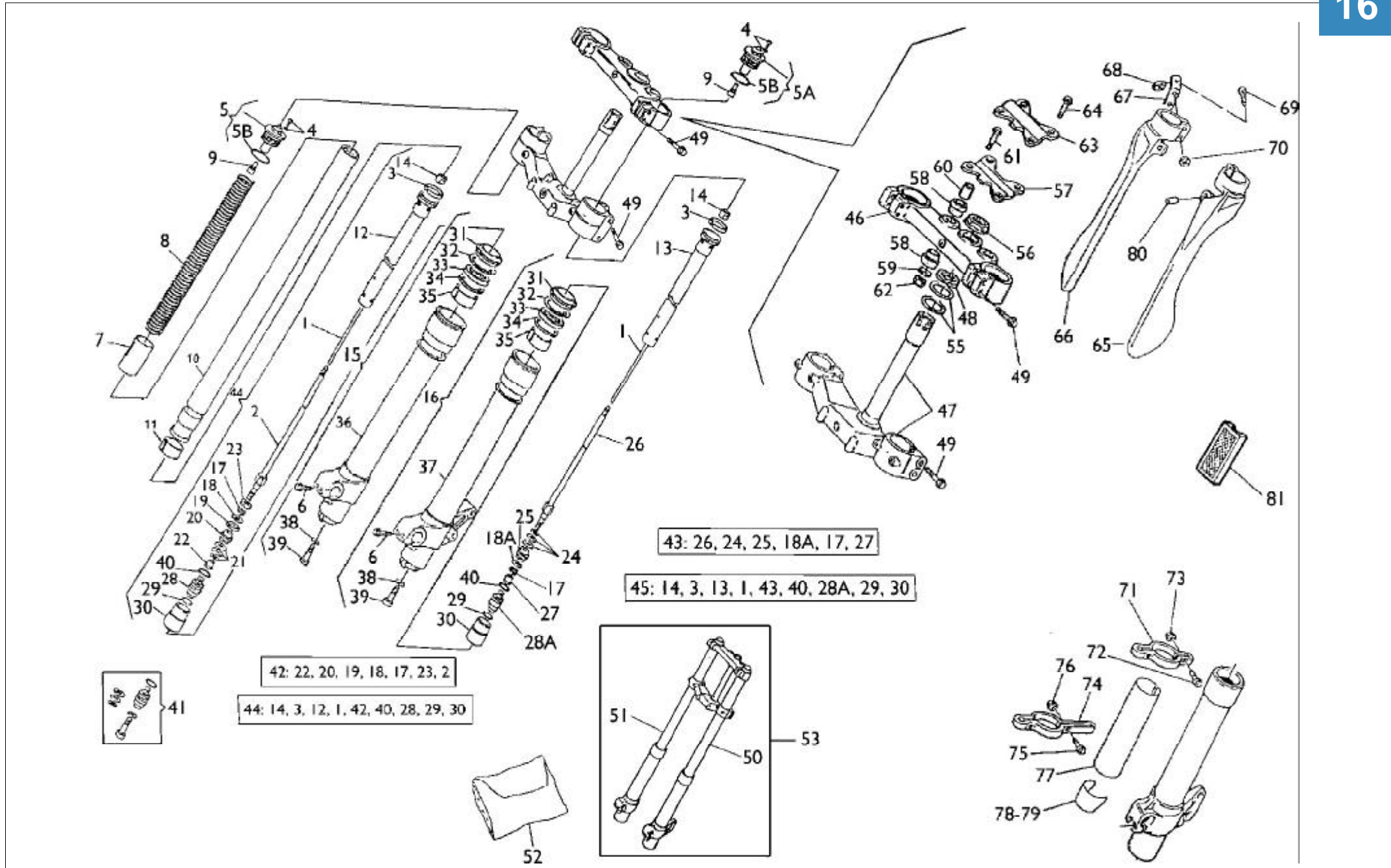



Note Notes Marke Notas	Pos. No. N. Index Pos.	N. Cod. Code No. Nr. Code Code Nr N. Cod.	Q.tà Q.ty Q.te M.ge C.ad	DENOMINAZIONE	NAME	DESIGNATION	BESHREIBUNG	DENOMINACION	Validità Validity Validité Gültig Validez
	74	8000 83794	1	Anello	Ring	Bague	Ring	Anillo	
	75	8B00 67997	2	Vite	Screw	Vis	Schraube	Tornillo	
	76	61N4 15192	2	Dado	Nut	Ecrou	Mutter	Tuerca	
	77	8000 90666	2	Adesivo superiore	Trim	Décal.	Abziehbild	Calcomania	
	78	8000 90664	1	Adesivo inferiore Sx.	Trim	Décal.	Abziehbild	Calcomania	
	79	8000 90665	1	Adesivo inferiore Dx.	Trim	Décal.	Abziehbild	Calcomania	
	80	8C00 70034	2	Distanziale	Spacer	Entretoise	Distanzstück	Separador	
	81	8000 74842	2	Catadiottro (AUS, USA)	Reflector (AUS, USA)	Catadioptrique (AUS, USA)	Rückstrahler (AUS, USA)	Catafaros (AUS, USA)	
H				Per ricambi sono forniti anche in gruppo pos. 52	Gasket are also supplied in bag ref. N° 52	Pièces de rechange sont fournies en unités pos. 52	Die Dichtungen sind auch im Umschlag Bez. Nr. 52	Partes de recambio es provisto en grupo pos. 52	

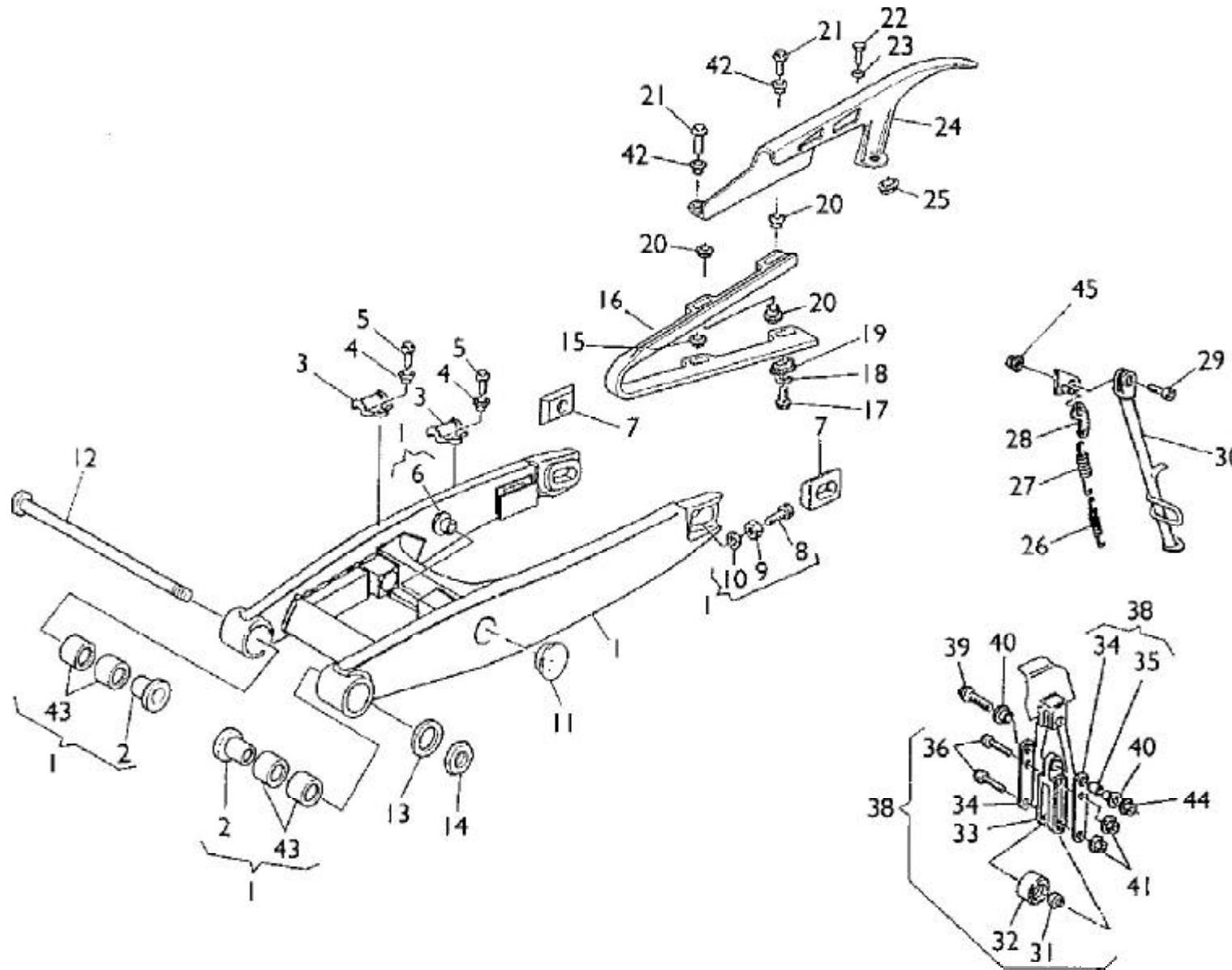

Note Notes Notas	Pos. No. N. Index Pos.	N. Cod. Code No. Nr. Code Code Nr N. Cod.	Q.tà Q.ty Q.te M.ge C.ad	DENOMINAZIONE	NAME	DESIGNATION	BESHREIBUNG	DENOMINACION	Validità Validity Validité Gültig Validez
	1	8000 85221	1	Forcellone completo	Swing arm assy.	Fourche complete	Gabel, Kpl.	Horquilla compl.	
	2	8000 83904	2	Bussola	Bushing	Douille	Buchse	Manguito	
	3	80A0 73456	2	Guidacavo	Cable guide	Guide câble	Kabelführung	Gu+a-cable	
	4	8000 69282	2	Bussola	Bushing	Douille	Buchse	Manguito	
	5	8000 20536	2	Vite	Screw	Vis	Schraube	Tornillo	
	6	8B00 42029	2	Bussola	Bushing	Douille	Buchse	Manguito	
	7	8000 71624	1	Tendicatena lato dado (DX)	Chain adjuster - nut side (R.H.)	Tend. de chaine côtés ecrou(D.)	Kettenspanner Mutterseite (R.)	Tensor de cadena lato tuerca (DER.)	
	7	8000 71625	1	Tendicatena lato perno (SX)	Chain adjuster - pin side (L.H.)	Tend. de chaine côtés pivot (G.)	Kettenspanner bolzenseite (L.)	Tensor de cadena lato perno (IZ.)	
	8	8C00 61121	2	Vite	Screw	Vis	Schraube	Tornillo	
	9	8000 17810	2	Dado	Nut	Ecrou	Mutter	Tuerca	
	10	8000 08536	2	Rosetta	Washer	Rondelle	Scheibe	Arandela	
	11	80A0 74388	2	Tappo	Plug	Bouchon	Verschluss	Tapón	
	12	8000 71620	1	Perno forcellone	Fork pin	Pivot fourche	Gabelbolzen	Perno horquilla	
	13	8000 32388	1	Rosetta piana	Washer	Rondelle	Scheibe	Arandela	
	14	8000 71623	1	Dado	Nut	Ecrou	Mutter	Tuerca	
	15	8000 75166	2	Scodellino	Cup	Cuvette	Teller	Cubeta	
	16	8000 72884	1	Pattino catena	Chain slider	Glissière	Gleitbahn	Plato cadena	
	17	8000 67997	2	Vite	Screw	Vis	Schraube	Tornillo	
	18	8000 36137	2	Rosetta	Washer	Rondelle	Scheibe	Arandela	
	19	8000 59289	1	Scodellino	Cup	Cuvette	Teller	Cubeta	
	20	8000 75166	3	Scodellino	Cup	Cuvette	Teller	Cubeta	
	21	8C00 67997	2	Vite (M5x20mm)	Screw (M5x20mm)	Vis (M5x20mm)	Schraube (M5x20mm)	Tornillo (M5x20mm)	
	22	8000 20536	1	Vite	Screw	Vis	Schraube	Tornillo	
	23	8000 36137	1	Rosetta	Washer	Rondelle	Scheibe	Arandela	
	24	8AA0 76028	1	Copricatena (codice colore E)	Chain guard (color code E)	Carter de chaine (code couleur E)	Kettenkasten (Code Farbe E)	Cubre-cadena (còdigo colòr E)	
	24	8AB0 76028	1	Copricatena (codice colore F)	Chain guard (color code F)	Carter de chaine (code couleur F)	Kettenkasten (Code Farbe F)	Cubre-cadena (còdigo colòr F)	
	25	8000 59289	1	Scodellino	Cup	Cuvette	Teller	Cubeta	
	26	8000 62676	1	Molla interna	Spring	Ressort	Feder	Resorte	
	27	8000 62675	1	Molla esterna	Spring	Ressort	Feder	Resorte	

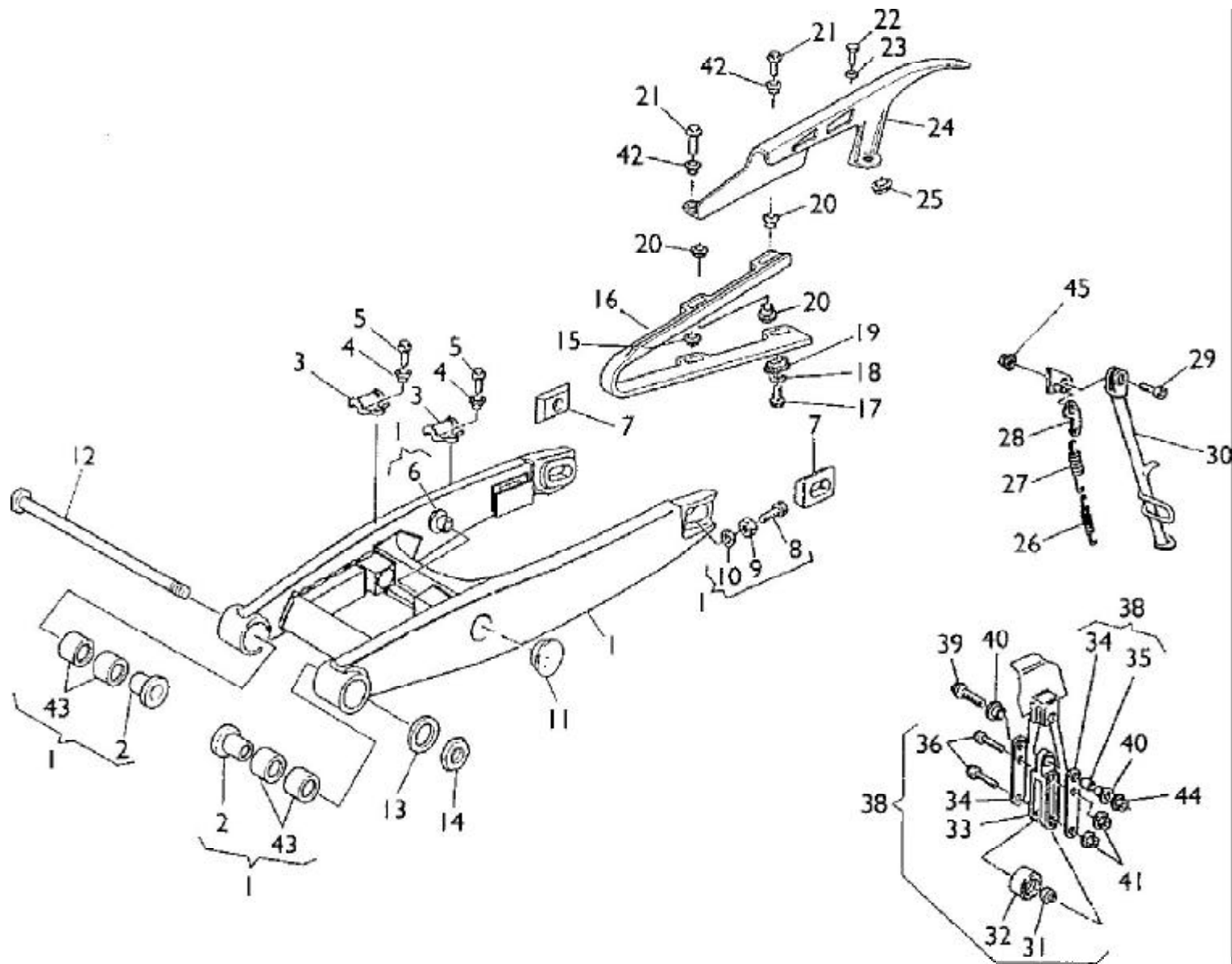

Note Notes Notas	Pos. No. N. Index Pos.	N. Cod. Code No. Nr. Code Code Nr N. Cod.	Q.tà Q.ty Q.te M.ge C.ad	DENOMINAZIONE	NAME	DESIGNATION	BESHREIBUNG	DENOMINACION	Validità Validity Validité Gültig Validez
	28	8000 62644	1	Piastrina	Plate	Plaquette	Plättchen	Placa	
	29	8A00 97976	1	Vite	Screw	Vis	Schraube	Tornillo	
SS	30	8DA0 87179	1	Gamba laterale	Side stand	Bequille lat.	Seitenständer	Horquilla lateral	
TT	30	8CA0 87179	1	Gamba laterale	Side stand	Bequille lat.	Seitenständer	Horquilla lateral	
	31	8A00 20182	1	Distanziale	Spacer	Entretoise	Distanzstück	Separador	
	32	1511 31701	1	Rullo guidacatena	Roller	Aiguille	Rolle	Rodillo	
	33	8000 72874	1	Staffa guidacatena	Plate	Plaque	Platte	Placa	
	34	8000 76002	2	Lamiera guidacatena	Chain guide	Guide-chaine	Kettenführung	Guía-cadena	
	35	8A00 36984	1	Bussola	Bushing	Douille	Buchse	Manguito	
	36	8E00 67545	2	Vite (M6x40mm)	Screw (M6x40mm)	Vis (M6x40mm)	Schraube (M6x40mm)	Tornillo (M6x40mm)	
	38	8000 76003	1	Guidacatena	Chain guide	Guide-Chaine	Kettenführung	Guía-cadena	
	39	8000 62795	1	Vite (M8x50mm)	Screw (M8x50mm)	Vis (M8x50mm)	Schraube (M8x50mm)	Tornillo (M8x50mm)	
	40	8A00 66661	2	Bussola	Bushing	Douille	Buchse	Manguito	
	41	8000 61313	2	Dado	Nut	Ecrou	Mutter	Tuerca	
	42	8A00 69282	2	Bussola	Bushing	Douille	Buchse	Manguito	
	43	8000 76283	4	Gabbia a rulli (ø22xø28x18mm)	Needle cage (ø22xø28x18mm)	Cage à aiguilles (ø22xø28x18mm)	Nadelkaefig (ø22xø28x18mm)	Jaula de agujas del cojinete (ø22xø28x18mm)	
	44	8000 40720	1	Dado	Nut	Ecrou	Mutter	Tuerca	
	45	8000 41513	1	Dado	Nut	Ecrou	Mutter	Tuerca	

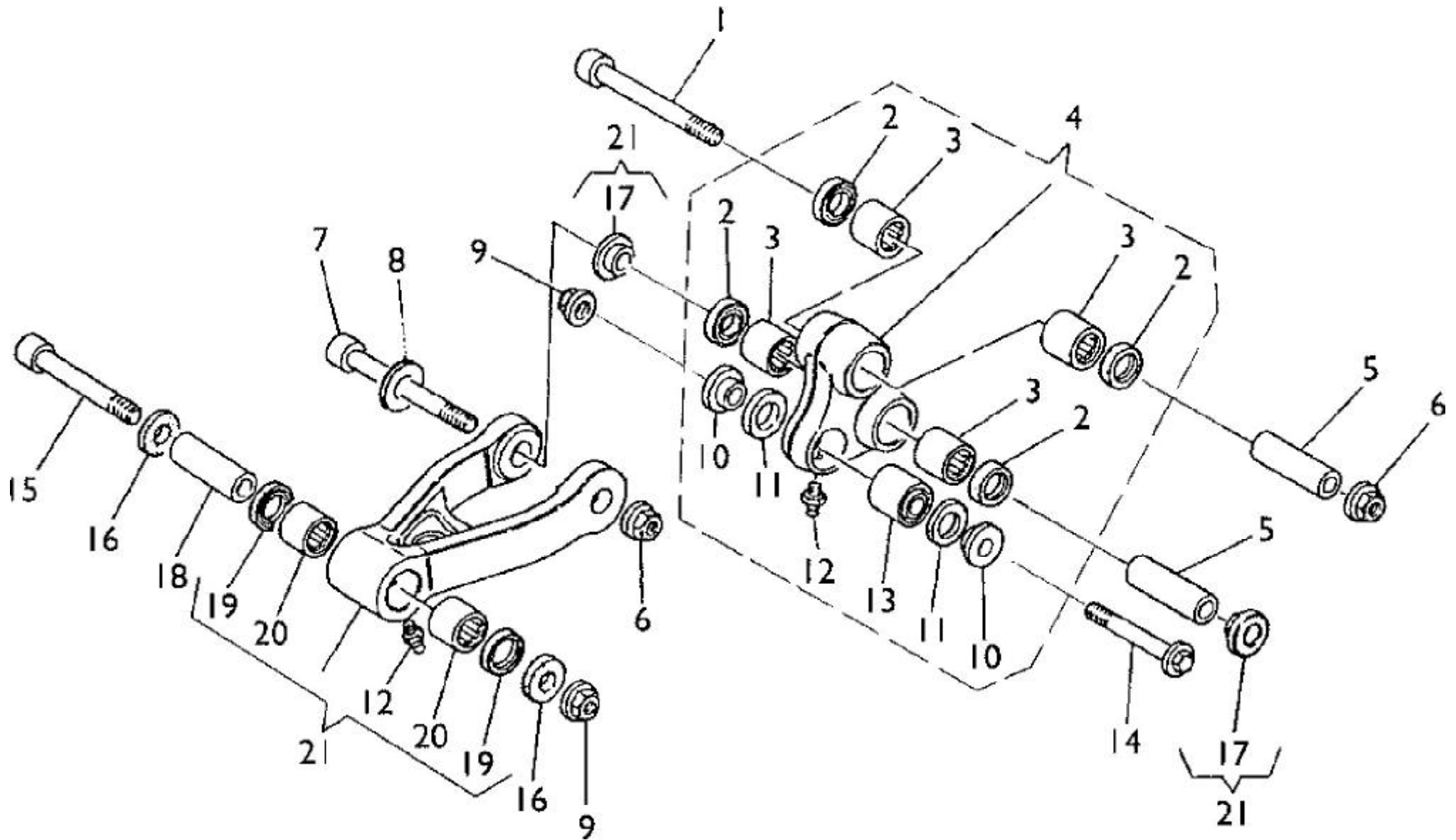

Note Notes Notas	Pos. No. N. Index Pos.	N. Cod. Code No. Nr. Code Code Nr N. Cod.	Q.tà Q.ty Q.te M.ge C.ad	DENOMINAZIONE	NAME	DESIGNATION	BESHREIBUNG	DENOMINACION	Validità Validity Validité Gültig Validez
	1	8000 74372	1	Vite (M12x100mm)	Screw (M12x100mm)	Vis (M12x100mm)	Schraube (M12x100mm)	Tornillo (M12x100mm)	
	2	8000 32065	4	Anello di tenuta (ø20xø26x4mm)	Seal Ring (ø20xø26x4mm)	Bague de retenue (ø20xø26x4mm)	Dichtring (ø20xø26x4mm)	Anillo de retención (ø20xø26x4mm)	
	3	8000 42781	4	Cuscinetto (ø20xø26x20mm)	Bearing (ø20xø26x20mm)	Roulement (ø20xø26x20mm)	Lager (ø20xø26x20mm)	Cojinete (ø20xø26x20mm)	
	4	8000 75868	1	Bilanciere	Rocking lever	Balancier	Schwinge	Balancines	
	5	8A00 75153	2	Spinotto	Gudgeon	Axe	Bolzen	Perno	
	6	8000 42023	2	Dado	Nut	Ecrou	Mutter	Tuerca	
	7	8000 77413	1	Vite (M12x100mm)	Screw (M12x100mm)	Vis (M12x100mm)	Schraube (M12x100mm)	Tornillo (M12x100mm)	
	8	8AA0 36237	1	Rosetta	Washer	Rondelle	Scheibe	Arandela	
	9	8000 42022	2	Dado	Nut	Ecrou	Mutter	Tuerca	
	10	1511 33302	2	Bussola	Bushing	Douille	Buchse	Manguito	
	11	8000 38767	2	Guarnizione	Gasket	Garniture	Dichtung	Junta	
	12	8000 01412	2	Ingrassatore	Lubricator	Graisseur	Schmierbüchse	Lubricador	
	13	8000 72168	1	Cuscinetto sferico (ø12xø26x16mm)	Bearing (ø12xø26x16mm)	Roulement (ø12xø26x16mm)	Lager (ø12xø26x16mm)	Cojinete (ø12xø26x16mm)	
	14	8A00 62797	1	Vite (M10x50mm)	Screw (M10x50mm)	Vis (M10x50mm)	Schraube (M10x50mm)	Tornillo (M10x50mm)	
	15	8A00 69138	1	Vite (M10x75mm)	Screw (M10x75mm)	Vis (M10x75mm)	Schraube (M10x75mm)	Tornillo (M10x75mm)	
	16	8000 73394	2	Anello di feltro	Feltseal	Bague en fetre	Filzring	Anillo de fieltro	
	17	8B00 42029	2	Bussola	Bushing	Douille	Buchse	Manguito	
	18	8000 59839	1	Spinotto	Gudgeon	Axe	Bolzen	Perno	
	19	8000 38957	2	Anello di tenuta (ø18xø24x4mm)	Seal Ring (ø18xø24x4mm)	Bague de retenue (ø18xø24x4mm)	Dichtring (ø18xø24x4mm)	Anillo de retención (ø18xø24x4mm)	
	20	8000 38956	2	Cuscinetto (ø18xø24x16mm)	Bearing (ø18xø24x16mm)	Roulement (ø18xø24x16mm)	Lager (ø18xø24x16mm)	Cojinete (ø18xø24x16mm)	
	21	8B00 69285	1	Tirante orizzontale	Tie rod	Tirant	Spannstange	Tirante	

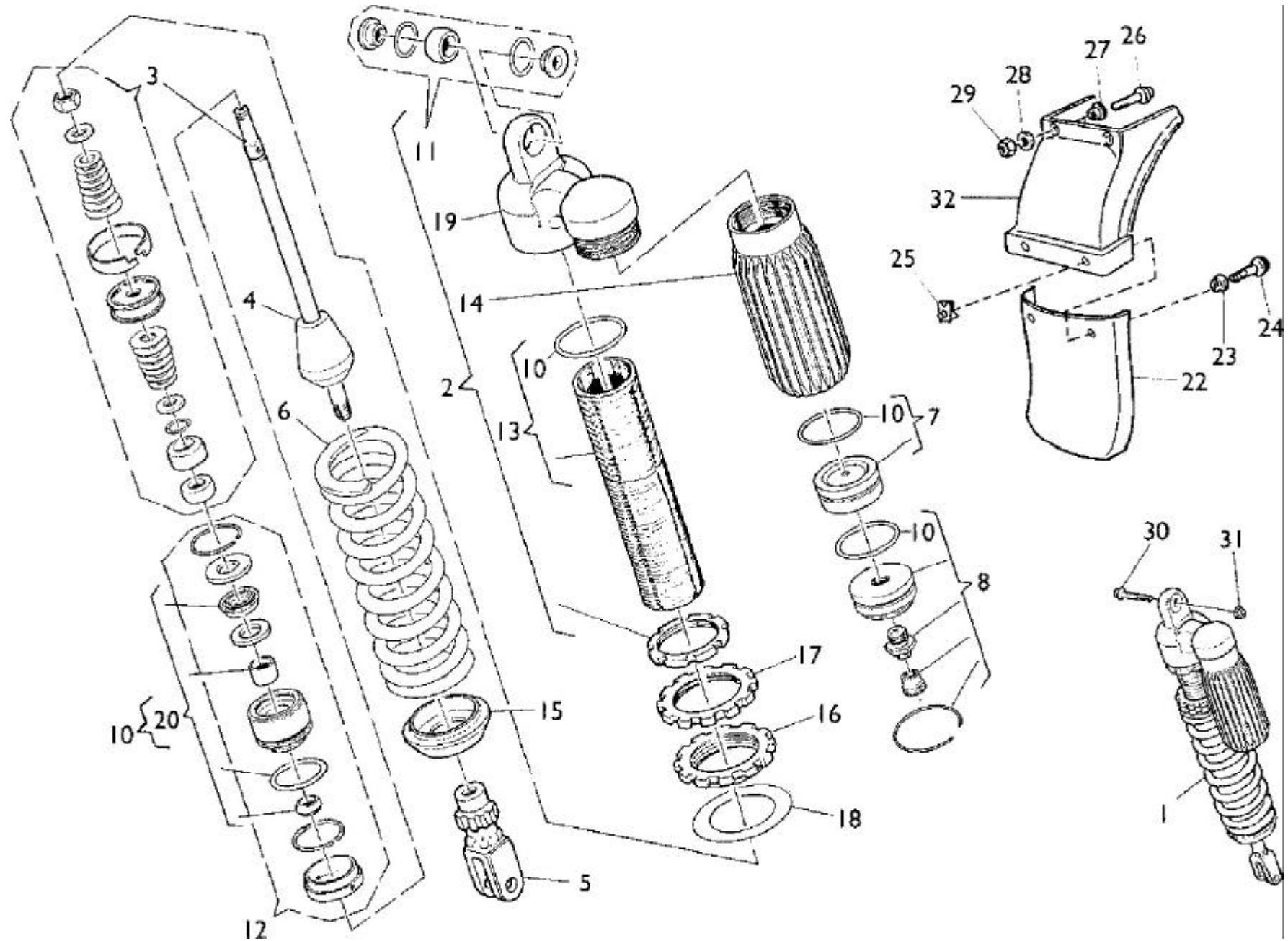

Note Notes Notas	Pos. No. Index Pos.	N. Cod. Code No. Nr. Code Code Nr N. Cod.	Q.tà Q.ty Q.te M.ge C.ad	DENOMINAZIONE	NAME	DESIGNATION	BESHREIBUNG	DENOMINACION	Validità Validity Validité Gültig Validez
	1	8000 94605	1	Ammortizzatore completo	Shock-absorber	Ammortisseur	Stossdampfer	Amortigüador	
	2	8000 95887	1	Gruppo corpo	Damper case assy	Groupe corps amortisseur	Stossdämpferkörper Kpl.	Corpo amortiguador compl.	
	3	8000 95888	1	Gruppo stelo	Rod assy	Groupe tige	Pumpenstuckgruppe	Grupo espiga	
	4	8000 91853	1	Tampone	Pad	Tampon	Stopfen	Tampón	
	5	8000 95889	1	Gruppo forcella	Fork assy	Groupe fourche	Gabelgruppe Kpl.	Grupo horquilla	
	6	80A0 79083	1	Molla(k=8 Kg/mm)	Spring (k=8 Kg/mm)	Ressort (k=8 Kg/mm)	Feder (k=8 Kg/mm)	Resorte (k=8 Kg/mm)	
	7	8000 89085	1	Diaframma	Diaphragm	Diaphragme	Biegeplatte	Diafragma	
	8	8000 89086	1	Gruppo serbatoio	Tank assy	Groupe reservoir	Tankgruppe Kpl.	Grupo deposito compl.	
	10	8000 95891	1	Gruppo guarnizioni	Gasket set	Groupe garnitures	Dichtungssatz	Grupo juntas	
	11	8000 91856	1	Gruppo snodo	Ball joint assy	Groupe joint a rotule	Kugelgelenkgruppe Kpl.	Grupo articulaciön esférica	
	12	8000 95892	1	Gruppo guida stelo	Guide rod assy	Groupe guide tige	Pumpenst•ckf•hrunggruppe	Grupo guja espiga	
	13	8000 95893	1	Corpo ammortizzatore	Damper case	Corps amortisseur	Stossdämpferkörper	Corpo amortig•ador	
	14	8000 91859	1	Serbatoio	Tank	Reservoir	Tank	Deposito	
	15	8000 89096	1	Fondello	Bottom	Fond	Bodenscheibe	Casquillo	
	16	8000 89097	1	Ghiera	Ring nut	Embout	Nutmutter	Virola	
	17	8000 89098	1	Ghiera	Ring nut	Embout	Nutmutter	Virola	
	18	8000 89099	1	Rosetta per molla	Washer	Rondelle	Scheibe	Arandela	
	19	8000 91860	1	Supporto serbatoio	Tank support	Support reservoir	Gastankhalterung	Soporte deposito	
	20	8000 95894	1	Gruppo guarnizioni per stelo	Rod gasket set	Jeu joints pour tige	Dichtungssatz für Pumpenstock	Serie juntas por espiga	
	22	80A0 69551	1	Protezione ammortizzatore	Guard	Protection	Schutz	Protección	
	23	8A00 69429	2	Bussola	Bushing	Douille	Buchse	Manguito	
	24	8000 62728	2	Vite	Screw	Vis	Schraube	Tornillo	
	25	8000 46893	2	Dado a graffetta	Nut	Ecrou	Mutter	Tuerca	
	26	8A00 67545	2	Vite	Screw	Vis	Schraube	Tornillo	
	27	8000 72268	2	Distanziale	Spacer	Entretoise	Distanzstück	Separador	
	28	8000 56359	2	Rosetta piana	Washer	Rondelle	Scheibe	Arandela	
	29	8000 44240	2	Dado	Nut	Ecrou	Mutter	Tuerca	
	30	8A00 62797	1	Vite (M10x50 mm)	Screw (M10x50 mm)	Vis (M10x50 mm)	Schraube (M10x50 mm)	Tornillo (M10x50 mm)	
	31	8000 42022	1	Dado	Nut	Ecrou	Mutter	Tuerca	
	32	8000 84501	1	Tegolo	Mudguard	Garde-boue	Kotflügel	Guarda-Barros	

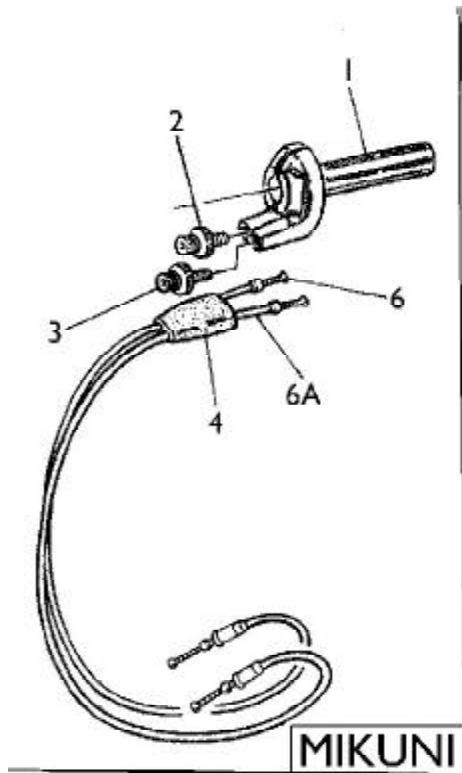

MIKUNI

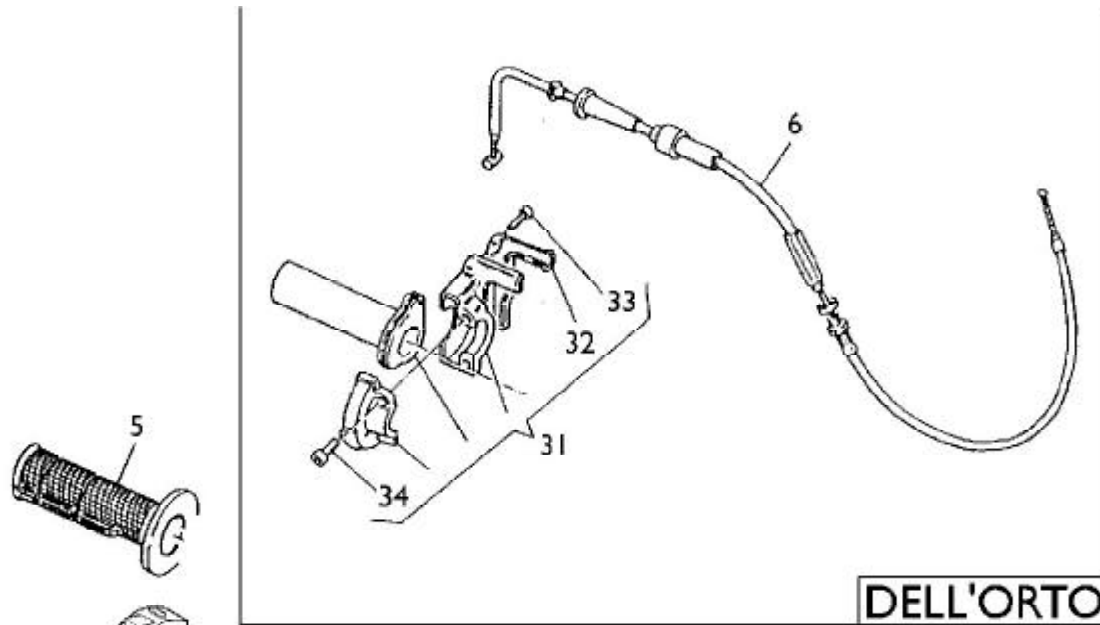

DELL'ORTO

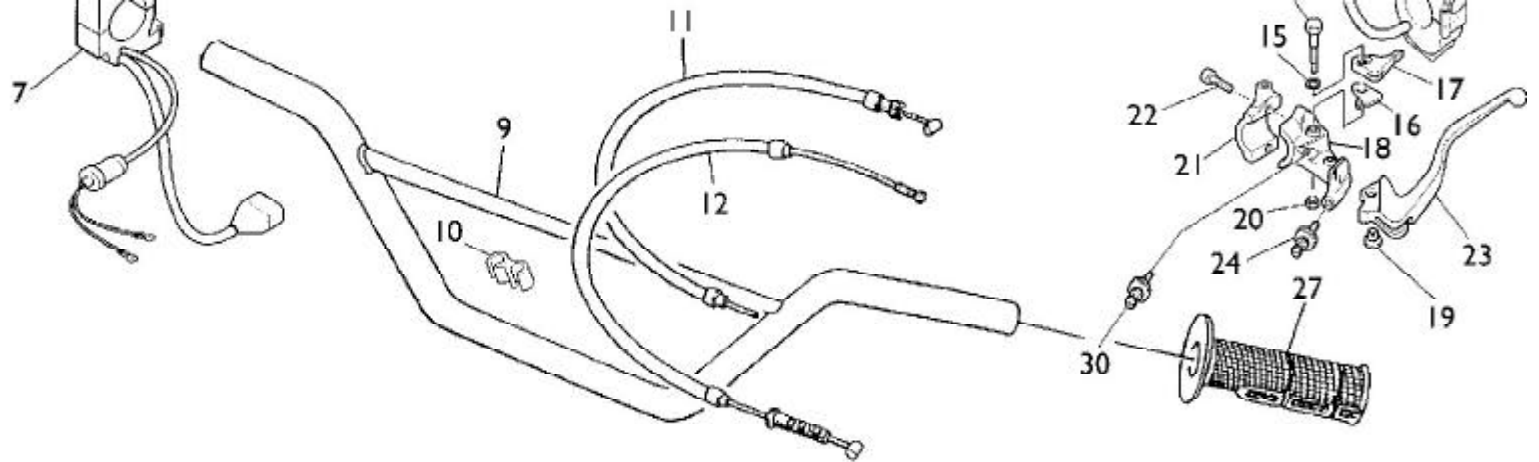

13: 14+21, 23, 24

Note Notes Notas	Pos. No. N. Index Pos.	N. Cod. Code No. Nr. Code Code Nr N. Cod.	Q.tà Q.ty Q.te M.ge C.ad	DENOMINAZIONE	NAME	DESIGNATION	BESHREIBUNG	DENOMINACION	Validità Validity Validité Gültig Validez
SS	1	8000 99580	1	Comando gas completo (#)	Throttle control compl. (#)	Commande gaz compl. (#)	Gasgriff kpl. (#)	Accionam. aceler. compl. (#)	
SS	2	8000 66775	1	Gruppo registro (M8) (#)	Adjuster set (M8) (#)	Groupe réglage (M8) (#)	Kupplungsregler (M8) (#)	Grupo regul. (M8) (#)	
SS	3	8000 78688	1	Gruppo registro (M6) (#)	Adjuster set (M6) (#)	Groupe réglage (M6) (#)	Kupplungsregler (M6) (#)	Grupo regul. (M6) (#)	
SS	4	8000 99581	1	Cappuccio (#)	Cap kit (#)	Kit capuchon (#)	Kappe Gruppe (#)	Kit capuchón (#)	
	5	8000 76688	1	Manopola Dx.	R.H. grip	Poignée G.	Griff R.	Manopla der.	
SS	6	8000 99183	1	Trasm. com. gas (mandata) (#)	Throttle wire (#)	Fil comm. gaz (#)	Gassteuerung kabel (#)	Tran. acelerador (#)	
TT	6	8000 75842	1	Trasm. com. gas (mandata) (§)	Throttle wire (§)	Fil comm. gaz (§)	Gassteuerung kabel (§)	Tran. acelerador (§)	
USA	6	8000 75842	1	Trasm. com. gas (mandata) (§)	Throttle wire (§)	Fil comm. gaz (§)	Gassteuerung kabel (§)	Tran. acelerador (§)	
SS	6A	8A00 99183	1	Trasm. com. gas (ritorno) (#)	Throttle wire (#)	Fil comm. gaz (#)	Gassteuerung kabel (#)	Tran. acelerador (#)	
	7	8000 90584	1	Commutatore Dx.	R.H. switch	Commutateur	Kombischalter	Conmutador	
	9	8A00 92301	1	Manubrio	Hanblebar	Guidon	Lenker	Manillar	
	10	8000 88597	1	Guida trasmissione frizione	Guide	Guide	Führung	Guia	
SS	11	8A00 78681	1	Trasmissione starter (#)	Starter wire (#)	Trasm. comm. starter (#)	Anlassen Kabel (#)	Transm. mando starter (#)	
TT	11	8000 89119	1	Trasmissione starter (§)	Starter wire (§)	Trasm. comm. starter (§)	Anlassen Kabel (§)	Transm. mando starter (§)	
USA	11	8000 89119	1	Trasmissione starter (§)	Starter wire (§)	Trasm. comm. starter (§)	Anlassen Kabel (§)	Transm. mando starter (§)	
	12	8000 89124	1	Trasmissione comando frizione	Clutch transm.	Transm. com. embrayage	Führungssteuer. der Kupplung	Tran. mando embr. compl.	
	13	8A00 87054	1	Comando frizione compl.	Clutch control lever, assy	Levier com. embrayage compl.	Kupplungshebel, Kpl.	Palanca embrague comp.	
	14	8000 89815	1	Perno	Pin	Pivot	Bolzen	Perno	
	15	8000 47826	1	Rosetta	Washer	Rondelle	Scheibe	Arandela	
	16	8000 87276	1	Piastrina leva starter	Plate	Plaque	Platte	Placa	
	17	8000 47822	1	Leva aria (choke)	Starter control	Commande starter	Startergriff	Accionamiento arranque	
	18	8A00 88746	1	Supporto	Support	Support	Halterung	Soporte elástico	
	19	8000 89814	1	Distanziale	Spacer	Entretoise	Distanzstück	Separador	
	20	8000 61313	1	Dado	Nut	Ecrou	Mutter	Tuerca	
	21	8000 78915	1	Cavallotto	U-Bolt	Cavalier	Bügelbolzen	Caballote	
	22	8000 62729	2	Vite di fissaggio cavallotto	Screw	Vis	Schraube	Tornillo	
	23	8000 89813	1	Leva frizione	Clutch lever	Levier embrayage	Kupplungshebel	Palanca mando embrague	
	24	8000 67355	1	Gruppo registro	Adjuster set	Groupe réglage	Kupplungsreglergruppe	Grupo regul.	
	25	8A00 90583	1	Commutatore Sx.	L.H. switch	Commutateur	Kombischalter	Conmutador	
	25	8000 95249	1	Commutatore Sx. (J, USA)	L.H. switch (J, USA)	Commutateur (J, USA)	Kombischalter (J, USA)	Conmutador (J, USA)	
	27	8000 76687	1	Manopola Sx.	L.H. grip	Poignée G.	L. Griff	Manopla izrda.	
D	28	8B00 68934	1	Specchietto retrovisore Dx	R.H. driving mirror	Rétroviseur D.	Rückspiegel Rechts	Espejo retrovisor derecho	
D	29	8C00 68934	1	Specchietto retrovisore Sx	L.H. driving mirror	Rétroviseur G.	Rückspiegel Links	Espejo retrovisor izquierdo	

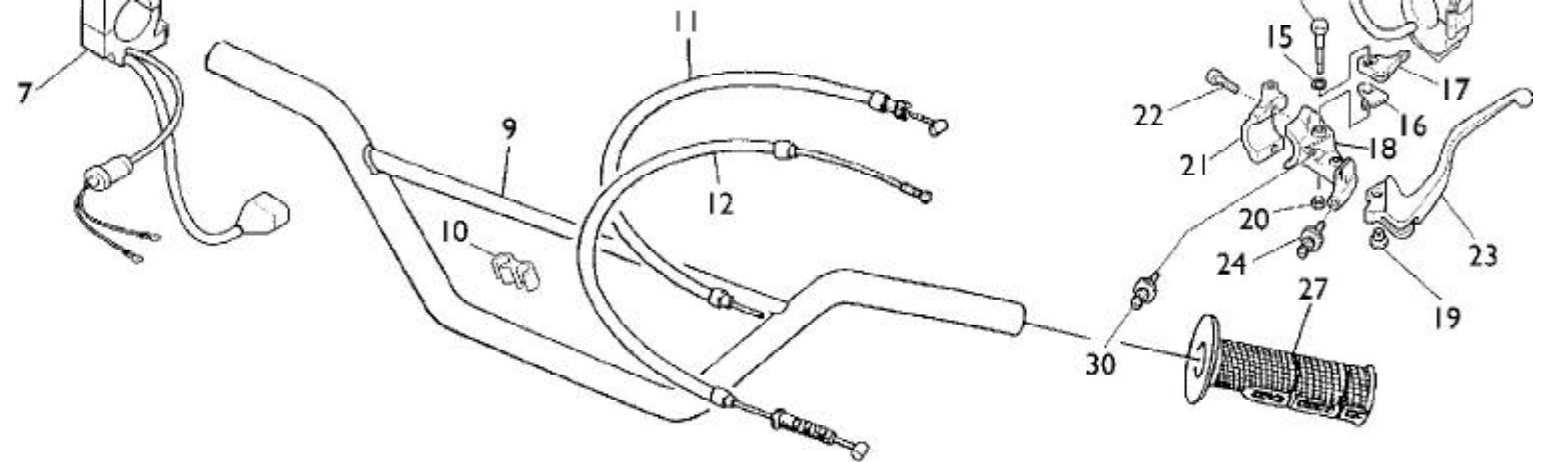
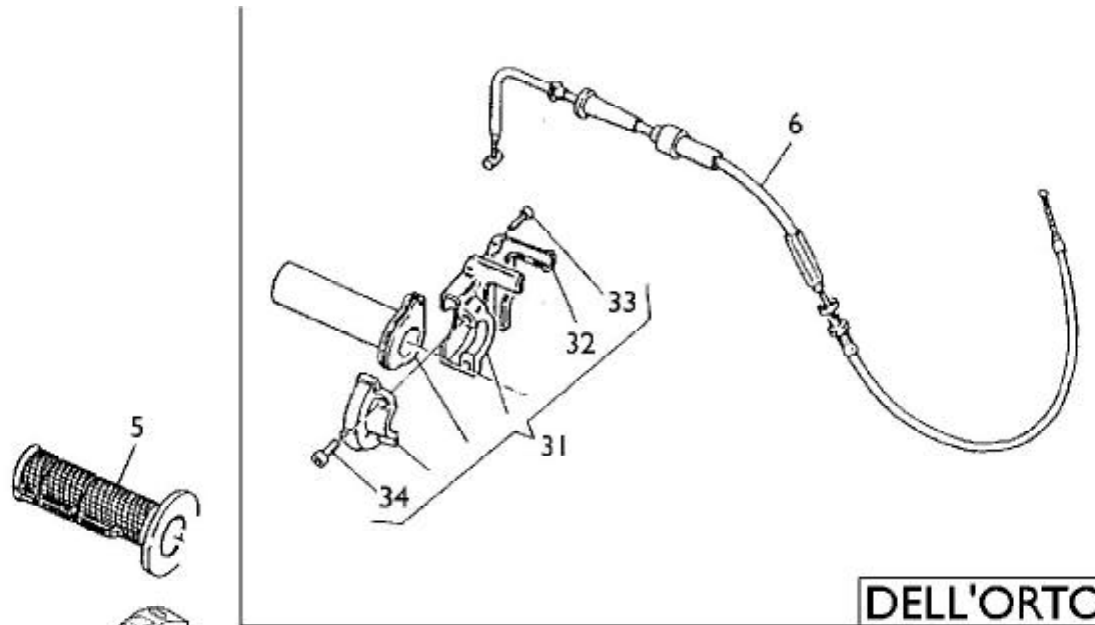
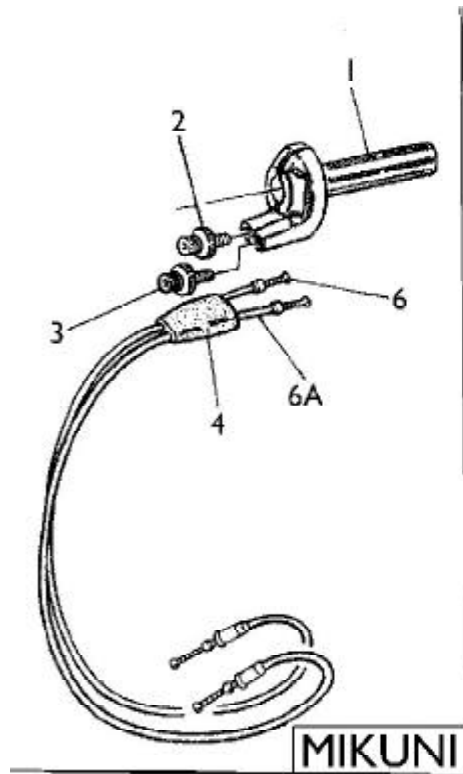

13: 14-21, 23, 24



TE E 610 dual purpose -
SMS 610 / 2004

TAVOLA
DRAWING
TABLE
BILD
TABLA

19

MANUBRIO E COMANDI - HANDLEBAR AND CONTROLS
GUIDON ET COMMANDES - LENKER UND STEUERORGANE
MANILLAR Y MANDOS

Note Notes Marka Notas	Pos. No. N. Index Pos.	N. Cod. Code No. Nr. Code Code Nr N. Cod.	Q.tà Q.ty Q.te M.ge C.ad	DENOMINAZIONE	NAME	DESIGNATION	BESHREIBUNG	DENOMINACION	Validità Validity Validité Gultig Validez
	30	8000 95248	1	Interruttore frizione	Clutch switch	Interrupteur embrayage	Kupplung schalter	Interruptor embrague	
TT	31	8000 75155	1	Comando gas completo (§)	Throttle control compl. (§)	Commande gaz compl. (§)	Gasgriff kpl. (§)	Accionam. acel. compl. (§)	
USA	31	8000 75155	1	Comando gas completo (§)	Throttle control compl. (§)	Commande gaz compl. (§)	Gasgriff kpl. (§)	Accionam. acel. compl. (§)	
TT	32	8000 75310	1	Coperchio (§)	Cover (§)	Couvercle (§)	Deckel (§)	Tapa (§)	
USA	32	8000 75310	1	Coperchio (§)	Cover (§)	Couvercle (§)	Deckel (§)	Tapa (§)	
TT	33	8000 66774	2	Vite (§)	Screw (§)	Vis (§)	Schraube (§)	Tornillo (§)	
USA	33	8000 66774	2	Vite (§)	Screw (§)	Vis (§)	Schraube (§)	Tornillo (§)	
TT	34	60N1 07330	2	Vite (§)	Screw (§)	Vis (§)	Schraube (§)	Tornillo (§)	
USA	34	60N1 07330	2	Vite (§)	Screw (§)	Vis (§)	Schraube (§)	Tornillo (§)	
(#)				carburatore "Mikuni"	"Mikuni" carburetor	Carburateur "Mikuni"	"Mikuni" Vergaser	Carburador "Mikuni"	
(§)				carburatore "Dell'Orto"	"Dell'Orto" carburetor	Carburateur "Dell'Orto"	"Dell'Orto" Vergaser	Carburador "Dell'Orto"	

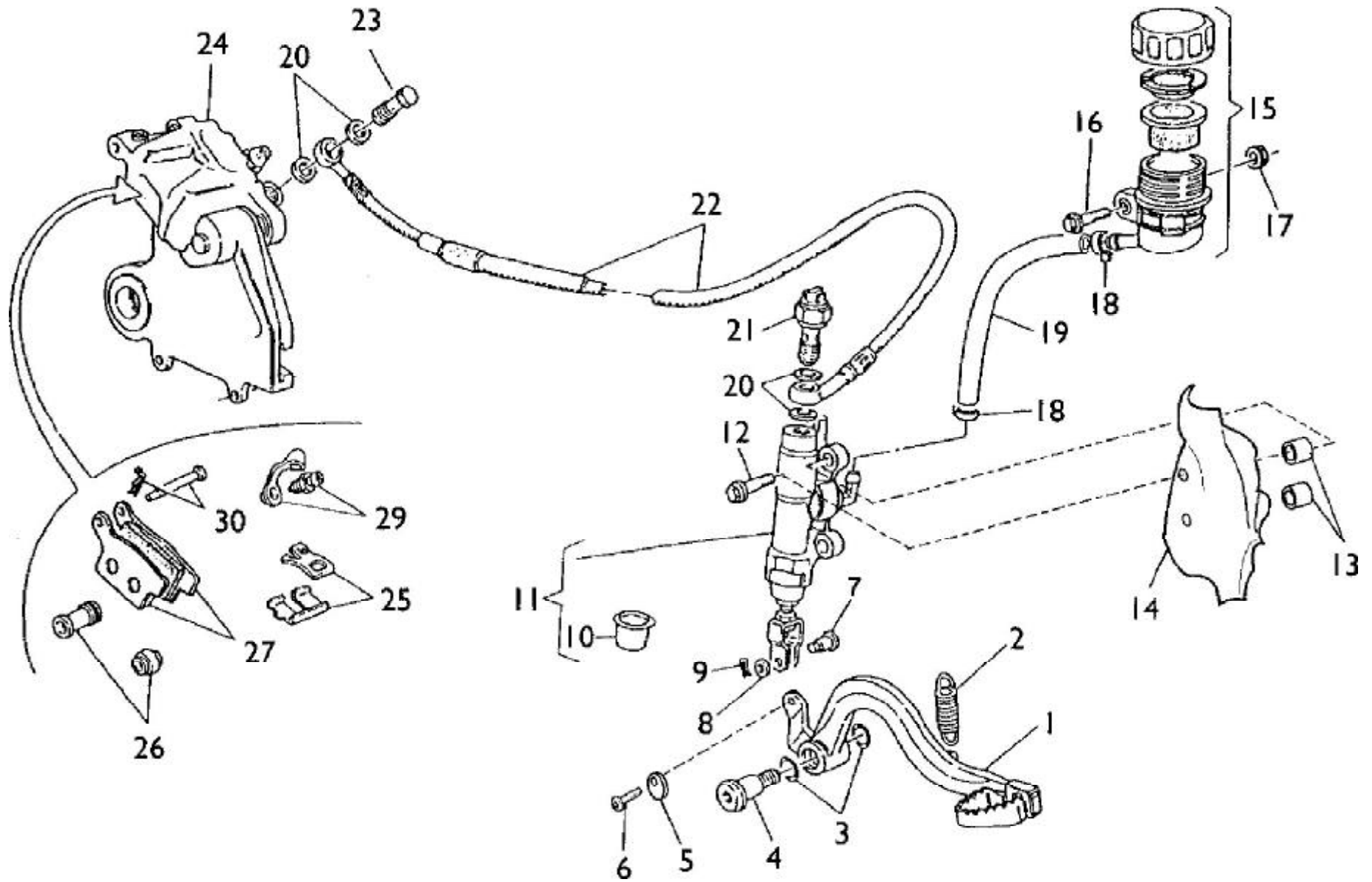

Note Notes Notes Marka Notas	Pos. No. N. Index Pos.	N. Cod. Code No. Nr. Code Code Nr N. Cod.	Q.tà Q.ty Q.te M.ge C.ad	DENOMINAZIONE	NAME	DESIGNATION	BESHREIBUNG	DENOMINACION	Validità Validity Validité Gültig Validez
	1	8000 85958	1	Pedale comando freno	Brake control pedal	Levier comm. frein	Bremshebel	Palanca accionamiento freno	
	2	8000 55903	1	Molla	Spring	Ressort	Feder	Resorte	
	3	8000 22551	2	Anello OR	O-Ring	Bague OR	O-Ring	Anillo OR	
	4	8000 55902	1	Vite	Screw	Vis	Schraube	Tornillo	
	5	8000 69125	1	Camma regolazione	Cam	Came	Nocken	Excéntrico	
	6	8A00 55241	1	Vite per camma	Screw	Vis	Schraube	Tornillo	
	7	8000 70696	1	Perno	Control rod	Coulisseau	Steuerstange	Varilla	
	8	8000 56377	1	Rosetta	Washer	Rondelle	Scheibe	Arandela	
	9	64N1 20068	1	Copiglia	Split pin	Goupille	Splint	Clavija	
	10	8000 79075	1	Cuffia	Cap	Capuchons	Kappa	Gorro	
	11	8000 76338	1	Pompa comando freno compl.	Brake pump	Pompe frein	Bremspumpe	Bomba freno	
	12	8000 62728	2	Vite	Screw	Vis	Schraube	Tornillo	
	13	8000 45495	2	Bussola	Bushing	Douille	Buchse	Manguito	
	14	8000 88027	1	Protezione pompa freno	Guard	Protection	Schutz	Protección	
	15	8000 61078	1	Serbatoio olio completo	Oil tank assy	Reservoir huile compl.	Öltank Kpl.	Depósito aceite completo	
	16	8000 62727	1	Vite	Screw	Vis	Schraube	Tornillo	
	17	8000 44240	1	Dado	Nut	Ecrou	Mutter	Tuerca	
	18	8000 42349	2	Molletta	Spring	Ressort	Feder	Resorte	
	19	8B00 57760	1	Tubazione	Pipe	Tuyau	Rohr	Tubo	
	20	8000 21480	4	Rosetta di tenuta	Washer	Rondelle	Scheibe	Arandela	
	21	8000 94849	1	Interruttore stop posteriore	Stop switch	Interrupteur stop	Stopschalter	Interruptor stop	
	22	8000 78164	1	Tubo mandata olio	Pipe	Tuyau	Rohr	Tubo	
	23	8000 57155	1	Vite	Screw	Vis	Schraube	Tornillo	
	24	8000 79794	1	Pinza freno post.	Brake caliper	Eltrier frein	Bremssattel	Pinza	
	25	8000 85932	1	Gruppo revisione mollette	Spring set	Kit revision ressort	Federsatz	Grupo revis. resorte	
	26	8000 79066	1	Gruppo revisione cuffie	Caps revision set	Groupe revision capuchons	Kappa reparatursatz	Grupo revis. gorro	
	27	8000 79072	1	Coppia pastiglie	Pads pair	Paire plaquettes	Bremsbelagpaar	Pareja pastillas	
	29	8000 60404	1	Gruppo revisione spurgo	Bleeding set	Kit de revision curage	Reinigungsatz	Grupo revis. purga	
	30	8000 79073	1	Perno copiglia	Pin and split pin	Pivots et goupille	Bolzen und splint	Pernos y clavija	

Note Notes Notas	Pos. No. N. Index Pos.	N. Cod. Code No. Nr. Code Code Nr N. Cod.	Q.tà Q.ty Q.te M.ge C.ad	DENOMINAZIONE	NAME	DESIGNATION	BESHREIBUNG	DENOMINACION	Validità Validity Validité Gültig Validez
	1	80D0 87059	1	Parafango anteriore (codice colore F)	Front mudguard (color code F)	Garde-boue avant (code couleur F)	Vord. Kotfluegel (Code Farbe F)	Guarda-barros delantero (còdigo colòr F)	
	1	80F0 87059	1	Parafango anteriore (codice colore E)	Front mudguard (color code E)	Garde-boue avant (code couleur E)	Vord. Kotfluegel (Code Farbe E)	Guarda-barros delantero (còdigo colòr E)	
	2	8000 07001	2	Distanziale	Spacer	Entretoise	Distanzstück	Separador	
	3	8000 56359	4	Rosetta	Washer	Rondelle	Scheibe	Arandela	
	4	8000 69429	6	Bussola	Bushing	Douille	Buchse	Manguito	
	5	8000 62727	2	Vite (fiss. ant.)(M6x16mm)	Screw (M6x16mm)	Vis (M6x16mm)	Schraube (M6x16mm)	Tornillo (M6x16mm)	
	5	8000 62728	2	Vite (fiss. post.)(M6x20mm)	Screw (M6x20mm)	Vis (M6x20mm)	Schraube (M6x20mm)	Tornillo (M6x20mm)	
	6	8000 A1135	1	Sella (codice colore E)	Saddle (color code E)	Siège (code couleur E)	Sattel (Code Farbe E)	Sillin (còdigo colòr E)	
	6	8000 92158	1	Sella (codice colore F)	Saddle (color code F)	Siège (code couleur F)	Sattel (Code Farbe F)	Sillin (còdigo colòr F)	
	7	8000 A1136	1	Rivestimento sella (codice colore E)	Saddle covering (color code E)	Revetement selle (code couleur E)	Sattelvekleidung (Code Farbe E)	Revestimiento sillin (còdigo colòr E)	
	7	8000 92156	1	Rivestimento sella (codice colore F)	Saddle covering (color code F)	Revetement selle (code couleur F)	Sattelvekleidung (Code Farbe F)	Revestimiento sillin (còdigo colòr F)	
	8	8000 62730	1	Vite	Screw	Vis	Schraube	Tornillo	
	9	8H00 70208	1	Ass. pannello laterale Dx. (codice colore F)	R.H. panel assy (color code F)	Panneau compl., D. (code couleur F)	Streifen kpl., R. (Code Farbe F)	Panel compl., der. (còdigo colòr F)	
	9	8G00 70208	1	Ass. pannello laterale Dx. (codice colore E)	R.H. panel assy (color code E4)	Panneau compl., D. (code couleur E)	Streifen kpl., R. (Code Farbe E)	Panel compl., der. (còdigo colòr E)	
	10	8000 18048	2	Gommino	Rubber pad	Pièce caoutchouc	Gummstück	Junta de goma	
	11	8000 45490	3	Gommino	Rubber pad	Pièce caoutchouc	Gummstück	Junta de goma	
	12	80L0 70209	1	Pannello laterale Sx. (codice colore F)	L.H. panel (color code F)	Panneau, G. (code couleur F)	Streifen, L. (Code Farbe F)	Panel izq. (còdigo colòr F)	
	12	80H0 70209	1	Pannello laterale Sx. (codice colore E)	L.H. panel (color code E)	Panneau, G. (code couleur E)	Streifen, L. (Code Farbe E)	Panel izq. (còdigo colòr E)	
	13	8000 62727	1	Vite	Screw	Vis	Schraube	Tornillo	
	14	8000 62729	2	Vite	Screw	Vis	Schraube	Tornillo	
	15	8000 45495	4	Bussola	Bushing	Douille	Buchse	Manguito	
	16	8000 87996	1	Piastra portapacchi	Plate	Plaque	Platte	Placa	
	17	8B00 67207	4	Distanziale	Spacer	Entretoise	Distanzstück	Separadòr	

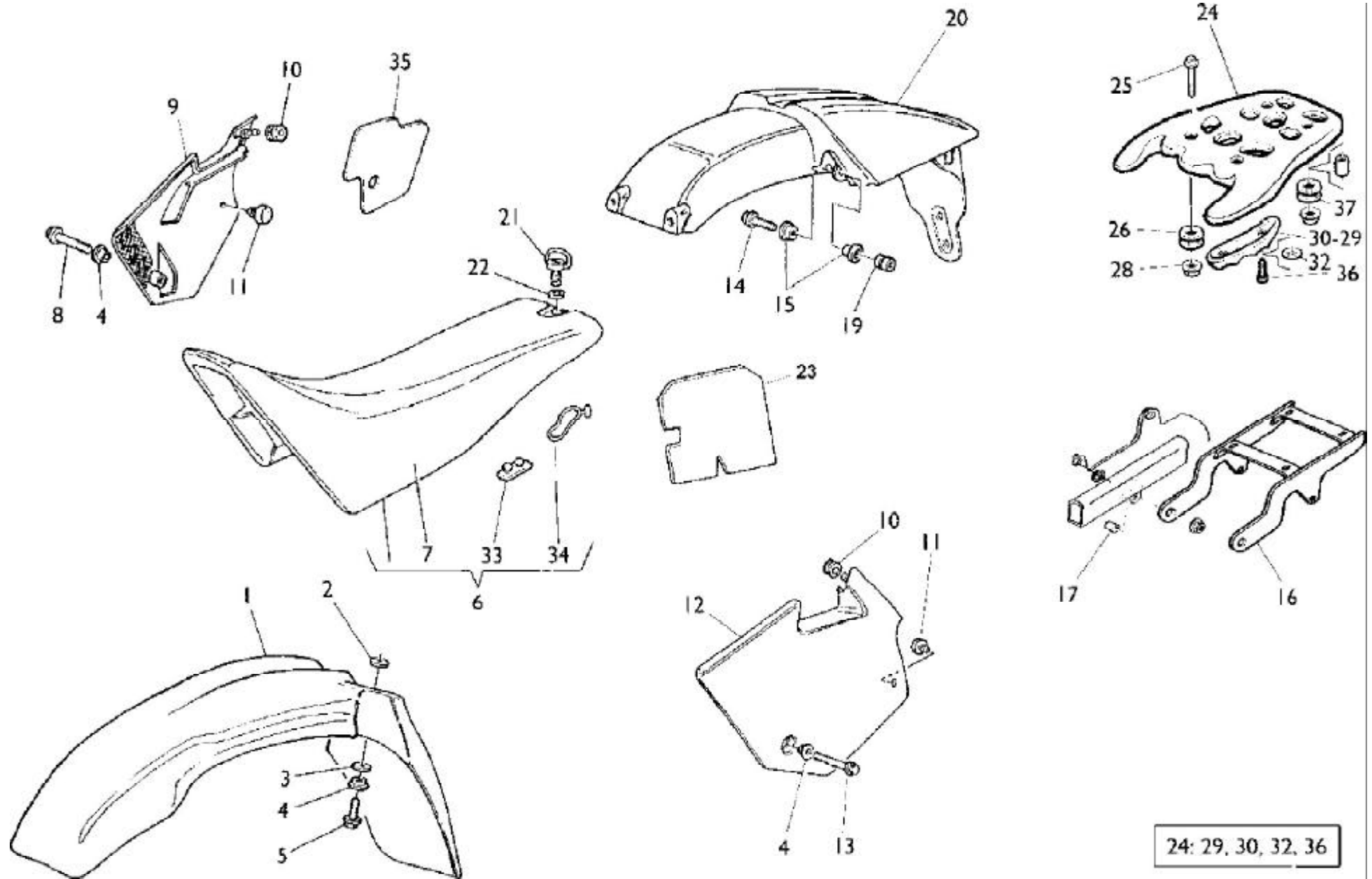

Note Notes Notas	Pos. No. Index Pos.	N. Cod. Code No. Nr. Code Code Nr N. Cod.	Q.tà Q.ty Q.te M.ge C.ad	DENOMINAZIONE	NAME	DESIGNATION	BESHREIBUNG	DENOMINACION	Validità Validity Validité Gültig Validez
	19	8000 56409	2	Dado	Nut	Ecrou	Mutter	Tuerca	
	20	8BA0 89851	1	Parafango posteriore (codice colore E)	Rear mudguard (color code E)	Garde-boue arriere (code couleur E)	Hint. Kotfluegel (Code Farbe E)	Guarda-barros trasero (còdigo colòr E)	
	20	8BC0 89851	1	Parafango posteriore (codice colore F)	Rear mudguard (color code F)	Garde-boue arriere (code couleur F)	Hint. Kotfluegel (Code Farbe F)	Guarda-barros trasero (còdigo colòr F)	
	21	8000 69148	1	Perno	Pin	Pivot	Bolzen	Perno	
	22	8000 69149	1	Rosetta elastica	Spring washer	Rondelle elésique	Federscheibe	Arandela elastica	
	23	8000 72348	1	Protezione	Guard	Protectiÿn	Schutz	Protecciòn	
	24	8000 88071	1	Ass. portapacchi	Parcel rack	Porte bagages	Gepackhalter	Porta equipaje	
	25	8000 63948	4	Vite	Screw	Vis	Schraube	Tornillo	
	26	8000 88070	2	Gommino anteriore	Front rubber pad	Pièce caoutchouc avant	Vordergummistück	Junta de goma delantero	
	28	8000 44240	4	Dado	Nut	Ecrou	Mutter	Tuerca	
	29	8000 87994	1	Maniglia Dx	R.H. handle	Poignée droite	Handgriff Rechts	Manilla derecha	
	30	8000 87995	1	Maniglia Sx	L.H. handle	Poignée gauche	Handgriff Links	Manilla izquierda	
	31	8000 44240	4	Dado	Nut	Ecrou	Mutter	Tuerca	
	32	62N1 15547	4	Rosetta	Washer	Rondelle	Scheibe	Arandela	
	33	8000 33491	3	Gommino	Rubber pad	Pièce caoutchouc	Gummistück	Junta de goma	
	34	8000 31981	1	Elastico	Elastic	Elastique	Elastisch	Elàstico	
	35	8000 90228	1	Protezione	Guard	Protectiòn	Schutz	Protecciòn	
	36	8000 27403	4	Vite	Screw	Vis	Schraube	Tornillo	
	37	8000 92224	2	Gommino posteriore	Rear rubber pad	Pièce caoutchouc arriere	Hintergummistück	Junta de goma trasero	



TE E 610 dual purpose -
SMS 610 / 2004

TAVOLA
DRAWING
TABLE
BILD
TABLA

22

SERBATOIO CARBURANTE - GAS TANK
RESERVOIR CARBURANT - KRAFTSTOFFBEHALTER
DEPOSITO GASOLINA

Note Notes Notas	Pos. No. N. Index Pos.	N. Cod. Code No. Nr. Code Code Nr N. Cod.	Q.tà Q.ty Q.te M.ge C.ad	DENOMINAZIONE	NAME	DESIGNATION	BESHREIBUNG	DENOMINACION	Validità Validity Validité Gültig Validez
	1	8AB0 66630	1	Serbatoio carburante (l 9)	Fuel tank (l 9)	Réservoir à carburant (l 9)	Tank (l 9)	Depósito gasolina (l 9)	
	2	8000 94098	1	Tappo	Plug	Bouchon	Verschluss	Tapón	
	3	8000 56381	1	Guarnizione	Gasket	Garniture	Dichtung	Junta	
	4	60N1 04134	1	Vite	Screw	Vis	Schraube	Tornillo	
	5	8000 66238	1	Distanziale	Spacer	Entretoise	Distanzstück	Separador	
	6	60N1 07350	2	Vite	Screw	Vis	Schraube	Tornillo	
	7	8000 40813	2	Tampone	Pad	Tampon	Stopfen	Tampón	
	8	8000 67440	1	Rubinetto Sx.	L.H. cock	Robinet G.	L. Kraftstoffahn	Llave de paso izq.	
	9	8000 01199	2	Anello OR	O-Ring	Bague OR	O-Ring	Anillo OR	
	10	8000 37745	4	Vite	Screw	Vis	Schraube	Tornillo	
	12	8B00 38752	1	Tubetto sfiato	Breather hose	Tuyau	Roho	Tube	
	13	8000 62725	1	Vite	Screw	Vis	Schraube	Tornillo	
	14	8000 30319	1	Rosetta piana	Washer	Rondelle	Schaibe	Arandela	
	15	8000 61362	1	Tampone	Pad	Tampon	Stopfen	Tampón	
	16	8000 88240	1	Guarnizione	Gasket	Guarnitue	Dichtung	Junta	
	17	8000 98243	1	Rubinetto Dx.	R.H. cock	Robinet D.	R. Kraftstoffahn	Llave de paso der.	
	18	8G00 84311	1	Condotto benzina (190 mm)	Hose (190 mm)	Tuyau (190 mm)	Rohr (190 mm)	Tube (190 mm)	
SS	18	8L00 84311	1	Condotto benzina (245 mm)	Hose (245 mm)	Tuyau (245 mm)	Rohr (245 mm)	Tube (245 mm)	
TT	18	8L00 84311	1	Condotto benzina (95 mm)	Hose (95 mm)	Tuyau (95 mm)	Rohr (95 mm)	Tube (95 mm)	
	19	8000 42349	4	Fascetta serratubo	Clamp	Colliér	Schelle	Banda	

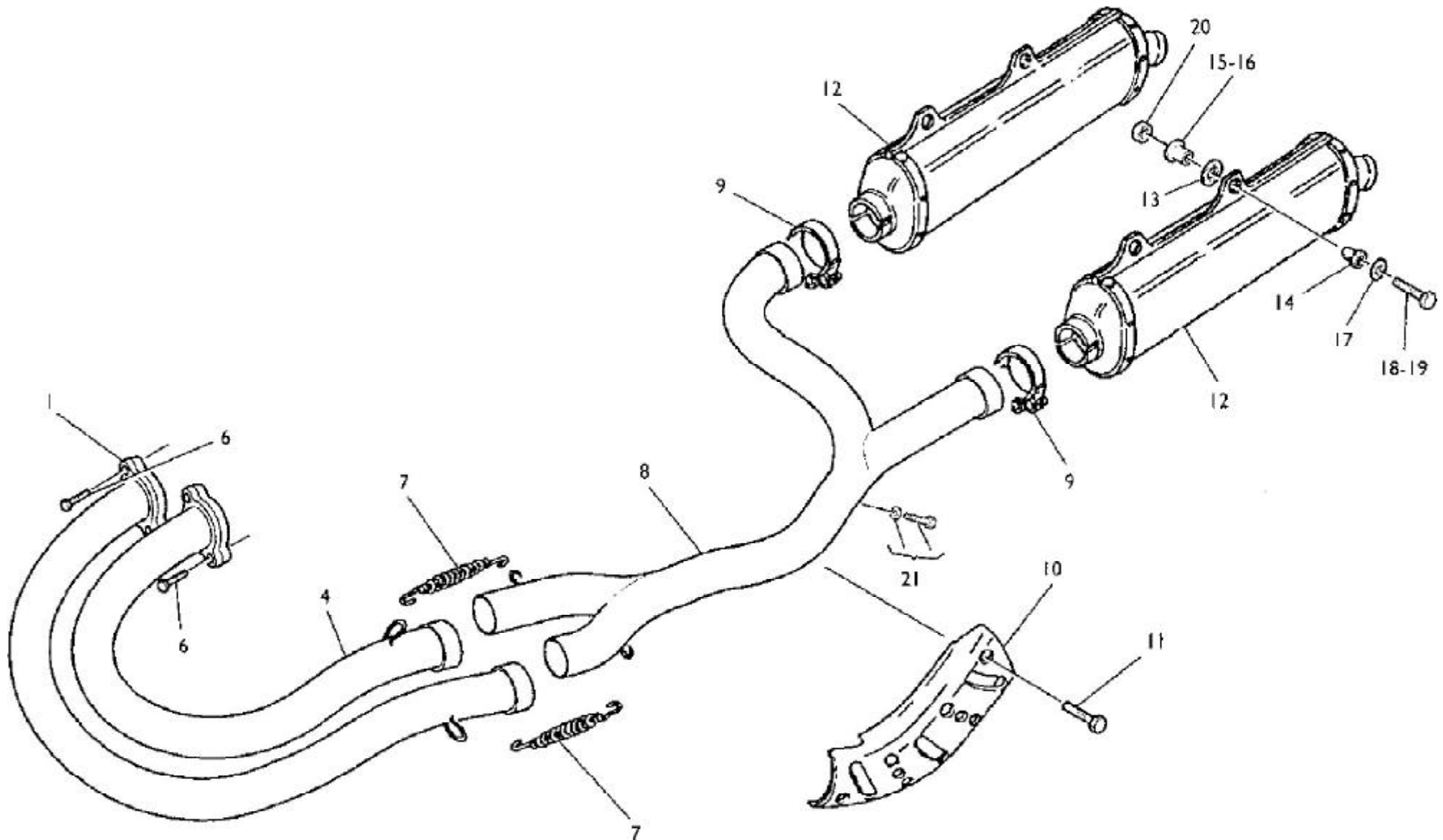

Note Notes Notas	Pos. No. N. Index Pos.	N. Cod. Code No. Nr. Code Code Nr N. Cod.	Q.tà Q.ty Q.te M.ge C.ad	DENOMINAZIONE	NAME	DESIGNATION	BESCHREIBUNG	DENOMINACION	Validità Validity Validité Gültig Validez
	1	8000 87091	1	Tubo di scarico Dx	Exhaust pipe R.H.	Tuyau d'echappement D.	R. Auspuffrohr	Tubo de escape der.	
	4	8000 87092	1	Tubo di scarico Sx	Exhaust pipe L.H.	Tuyau d'echappement G.	L. Auspuffrohr	Tubo de escape iz.	
	6	60N4 02509	4	Viti fiss. tubo scarico alla testa	Screw	Vis	Schraube	Tornillo	
	7	8000 67496	2	Molla	Springs	Ressort	Feder	Resorte	
	8	8000 87105	1	Raccordo silenziatore-scarico	Union	Raccord	Anschluss	Empalme	
	9	8000 72411	2	Fascetta	Clamp	Collier	Schelle	Banda	
	10	8000 89644	1	Griglia protezione calore	Grille	Grille	Gitter	Rejilla de proteccìon	
	11	8000 43015	3	Vite	Screw	Vis	Schraube	Tornillo	
	12	8000 A3987	2	Silenziatore di scarico	Exhaust silencer	Silencieux d'echappement	Schalldämpfer	Silenciador de escape	
	13	1514 10702	4	Gommino	Rubber pad	Pièce caoutchouc	Gummistück	Junta de goma	
	14	1513 41401	4	Gommino	Rubber pad	Pièce caoutchouc	Gummistück	Junta de goma	
	15	8000 70379	2	Distanziale SX	L.H. Spacer	Entretoise G.	L. Distanzstück	Separador iz.	
	16	8B00 70379	2	Distanziale DX	R.H. Spacer	Entretoise D.	R. Distanzstück	Separador der.	
	17	1513 74301	4	Rosetta	Washer	Rondelle	Scheibe	Arandela	
	18	8B00 67545	2	Vite lato Sx. (M6x55mm)	L.H. Screw (M6x55mm)	Vis G. (M6x55mm)	L. Schraube (M6x55mm)	Tornillo iz. (M6x55mm)	
	19	8D00 67545	2	Vite lato Dx. (M6x60mm)	R.H. Screw (M6x60mm)	Vis D. (M6x60mm)	R. Schraube (M6x60mm)	Tornillo der. (M6x60mm)	
	20	8000 44240	4	Dado autobloccante	Nut	Ecrou	Mutter	Tuerca	
	21	8000 67703	1	Tappo per raccordo	Plug	Bouchon	Verschluss	Tapón	

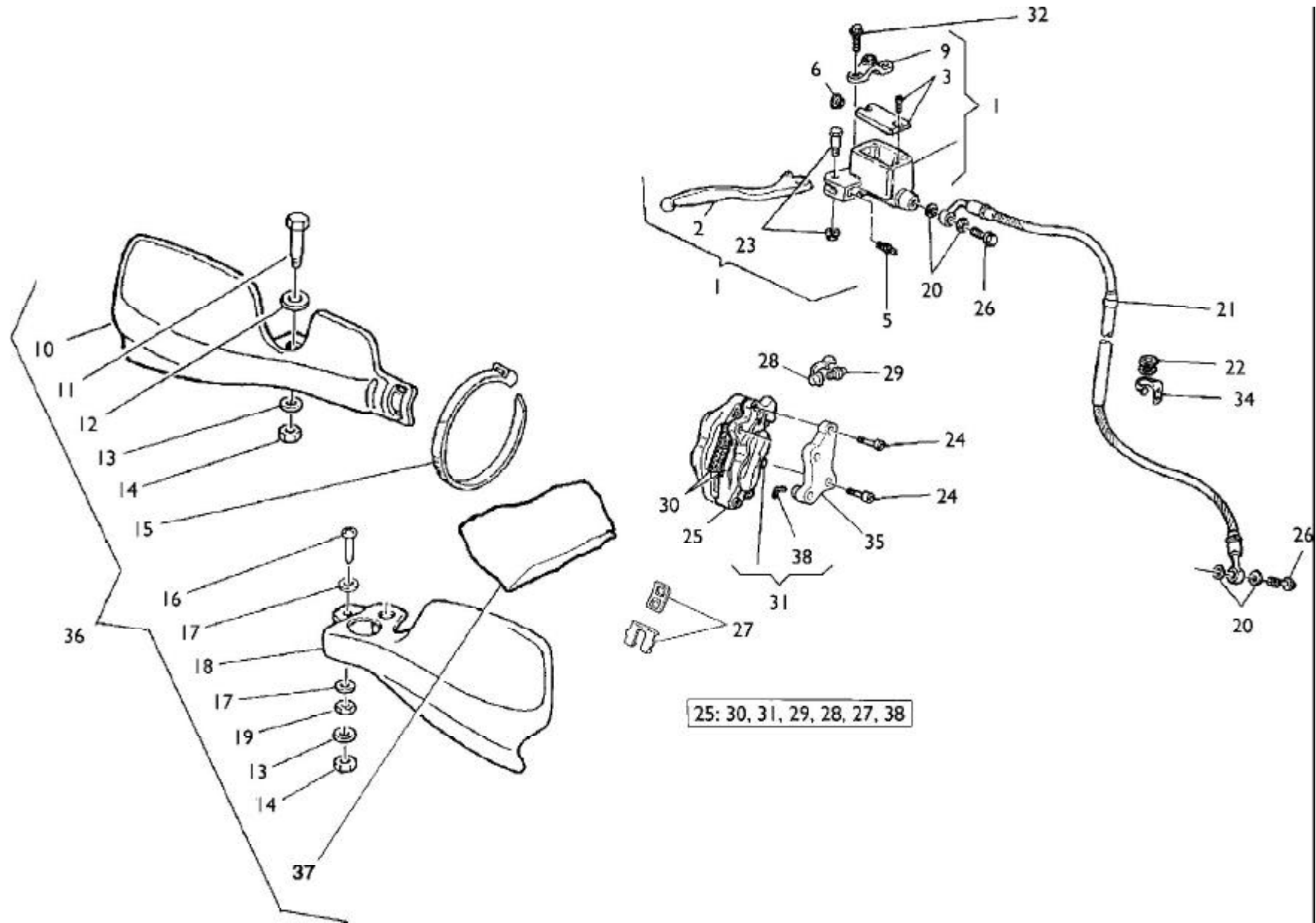

Note Notes Notes Marke Notas	Pos. No. N. Index Pos.	N. Cod. Code No. Nr. Code Code Nr N. Cod.	Q.tà Q.ty Q.te M.ge C.ad	DENOMINAZIONE	NAME	DESIGNATION	BESHREIBUNG	DENOMINACION	Validità Validity Validité Gültig Validez
	1	8A00 76024	1	Pompa com. freno anteriore	Brake pump	Pompe frein	Bremspumpe	Bomba freno	
	2	8A00 79067	1	Leva	Lever set	Kit revision levier	Hebelbolzensatz	Grupo revis. perno	
	3	8000 79069	1	Kit tappo	Plug kit	Bouchon kit	Verschluss Gruppe	Kit tapón	
	5	8000 95248	1	Interruttore stop	Stop switch	Interrupteur stop	Stopschalter	Interruptor stop	
	6	8000 49654	1	Oblò	Inspection plug	Capuchon de inspection	Stopfen	Portilla	
	9	8000 79068	1	Cavallotto	U-bolt	Cavalier	Bügelbolzen	Caballete	
D	10	80A0 86523	1	Paramano Dx	R.H. guard	Protection D	Schutz R.	Protección der.	
D	11	8000 86515	1	Vite	Screw	Vis	Schraube	Tornillo	
D	12	62N1 15506	1	Rosetta	Washer	Rondelle	Scheibe	Arandela	
D	13	8000 56359	2	Rosetta	Washer	Rondelle	Scheibe	Arandela	
D	14	8000 61313	2	Dado	Nut	Ecrou	Mutter	Tuerca	
D	15	8000 56444	1	Fascetta (188mm)	Clamp (188mm)	Collier (188mm)	Schelle (188mm)	Abrazadera(188mm)	
D	16	8CA0 50798	1	Vite	Screw	Vis	Schraube	Tornillo	
D	17	8000 47662	2	Rosetta	Washer	Rondelle	Scheibe	Arandela	
D	18	8000 94609	1	Paramano Sx	L.H. guard	Protection G.	Schutz L.	Protección izq.	
D	19	61N1 15191	1	Dado	Nut	Ecrou	Mutter	Tuerca	
	20	8000 21480	4	Rosetta di tenuta	Washer	Rondelle	Scheibe	Arandela	
	21	8A00 87053	1	Tubo mandata olio	Pipe	Tuyau	Rohr	Tubo	
	22	8000 71806	1	Guida cavo	Cable guide	Guide câble	Kabelführung	Guía-cable	
	23	8000 79070	1	Perno	Pin	Pivot	Bolzen	Perno	
	24	8C00 62797	4	Vite	Screw	Vis	Schraube	Tornillo	
	25	8000 88771	1	Pinza freno	Brake caliper	Etrier frein	Bremssattel	Pinza	
	26	8000 57155	2	Bocchettone	Pipe union	Goulotte	Stutzen	Boca	
	27	8000 88776	1	Mollette lamierino	Spring kit	Kit ressort	Federgruppe	Grupo resorte	
	28	8000 88775	1	Parapolvere	Dust cover	Para poussière	Staubdeckel	Tapa retención polvo	
	29	8000 88774	1	Vite per spurgo	Bleeding set	Kit de revision curage	Reinigungsatz	Grupo revis. purga	
	30	8000 88772	1	Coppia pastiglie	Pads pair	Paire plaquettes	Bremsbelagpaar	Pareja pastillas	
	31	8000 88773	1	Perno	Pin	Pivot	Bolzen	Perno	
	32	8000 62729	2	Vite	Screw	Vis	Schraube	Tornillo	
	33	8000 79066	1	Gruppo revisione cuffie	Caps revision set	Groupe revision capuchons	Kappa reparaturrensatz	Grupo revis. gorro	
	34	8000 90104	1	Piastrina	Plate	Plaquette	Plättchen	Placa	
	35	8000 88782	1	Piastra	Plate	Plaquette	Plättchen	Placa	
D	36	8000 94614	1	Kit paramani	Guards Kit	Kit protection	Schutzgruppe kpl	Grupo protection	

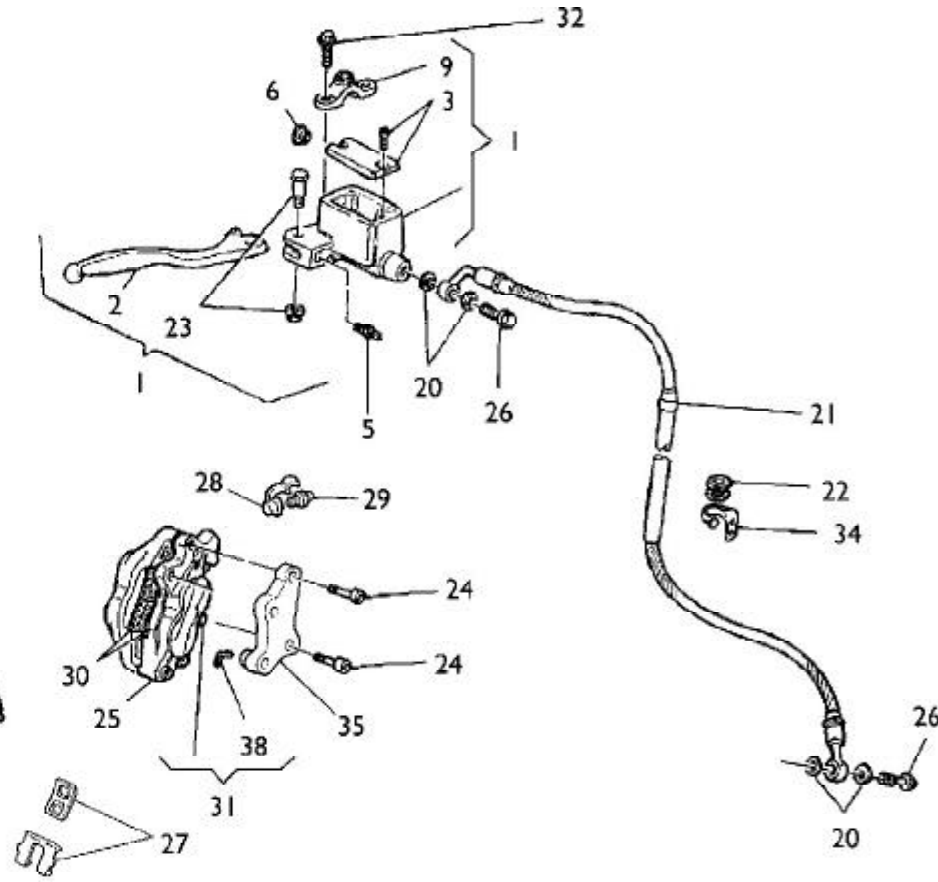
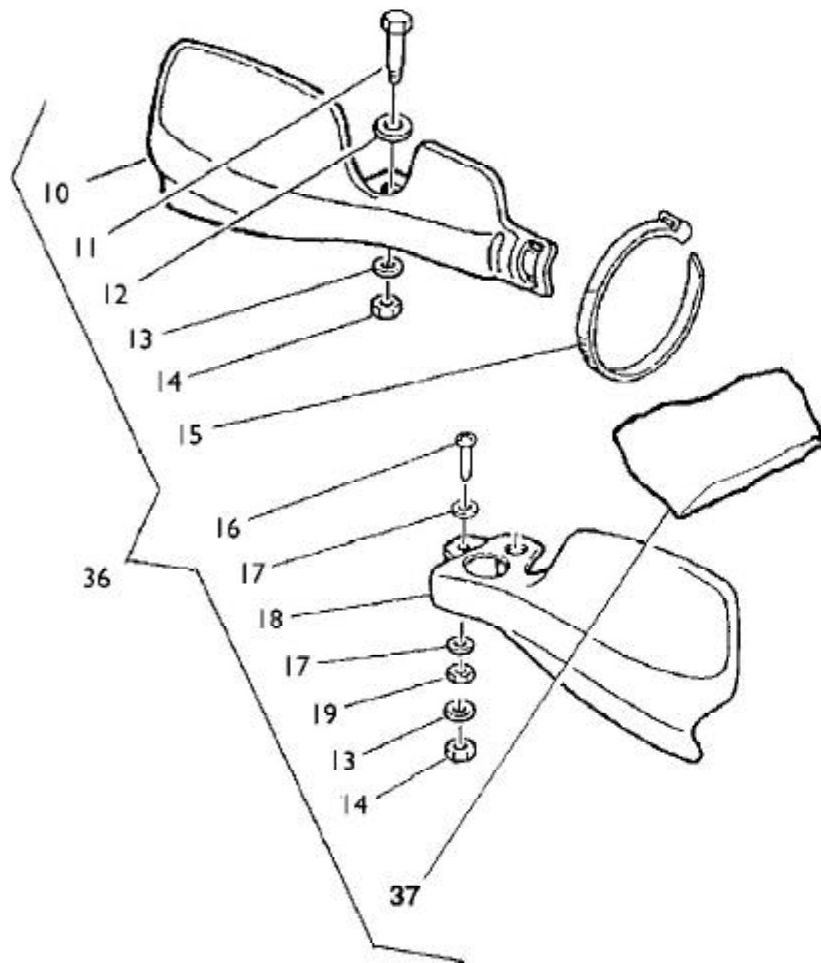

25: 30, 31, 29, 28, 27, 38

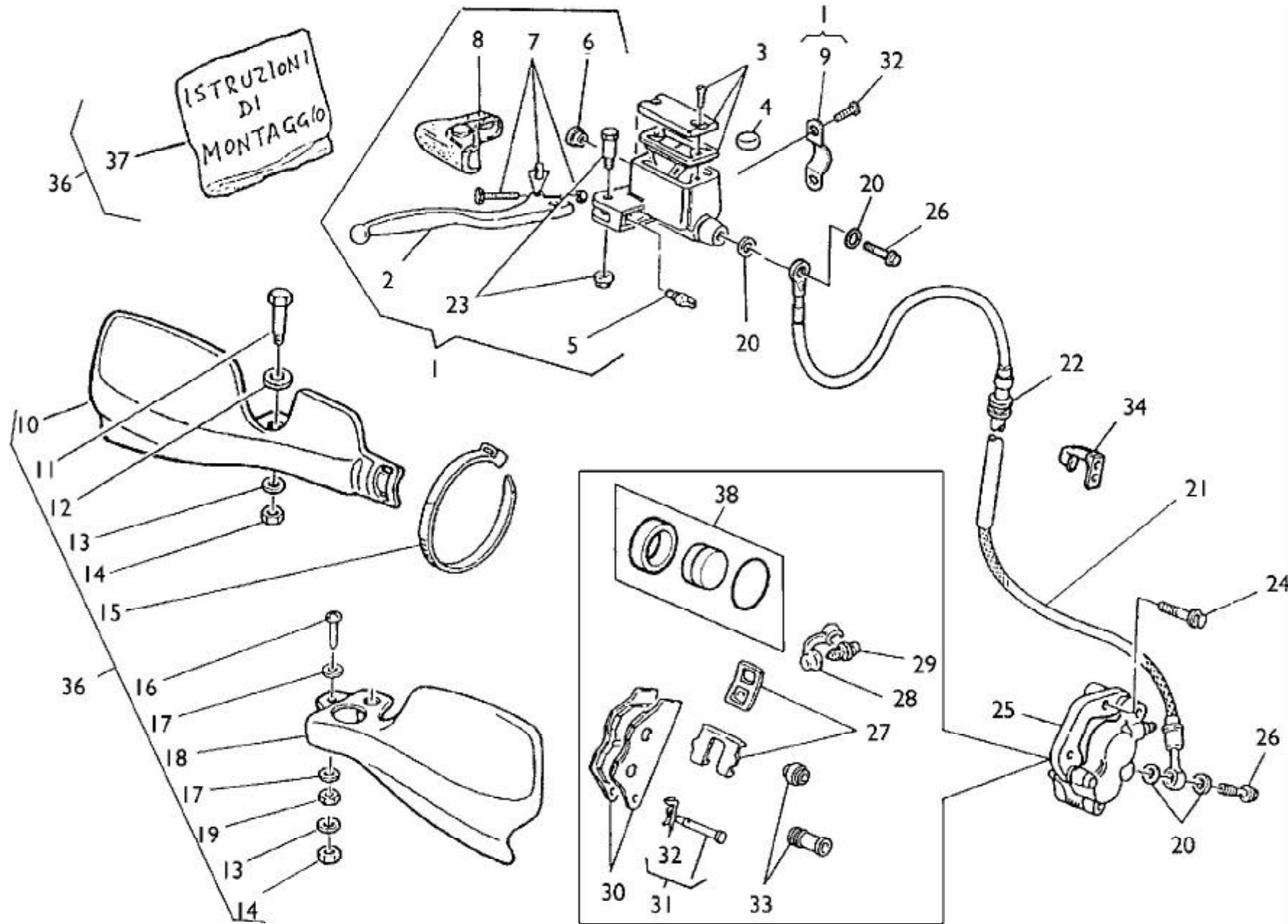

Note Notes Notas	Pos. No. N. Index Pos.	N. Cod. Code No. Nr. Code Code Nr N. Cod.	Q.tà Q.ty Q.te M.ge C.ad	DENOMINAZIONE	NAME	DESIGNATION	BESHREIBUNG	DENOMINACION	Validità Validity Validité Gültig Validez
	1	8B00 77740	1	Pompa com. freno anteriore	Brake pump	Pompe frein	Bremspumpe	Bomba freno	
	2	8000 79096	1	Leva	Lever set	Kit revision levier	Hebelbolzensatz	Grupo revis. perno	
	3	8000 79069	1	Kit tappo	Plug kit	Bouchon kit	Verschluss Gruppe	Kit tapón	
	4	8000 79099	1	Antiemulsione	Antiemulsion	Antiemulsion	Emulsionswidriger	Antiemulsion	
	5	8000 95248	1	Interruttore stop	Stop switch	Interrupteur stop	Stopschalter	Interruptor stop	
	6	8000 49654	1	Oblò	Inspection plug	Capuchon de inspection	Stopfen	Portilla	
	7	8000 79100	1	Regolazione leva	Lever set	Kit levier	Hebel gruppe	Grupo palanca	
	8	8000 79098	1	Cappuccio	Cap kit	Kit capuchon	Kappe Gruppe	Kit capuchón	
	9	80A0 79068	1	Cavallotto	U-bolt	Cavalier	Bügelbolzen	Caballete	
D	10	80A0 86523	1	Paramano Dx (codice colore E-F)	R.H. guard (color code E-F)	Protection D (code couleur E-F)	Schutz R. (Code Farbe E-F)	Protección der. (còdigo colòr E-F)	
D	11	8000 86515	1	Vite	Screw	Vis	Schraube	Tornillo	
D	12	62N1 15506	1	Rosetta	Washer	Rondelle	Scheibe	Arandela	
D	13	8000 56359	2	Rosetta	Washer	Rondelle	Scheibe	Arandela	
D	14	8000 61313	2	Dado	Nut	Ecrou	Mutter	Tuerca	
D	15	8000 56444	1	Fascetta (188mm)	Clamp (188mm)	Collier (188mm)	Schelle (188mm)	Abrazadera(188mm)	
D	16	8CA0 50798	1	Vite	Screw	Vis	Schraube	Tornillo	
D	17	8000 47662	2	Rosetta	Washer	Rondelle	Scheibe	Arandela	
D	18	8000 94609	1	Paramano Sx (codice colore E-F)	L.H. guard (color code E-F)	Protection G. (code couleur E-F)	Schutz L. (Code Farbe E-F)	Protección izq. (còdigo colòr E-F)	
D	19	61N1 15191	1	Dado	Nut	Ecrou	Mutter	Tuerca	
	20	8000 21480	4	Rosetta di tenuta	Washer	Rondelle	Scheibe	Arandela	
	21	8000 87053	1	Tubo mandata olio	Pipe	Tuyau	Rohr	Tubo	
	22	8000 71806	1	Guida cavo	Cable guide	Guide câble	Kabelführung	Guía-cable	
	23	8000 79070	1	Perno	Pin	Pivot	Bolzen	Perno	
	24	8000 62733	1	Vite (M8x35mm)	Screw (M8x35mm)	Vis (M8x35mm)	Schraube (M8x35mm)	Tornillo (M8x35mm)	
	24	8A00 69056	1	Vite (M8x45mm)	Screw (M8x45mm)	Vis (M8x45mm)	Schraube (M8x45mm)	Tornillo (M8x45mm)	
	25	8000 85998	1	Pinza freno	Brake caliper	Etrier frein	Bremssattel	Pinza	
	26	8000 57155	2	Bocchettone	Pipe union	Goulotte	Stutzen	Boca	
	27	8000 79065	1	Mollette lamierino	Spring kit	Kit ressort	Federgruppe	Grupo resorte	
	28	8000 53259	1	Parapolvere	Dust cover	Para poussière	Staubdeckel	Tapa retención polvo	
	29	8000 60404	1	Vite per spurgo	Bleeding set	Kit de revision curage	Reinigungsatz	Grupo revis. purga	
	30	8A00 74181	1	Coppia pastiglie	Pads pair	Paire plaquettes	Bremsbelagpaar	Pareja pastillas	

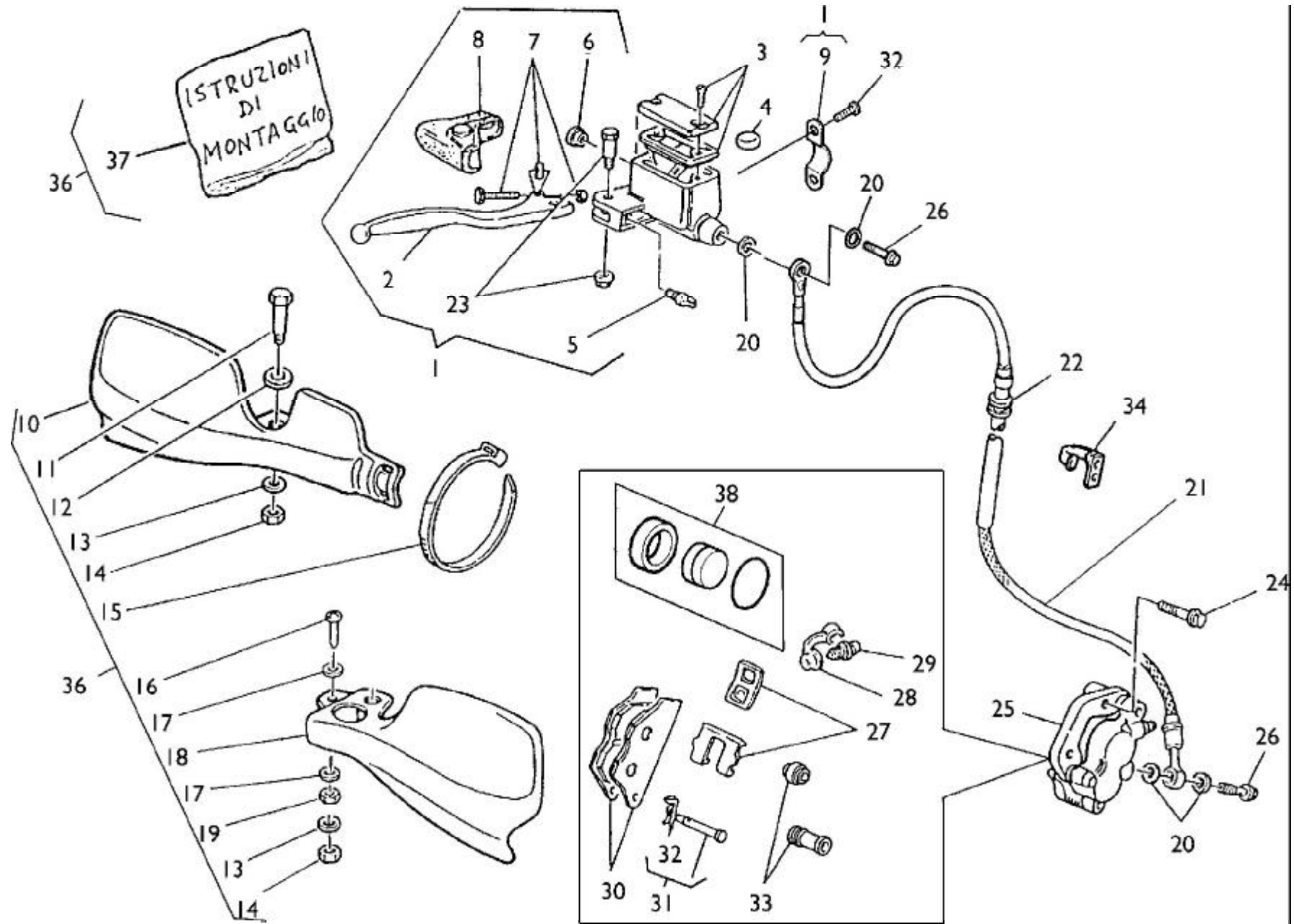

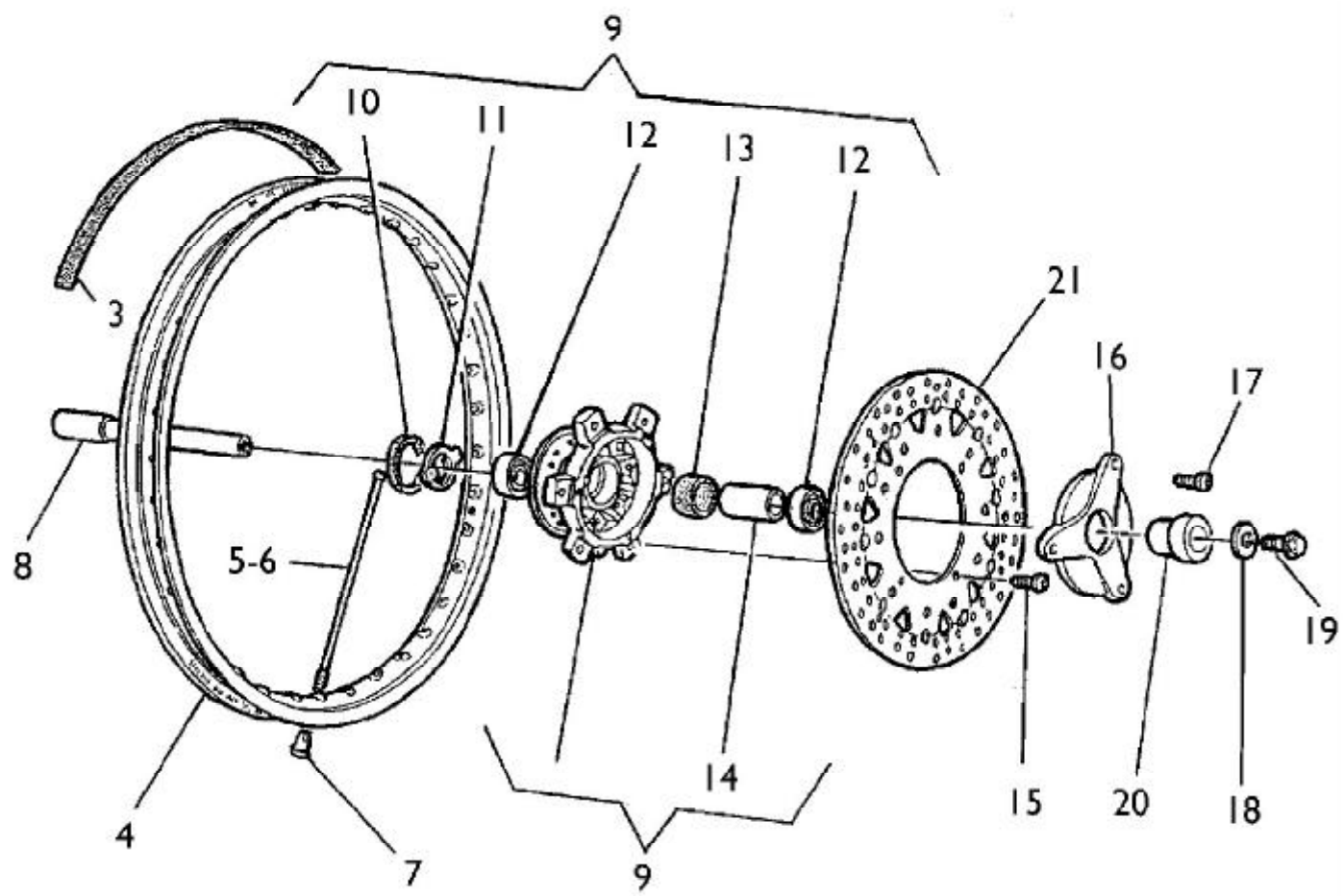

Note Notes Notas	Pos. No. N. Index Pos.	N. Cod. Code No. Nr. Code Code Nr N. Cod.	Q.tà Q.ty Q.te M.ge C.ad	DENOMINAZIONE	NAME	DESIGNATION	BESHREIBUNG	DENOMINACION	Validità Validity Validité Gültig Validez
	3	8B00 82879	1	Fascia copriraggi	Rim strip	Bande	Band	Banda	
	4	8000 94709	1	Cerchio (3,5x17")	Rim (3,5x17")	Jante (3,5x17")	Felge (3,5x17")	Llanta (3,5x17")	
	5	8A00 88672	18	Raggio Dx. (L=171,5mm)	Spoke R. (L=171,5mm)	Bras D. (L=171,5mm)	Speiche R. (L=171,5mm)	Radio der. (L=171,5mm)	
	6	8A00 88671	18	Raggio Sx. (L=169,5mm)	Spoke L. (L=169,5mm)	Bras G. (L=169,5mm)	Speiche L. (L=169,5mm)	Radio izq. (L=169,5mm)	
	7	69N4 29004	36	Nipplo	Nipple	Nipple	Nippel	Nipple	
	8	8A00 75042	1	Perno ruota	Pin	Pivot	Bolzen	Perno rueda	
	9	8000 77744	1	Mozzo completo	Hub assy	Moyeau compl.	Radnabe, Kpl.	Cubo compl.	
	10	8000 51957	1	Anello di tenuta (ø40xø50x4mm)	Seal ring (ø40xø50x4mm)	Bague d'étanchéité (ø40xø50x4mm)	Dichtungsring (ø40xø50x4mm)	Anillo de retención (ø40xø50x4mm)	
	11	8000 77884	1	Anello trascinatore	Ring	Bague	Ring	Anillo	
	12	8000 39651	2	Cuscinetto a sfere (ø20xø42x12mm)	Ball bearing (ø20xø42x12mm)	Roulement à billes (ø20xø42x12mm)	Kugellager (ø20xø42x12mm)	Cojinete de bolas (ø20xø42x12mm)	
	13	1516 21501	1	Portadistanziale	Spacer holder	Porte-entretoise	Abstandstückhalter	Porta-distancial	
	14	8A00 74718	1	Distanziale	Spacer	Entretoise	Distanzstück	Separador	
	15	8000 62726	6	Vite	Screw	Vis	Schraube	Tornillo	
	16	8B00 65572	1	Coperchio parapolvere	Dust cover	Pare poussière	Staubdeckel	Tapa retención polvo	
	17	8A00 62129	3	Vite	Screw	Vis	Schraube	Tornillo	
	18	8000 48772	1	Rosetta piana	Washer	Rondelle	Scheibe	Arandela	
	19	8000 48773	1	Vite	Screw	Vis	Schraube	Tornillo	
	20	8000 75043	1	Distanziale	Spacer	Entretoise	Distanzstück	Separador	
	21	8000 88770	1	Disco freno (ø320mm)	Brake disc (ø320mm)	Disque frein (ø320mm)	Bremsscheibe (ø320mm)	Disco freno (ø320mm)	

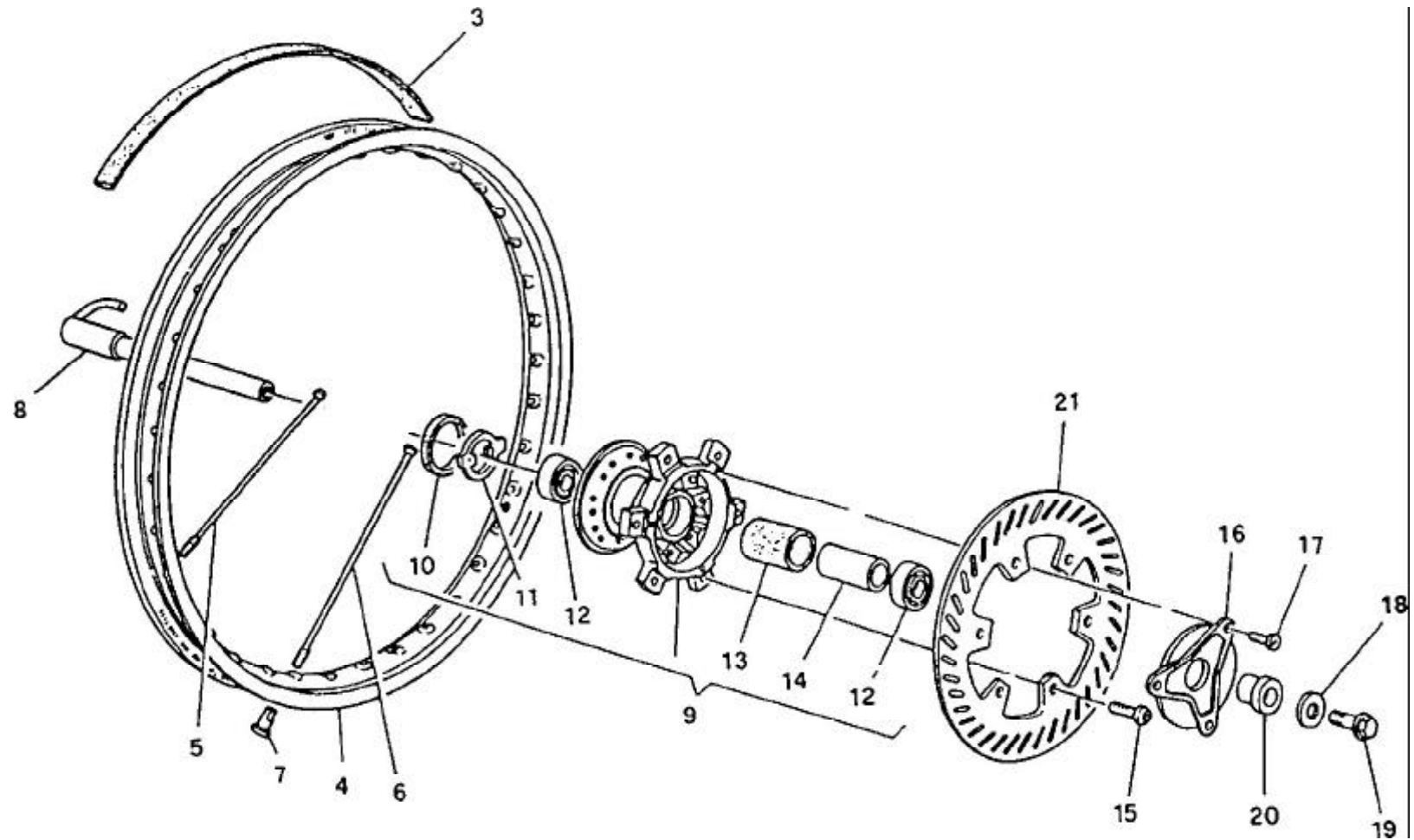

Note Notes Marka Notas	Pos. No. N. Index Pos.	N. Cod. Code No. Nr. Code Code Nr N. Cod.	Q.tà Q.ty Q.te M.ge C.ad	DENOMINAZIONE	NAME	DESIGNATION	BESHREIBUNG	DENOMINACION	Validità Validity Validité Gültig Validez
	3	8000 13346	1	Fascia copriraggi	Rim strip	Bande	Band	Banda	
	4	8000 94624	1	Cerchio (1,6x21")	Rim (1,6x21")	Jante (1,6x21")	Felge (1,6x21")	Llanta (1,6x21")	
	5	8000 65285	18	Raggio Dx.	Spoke R.	Bras D.	Speiche R.	Radio der.	
	6	8000 61014	18	Raggio Sx.	Spoke L.	Bras G.	Speiche L.	Radio izq.	
	7	69N4 29004	36	Nipplo	Nipple	Nipple	Nippel	Nipple	
	8	8A00 75042	1	Perno ruota	Pin	Pivot	Bolzen	Perno rueda	
	9	8000 77744	1	Mozzo completo	Hub assy	Moyeau compl.	Radnabe, Kpl.	Cubo compl.	
	10	8000 51957	1	Anello di tenuta (ø40xø50x4mm)	Seal ring (ø40xø50x4mm)	Bague d'étanchéité (ø40xø50x4mm)	Dichtungsring (ø40xø50x4mm)	Anillo de retención (ø40xø50x4mm)	
	11	8000 77884	1	Anello trascinatore	Ring	Bague	Ring	Anillo	
	12	8000 39651	2	Cuscinetto a sfere	Ball bearing	Roulement à billes	Kugellager	Cojinete de bolas	
	13	1516 21501	1	Portadistanziale	Spacer holder	Porte-entretoise	Abstandstückhalter	Porta-distancial	
	14	8A00 74718	1	Distanziale	Spacer	Entretoise	Distanzstück	Separador	
	15	8A00 55241	6	Vite	Screw	Vis	Schraube	Tornillo	
	16	8B00 65572	1	Coperchio parapolvere	Dust cover	Pare poussière	Staubdeckel	Tapa retención polvo	
	17	8A00 62129	3	Vite	Screw	Vis	Schraube	Tornillo	
	18	8000 48772	1	Rosetta piana	Washer	Rondelle	Scheibe	Arandela	
	19	8000 48773	1	Vite	Screw	Vis	Schraube	Tornillo	
	20	8000 75043	1	Distanziale	Spacer	Entretoise	Distanzstück	Separador	
	21	8000 73226	1	Disco freno (ø260mm)	Brake disc (ø260mm)	Disque frein (ø260mm)	Bremsscheibe (ø260mm)	Disco freno (ø260mm)	

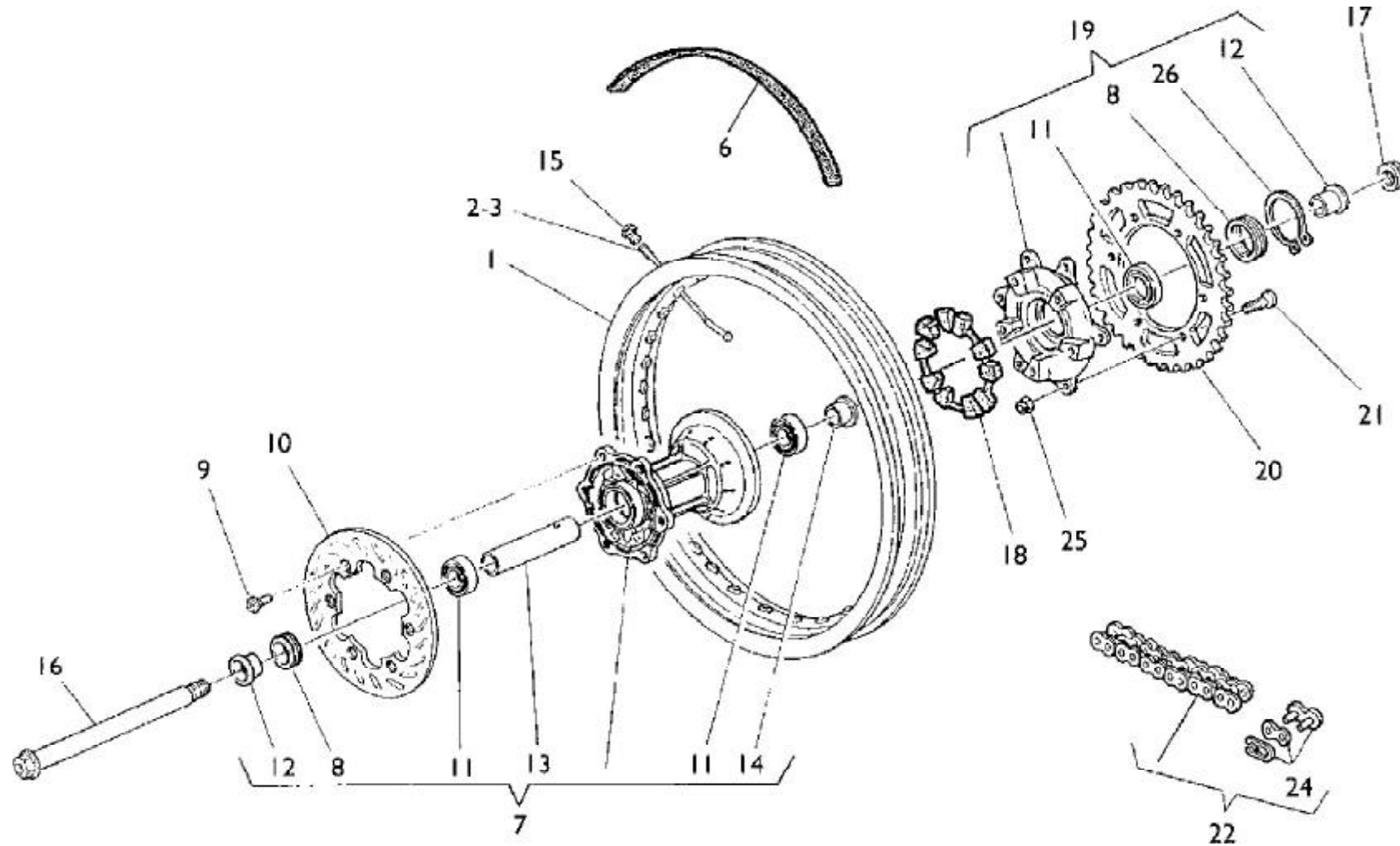

Note Notes Notas	Pos. No. Index Pos.	N. Cod. Code No. Nr. Code Code Nr N. Cod.	Q.tà Q.te M.ge C.ad	DENOMINAZIONE	NAME	DESIGNATION	BESHREIBUNG	DENOMINACION	Validità Validity Validité Gültig Validez
SS	1	8000 94710	1	Cerchio (4,25 x 17")	Rim (4,25 x 17")	Jante (4,25 x 17")	Felge (4,25 x 17")	Llanta (4,25 x 17")	
TT	1	8000 94705	1	Cerchio (2,5 x 18")	Rim (2,5 x 18")	Jante (2,5 x 18")	Felge (2,5 x 18")	Llanta (2,5 x 18")	
SS	2	8A00 88780	18	Raggio lato freno (L=187 mm)	Spoke (L=187 mm)	Bras (L=187 mm)	Speiche (L=187 mm)	Radio (L=187 mm)	
TT	2	8000 86936	18	Raggio lato freno	Spoke	Bras	Speiche	Radio	
SS	3	8A00 88781	18	Raggio lato corona (L 199 mm)	Spoke (L=199 mm)	Bras (L=199 mm)	Speiche (L=199 mm)	Radio (L=199 mm)	
TT	3	8000 86937	18	Raggio lato corona	Spoke	Bras	Speiche	Radio	
SS	6	8B00 82879	1	Fascia copriraggi	Rim strip	Bande	Band	Banda	
TT	6	8000 01688	1	Fascia copriraggi	Rim strip	Bande	Band	Banda	
	7	8000 87115	1	Mozzo completo	Hub assy	Moyeau compl.	Radnabe, Kpl.	Cubo compl.	
	8	8000 71570	2	Anello di tenuta ($\varnothing 30 \times \varnothing 47 \times 7 \text{mm}$)	Seal ring ($\varnothing 30 \times \varnothing 47 \times 7 \text{mm}$)	Bague d'étanchéité ($\varnothing 30 \times \varnothing 47 \times 7 \text{mm}$)	Dichtungsring ($\varnothing 30 \times \varnothing 47 \times 7 \text{mm}$)	Anillo de retención ($\varnothing 30 \times \varnothing 47 \times 7 \text{mm}$)	
	9	8000 55878	6	Vite	Screw	Vis	Schraube	Tornillo	
	10	8000 73225	1	Disco freno ($\varnothing 220 \text{mm}$)	Brake disc ($\varnothing 220 \text{mm}$)	Disque frein ($\varnothing 220 \text{mm}$)	Bremsscheibe ($\varnothing 220 \text{mm}$)	Disco freno ($\varnothing 220 \text{mm}$)	
	11	8B00 26846	3	Cuscinetto ($\varnothing 25 \times \varnothing 47 \times 16 \text{mm}$)	Bearing ($\varnothing 25 \times \varnothing 47 \times 16 \text{mm}$)	Roulement ($\varnothing 25 \times \varnothing 47 \times 16 \text{mm}$)	Kugellager ($\varnothing 25 \times \varnothing 47 \times 16 \text{mm}$)	Cojinete ($\varnothing 25 \times \varnothing 47 \times 16 \text{mm}$)	
	12	8000 86940	2	Distanziale	Spacer	Entretoise	Distanzstück	Separador	
	13	8000 86938	1	Distanziale	Spacer	Entretoise	Distanzstück	Separador	
	14	8000 86939	1	Distanziale	Spacer	Entretoise	Distanzstück	Separador	
	15	69N4 29005	36	Nipplo	Nipple	Nipple	Nippel	Nipple	
	16	8C00 72621	1	Perno	Pin	Pivot	Bolzen	Perno	
	17	8000 64301	1	Dado	Nut	Ecrou	Mutter	Tuerca	
	18	8000 82075	1	Tampone parastrappi	Flexible coupling	Piece caoutchouc	Gummidämpfer	Para-tirones	
	19	8000 86952	1	Ass. flangia	Flange	Bride	Flansch	Brida	
R	20	8A00 85291	1	Corona (Z = 43)	Ring gear (Z = 43)	Couronne (Z = 43)	Kranz (Z = 43)	Corona (Z = 43)	
R	20	8B00 85291	1	Corona (Z = 44)	Ring gear (Z = 44)	Couronne (Z = 44)	Kranz (Z = 44)	Corona (Z = 44)	
S	20	8C00 85291	1	Corona (Z = 45)	Ring gear (Z = 45)	Couronne (Z = 45)	Kranz (Z = 45)	Corona (Z = 45)	
R	20	8D00 85291	1	Corona (Z = 46)	Ring gear (Z = 46)	Couronne (Z = 46)	Kranz (Z = 46)	Corona (Z = 46)	
R	20	8E00 85291	1	Corona (Z = 47)	Ring gear (Z = 47)	Couronne (Z = 47)	Kranz (Z = 47)	Corona (Z = 47)	
	21	8B00 40796	6	Vite	Screw	Vis	Schraube	Tornillo	
	22	8E00 79783	1	Ass. catena	Chain assy	Chaîne compl.	Kette kpl.	Cadena compl.	
				5/8"x1/4" (112maglie)	5/8"x1/4"(112 link)	5/8"x1/4"(112maillon)	5/8"x1/4"(112Schake)	5/8"x1/4"(112malla)	
A	22	8000 65442	1	Ass. catena	Chain assy	Chaîne compl.	Kette kpl.	Cadena compl.	
				5/8"x1/4" (112maglie)	5/8"x1/4"(112 link)	5/8"x1/4"(112maillon)	5/8"x1/4"(112Schake)	5/8"x1/4"(112malla)	

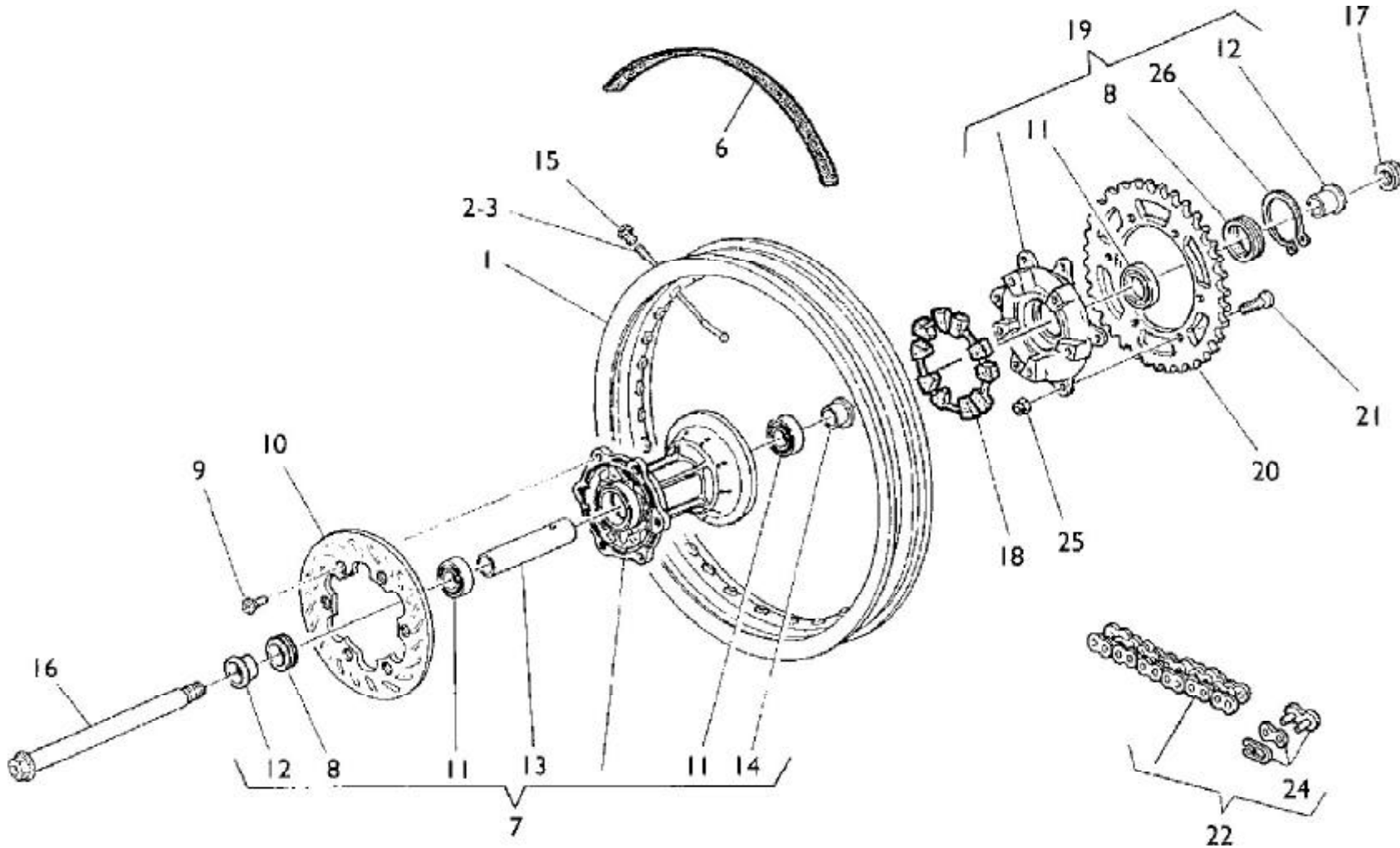

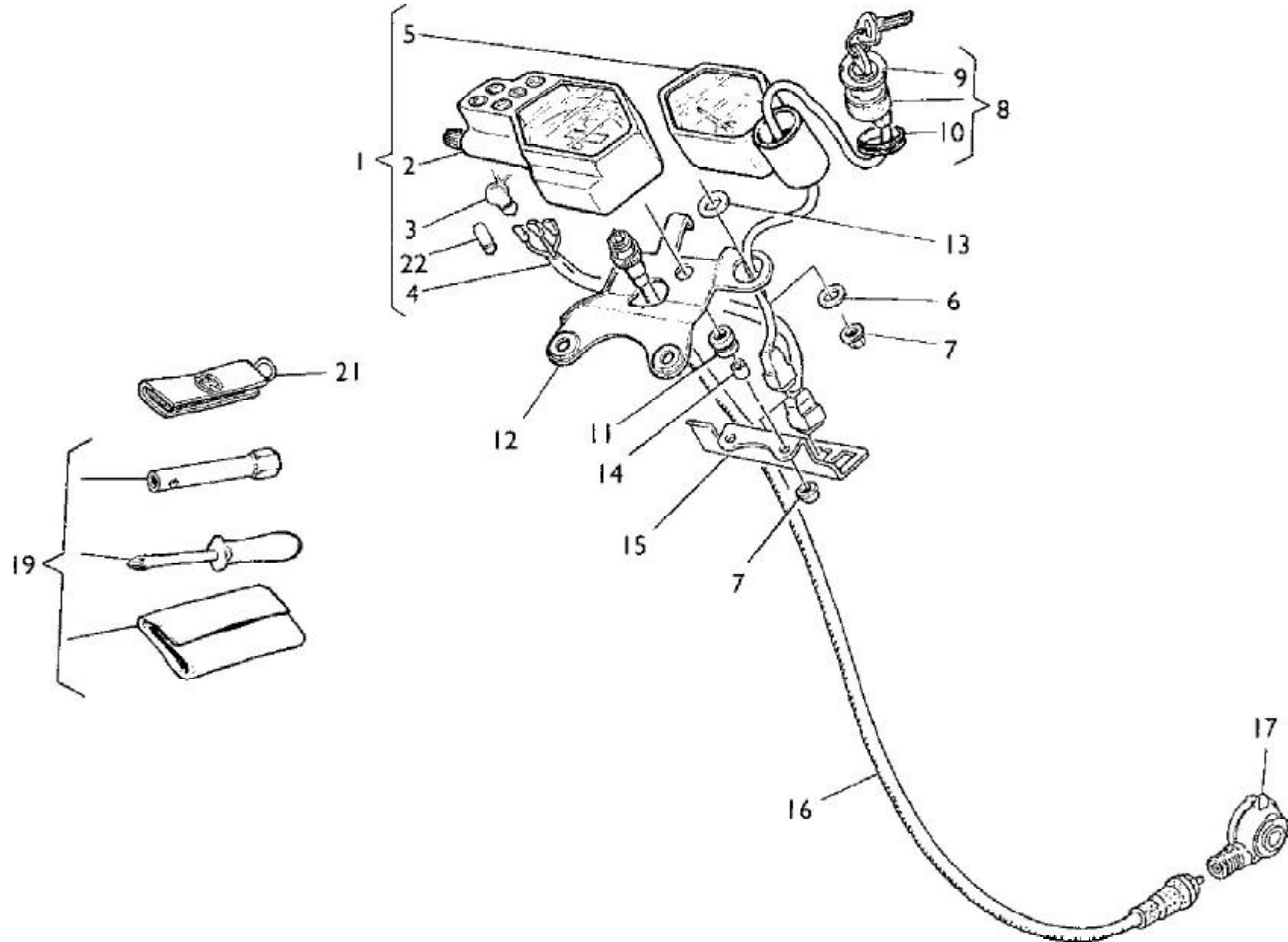

Note Notes Notas	Pos. No. Index Pos.	N. Cod. Code No. Nr. Code Code Nr N. Cod.	Q.tà Q.ty Q.te M.ge C.ad	DENOMINAZIONE	NAME	DESIGNATION	BESHREIBUNG	DENOMINACION	Validità Validity Validité Gültig Validez
	1	8000 92346	1	Ass.contakm-contamiglia/ contagiri	Speedometer (km/h-mph) / Rev. counter assy	Compteur-km/ mph,Compte- tours compl.	Tachometer (km/h-mph) / Drehzahlmesser kpl.	Cuenta km--meilla/ Cuenta-meilla compl.	
	2	8000 92345	1	Contakm-Contamiglia	Odometer (mph)	Compteur-mille	Tachometer	Cuenta-meilla	
	3	8000 20602	4	Lampadina (12V/1,2W)	Lamp (12V/1,2W)	Lampe (12V/1,2W)	Lampe (12V/1,2W)	Lamparilla (12V/1,2W)	
	4	8000 88463	1	Cablaggio	Cable	Cable	Kabel	Cable	
	5	8000 92344	1	Contagiri	Rev. counter	Compte-tours	Drehzahlmesser	Cuenta-Revoluciones	
	6	8000 22271	2	Rosetta	Washer	Rondelle	Scheibe	Arandela	
	7	8000 61313	4	Dado	Nut	Ecrou	Mutter	Tuerca	
	8	8000 74259	1	Interr. accensione completo	Ignition switch assy	Interrupteur pour allum. comp.	Schalter, Kpl.	Interruptor encendido compl.	
	9	8000 74258	1	Ghiera	Ring nut	Embout	Nutmutter	Virola	
	10	8000 50569	1	Distanziale	Spacer	Entretoise	Distanzstück	Separador	
	11	8000 62651	4	Antivibrante	Silent-block	Antivibration	Schwingungsdämpfer	Anti-vibrador	
	12	8000 87121	1	Piastra	Plate	Plaque	Platte	Placa	
	13	80B0 56359	2	Rosetta	Washer	Rondelle	Scheibe	Arandela	
	14	8000 25053	4	Distanziale	Spacer	Entretoise	Distanzstück	Separador	
	15	8000 85154	1	Piastra	Plate	Plaque	Platte	Placa	
	16	8000 71759	1	Trasmissione contachilometri	Speedometer cable	Câble compteur-km	Tachokabel	Cable cuenta-kilómetros	
SS	17	8000 88386	1	Rinvio contachilometri	Odometer transm.	Renvoi compte-km.	Vorgelege Kilometerzähler	Reenvio cuenta-kilómetros	
TT	17	8000 77827	1	Rinvio contachilometri	Odometer transm.	Renvoi compte-km.	Vorgelege Kilometerzähler	Reenvio cuenta-kilómetros	
	19	8000 87106	1	Borsa attrezzi completa	Tool bag	Trousse à outils	Werkzeugtasche	Bolsa compl.	
D	21	8000 72037	1	Porta chiavi	Key-ring	Porte-clefs	Schlüsselring	Llavero	
	22	8000 60033	4	Lampadina (12V/2W)	Lamp (12V/2W)	Lampe (12V/2W)	Lampe (12V/2W)	Lamparilla (12V/2W)	

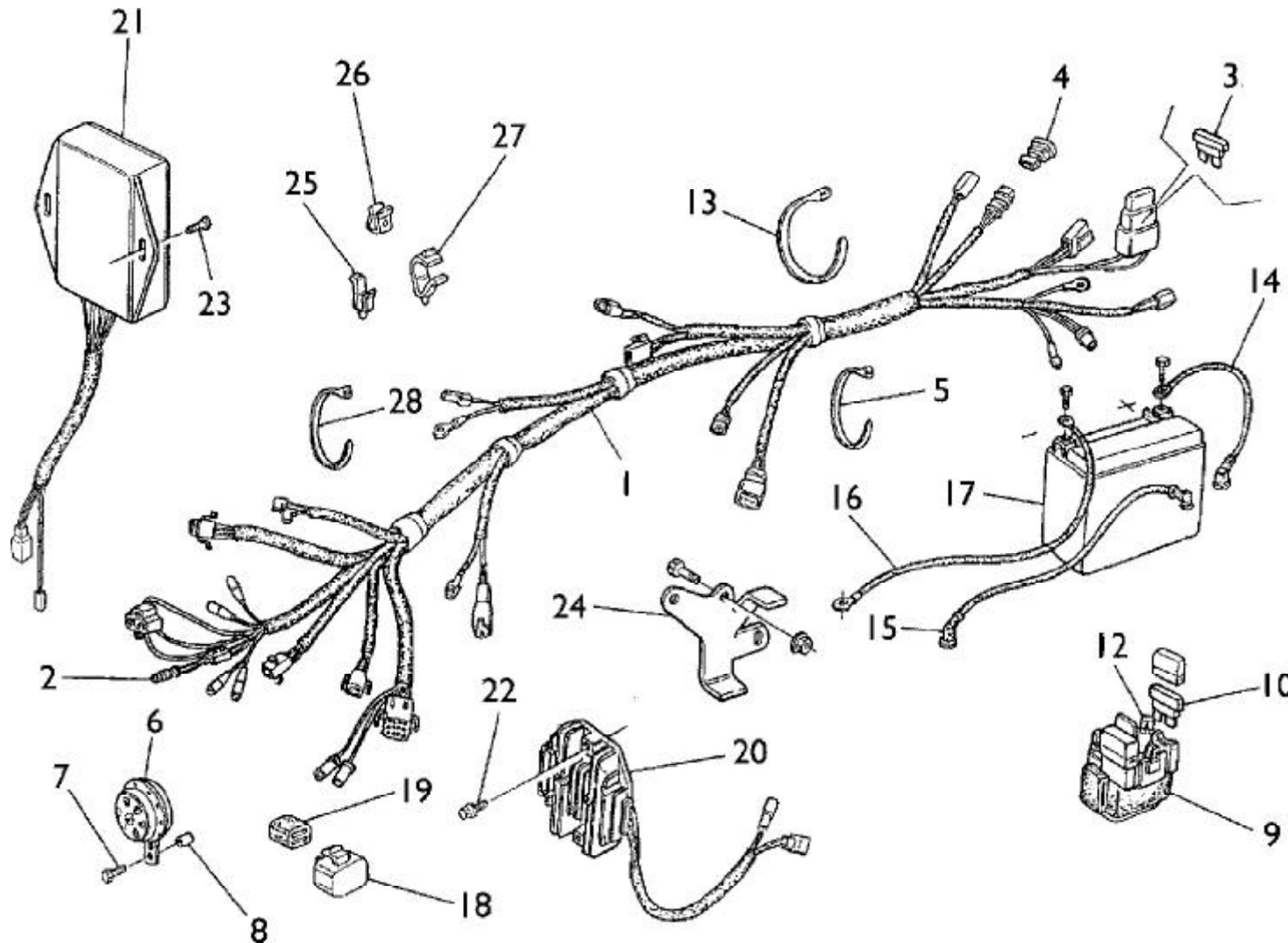

Note Notes Notas	Pos. No. Index Pos.	N. Cod. Code No. Nr. Code Code Nr N. Cod.	Q.tà Q.te M.ge C.ad	DENOMINAZIONE	NAME	DESIGNATION	BESHREIBUNG	DENOMINACION	Validità Validity Validité Gültig Validez
	1	8000 94746	1	Gruppo principale cavi	Cable assy	Cables compl.	Kabel Kpl.	Grupo principal cables	
	2	8000 36230	1	Lampada (12V-5W)	Lamp(12V-5W)	Lampe(12V-5W)	Lampe(12V-5W)	Lamparilla(12V-5W)	
	3	8000 47472	1	Fusibile (15A)	Fuse (15A)	Fusible (15A)	Sicherung (15A)	Fusible (15A)	
	4	8000 88515	1	Centralina sicurezza avviamento	Switching box	Boite interrupteurs	Anlasselektronik	Centralita consent. arranque	
	5	8000 56444	7	Fascetta (188 mm)	Clamp (188 mm)	Collier (188 mm)	Schelle (188 mm)	Banda (188 mm)	
	6	8A00 75934	1	Avvisatore acustico	Horn	Klaxon	Hupe	Avisador Acústico	
	7	8000 62727	1	Vite (M6x16mm)	Screw (M6x16mm)	Vis (M6x16mm)	Schraube (M6x16mm)	Tornillo (M6x16mm)	
	8	8000 40346	1	Distanziale	Spacer	Entretoise	Distanzstück	Separador	
	9	8000 91115	1	Teleruttore	Remote switch	Telerrupteur	Fernshalter	Telerruptor	
	10	8000 47472	2	Fusibile (15A)	Fuse (15A)	Fusible (15A)	Sicherung (15A)	Fusible (15A)	
	12	8SA0 67545	2	Vite	Screw	Vis	Schraube	Tornillo	
	13	8000 90552	1	Fascetta (200 mm)	Clamp (200 mm)	Collier (200 mm)	Schelle (200 mm)	Banda (200 mm)	
	14	8000 94748	1	Cavo Teleruttore-Batteria	Cable	Cable	Kabel	Cable	
	15	8000 95252	1	Cavo Motorino di avviamento- -teleruttore	Cable	Cable	Kabel	Cable	
	16	8000 95253	1	Cavetto di massa	Cable	Cable	Kabel	Cable	
	17	8000 77623	1	Accumulatore (12V-12Ah)	Battery (12V-12Ah)	Batterie (12V-12Ah)	Batterie (12V-12Ah)	Batería (12V-12Ah)	
	18	8000 88173	1	Intermittenza	Flash device	Intermitence	Blinkgeber	Intermitencia	
	19	8000 88259	1	Supporto elastico	Support	Support	Halterung	Soporte	
	20	8000 80005	1	Regolatore di tensione	Voltage rectifier	Régulateur de tension	Spannungsregler	Regulador de tensión	
	21	8000 91967	1	Centralina elettronica	Electronic device	Dispositif électronique	Zóndelektronik	Centralina electrónica	
	22	8000 62728	2	Vite	Screw	Vis	Schraube	Tornillo	
	23	8000 89069	2	Vite	Screw	Vis	Schraube	Tornillo	
	24	8000 85153	1	Piastrina supp. connettori	Plate	Plaque	Plättchen	Placa	
	25	8000 58207	1	Passacavo	Fairlead	Passe-câble	Kabelführung	Prensa-cable	
	26	8000 72494	1	Passacavo	Fairlead	Passe-câble	Kabelführung	Prensa-cable	
	27	8A00 60283	1	Passacavo	Fairlead	Passeccèble	Kabelführung	Prensacable	
	28	8000 71578	4	Fascetta (78 mm)	Clamp(78 mm)	Collier(78 mm)	Schelle (78 mm)	Banda(78 mm)	

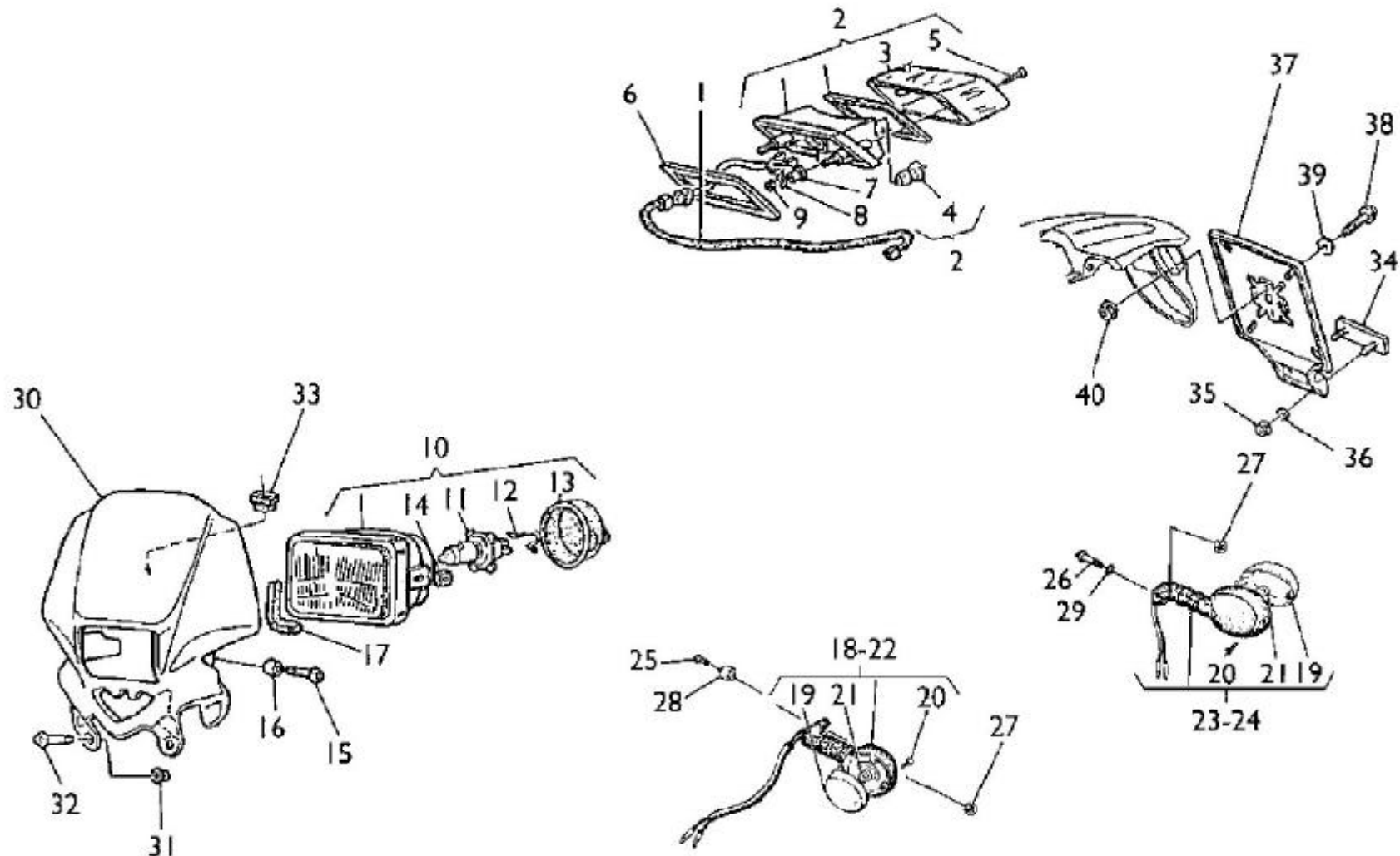

Note Notes Notas	Pos. No. Index Pos.	N. Cod. Code No. Nr. Code Code Nr N. Cod.	Q.tà Q.ty Q.te M.ge C.ad	DENOMINAZIONE	NAME	DESIGNATION	BESHREIBUNG	DENOMINACION	Validità Validity Validité Gültig Validez
	1	8000 70277	1	Gruppo cavi posteriore	Cable	Cable	Kabel	Cable	
	2	8000 65555	1	Fanale posteriore completo	Tail light	Feux arrière	Hinterleuchte	Faro trasero	
	3	8000 66480	1	Lente	Lens	Loupe	Linse	Lente	
E	4	8000 18246	1	Lampada (12V-5/21W)	Lamp (12V-5/21W)	Lampe (12V-5/21W)	Lampe (12V-5/21W)	Lamparilla (12V-5/21W)	
	4	8A00 18246	1	Lampada (12V-5/21W)	Lamp (12V-5/21W)	Lampe (12V-5/21W)	Lampe (12V-5/21W)	Lamparilla (12V-5/21W)	
	5	8000 66482	2	Vite	Screw	Vis	Schraube	Tornillo	
	6	8000 66479	1	Guarnizione	Gasket	Garniture	Dichtung	Junta	
	7	8000 62416	2	Distanziale	Spacer	Entretoise	Distanzstück	Separador	
	8	62N1 15549	2	Rosetta piana	Washer	Rondelle	Scheibe	Arandela	
	9	8000 44240	2	Dado	Nut	Ecrou	Mutter	Tuerca	
	10	8000 87562	1	Gruppo ottico completo	Optical group	Groupe optique	Optische	Grupo óptico	
	10	8000 90197	1	Gr. ottico compl.(AUS-GB-J)	Optical group (AUS-GB-J)	Groupe optique(AUS-GB-J)	Optische (AUS-GB-J)	Grupo óptico (AUS-GB-J)	
	11	8000 42946	1	Lampada (12V-55/60W)	Lamp (12V-55/60W)	Lampe (12V-55/60W)	Lampe (12V-55/60W)	Lamparilla (12V-55/60W)	
	12	8000 95648	1	Molla	Spring	Ressort	Feder	Resorte	
	13	8000 95649	1	Cuffia in gomma	Boot	Poussière	Gummihaube	Gorro de protección	
	14	8000 95650	2	Dado	Nut	Ecrou	Mutter	Tuerca	
	15	8000 62728	2	Vite	Screw	Vis	Schraube	Tornillo	
	16	8B00 69429	2	Distanziale	Spacer	Entretoise	Distanzstück	Separador	
	17	8000 88139	1	Guarnizione	Gasket	Garniture	Dichtung	Junta	
	18	8000 98241	1	Indicatore anteriore Sx.	Blinker	Clignotant	Blinker	Intermittente	
	19	8000 99583	4	Lente	Lens	Loupe	Linse	Lente	
	20	8000 73592	4	Vite	Screw	Vis	Schraube	Tornillo	
	21	8000 36726	4	Lampada (12V - 10W)	Lamp (12V - 10W)	Lampe (12V - 10W)	Lampe (12V - 10W)	Lamparilla (12V - 10W)	
	22	8000 98240	1	Indicatore anteriore Dx.	Blinker	Clignotant	Blinker	Intermittente	
	23	8000 99585	1	Indicatore posteriore Sx.	Blinker	Clignotant	Blinker	Intermittente	
	24	8000 99584	1	Indicatore posteriore Dx.	Blinker	Clignotant	Blinker	Intermittente	
	25	8000 62728	2	Vite	Screw	Vis	Schraube	Tornillo	
	26	8000 62728	2	Vite	Screw	Vis	Schraube	Tornillo	
	27	8000 44240	4	Dado	Nut	Ecrou	Mutter	Tuerca	
	29	8000 56359	2	Rosetta piana	Washer	Rondelle	Scheibe	Arandela	
	30	80D0 87060	1	Cupolino (codice colore F)	Fairing (color code F)	Carenage (code couleur F)	Verkleidung (Code Farbe F)	Cupula (còdigo colòr F)	
	30	80C0 87060	1	Cupolino (codice colore E)	Fairing (color code E)	Carenage (code couleur E)	Verkleidung (Code Farbe E)	Cupula (còdigo colòr E)	
	31	8A00 69429	2	Bussola	Bushing	Douille	Buchse	Manguito	

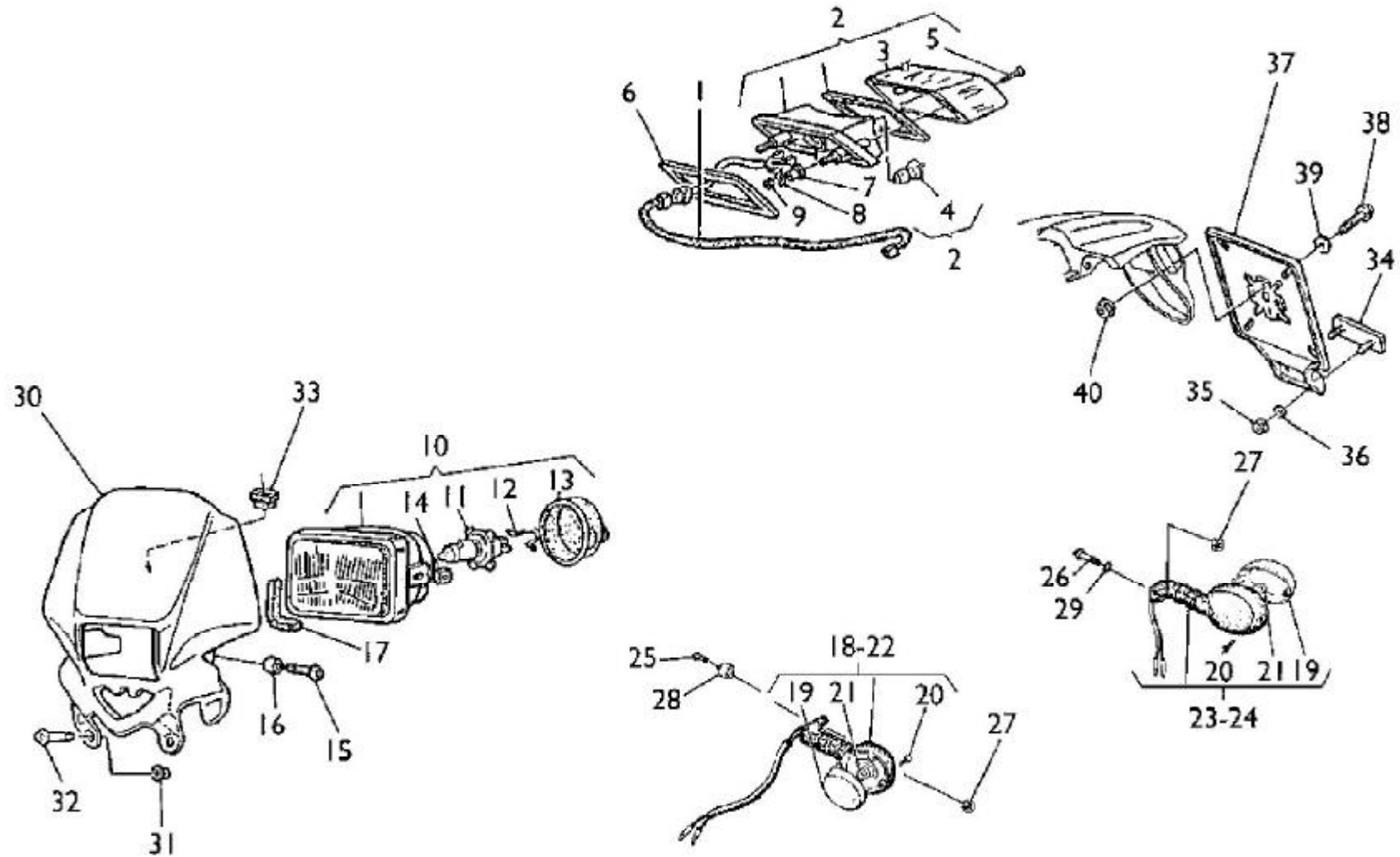



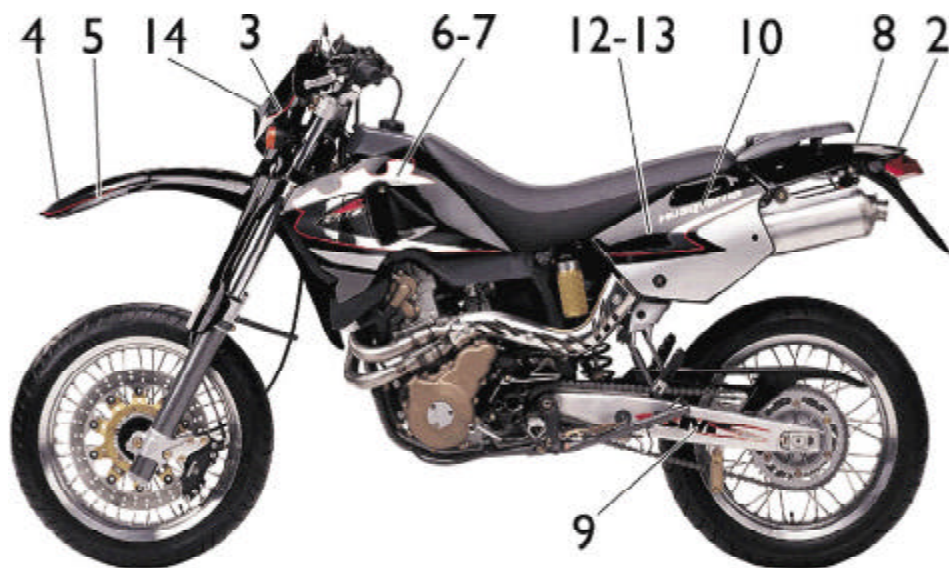

Note Notes Marke Notas	Pos. No. N. Index Pos.	N. Cod. Code No. Nr. Code Code Nr N. Cod.	Q.tà Q.ty Q.te M.ge C.ad	DENOMINAZIONE	NAME	DESIGNATION	BESHREIBUNG	DENOMINACION	Validità Validity Validité Gultig Validez
	2	80C0 89386	1	Decal "HUSQVARNA"	Transfer	Decal.	Hinterabziehbild	Adhesivo	
	3	80C0 89384	1	Decal per portafaro	Transfer	Decal.	Hinterabziehbild	Adhesivo	
	4	8000 95296	1	Logo "HUSQVARNA"	Transfer	Decal.	Hinterabziehbild	Adhesivo	
	5	80C0 89393	1	Decal per parafrangente anteriore	Transfer	Decal.	Hinterabziehbild	Adhesivo	
	6	8000 95291	1	Decal per convogliatore Sx.	L.H. Transfer	Decal.	Hinterabziehbild	Adhesivo	
	7	8000 95290	1	Decal per convogliatore Dx.	R.H. Transfer	Decal.	Hinterabziehbild	Adhesivo	
	8	8000 95761	2	Decal "CATALYTIC"	Transfer "CATALYTIC"	Decal. "CATALYTIC"	Hinterabziehbild "CATALYTIC"	Adhesivo "CATALYTIC"	
	9	80N0 94242	2	Decal per forcellone (SMS)	Fork Transfer (SMS)	Decal. (SMS)	Hinterabziehbild (SMS)	Adhesivo (SMS)	
	10	8000 95294	2	Decal "HUSQVARNA"	Transfer	Decal.	Hinterabziehbild	Adhesivo	
	12	8000 95293	1	Decal per fianchetto Sx	L.H. Transfer	Decal. G.	Hinterabziehbild L.	Adhesivo iz.	
	13	8000 95292	1	Decal per fianchetto Dx	R.H. Transfer	Decal. D.	Hinterabziehbild R.	Adhesivo der.	
	14	80A0 96775	1	Decal "HUSQVARNA"	Transfer	Decal.	Hinterabziehbild	Adhesivo	



Note Notes Marka Notas	Pos. No. N. Index Pos.	N. Cod. Code No. Nr. Code Code Nr N. Cod.	Q.tà Q.ty Q.te M.ge C.ad	DENOMINAZIONE	NAME	DESIGNATION	BESHREIBUNG	DENOMINACION	Validità Validity Validité Gultig Validez
	2	8000 94549	1	Decal per parafrangente anteriore	Transfer	Decal.	Hinterabziehbild	Adhesivo	
	3	8A00 94215	1	Decal per convogliatore Sx.	L.H. Transfer	Decal.	Hinterabziehbild	Adhesivo	
	4	8A00 94216	1	Decal per convogliatore Dx.	R.H. Transfer	Decal.	Hinterabziehbild	Adhesivo	
	5	8000 95761	2	Decal "CATALYTIC"	Transfer "CATALYTIC"	Decal. "CATALYTIC"	Hinterabziehbild "CATALYTIC"	Adhesivo "CATALYTIC"	
	6	80M0 94242	2	Decal per forcellone (TEE)	Fork Transfer (TEE)	Decal. (TEE)	Hinterabziehbild (TEE)	Adhesivo (TEE)	
	7	8000 94749	1	Decal per fianchetto Sx	L.H. Transfer	Decal. G.	Hinterabziehbild L.	Adhesivo iz.	
	8	8000 94750	1	Decal per fianchetto Dx	R.H. Transfer	Decal. D.	Hinterabziehbild R.	Adhesivo der.	

DISEGNO DRAWING DESSIN ZEICHNUNG DIBUJO	TAVOLA DRAWING TABLE BILD TABLA	INDEX NO. POS. N. INDICE	DISEGNO DRAWING DESSIN ZEICHNUNG DIBUJO	TAVOLA DRAWING TABLE BILD TABLA	INDEX NO. POS. N. INDICE	DISEGNO DRAWING DESSIN ZEICHNUNG DIBUJO	TAVOLA DRAWING TABLE BILD TABLA	INDEX NO. POS. N. INDICE	DISEGNO DRAWING DESSIN ZEICHNUNG DIBUJO	TAVOLA DRAWING TABLE BILD TABLA	INDEX NO. POS. N. INDICE	DISEGNO DRAWING DESSIN ZEICHNUNG DIBUJO	TAVOLA DRAWING TABLE BILD TABLA	INDEX NO. POS. N. INDICE	DISEGNO DRAWING DESSIN ZEICHNUNG DIBUJO	TAVOLA DRAWING TABLE BILD TABLA	INDEX NO. POS. N. INDICE
1511 31701	17	32	1615 40702	2	2	66N0 21211	9	5	8000 21480	11	41	8000 35531	15	3	8000 40597	13	53
1511 33302	17A	10	1617 95501	2	38	66N0 21217	12	32	8000 21480	20	20	8000 35728	8	25	8000 40717	28A	35
1513 07001	15	2	60N1 01220	16	61	66N0 21272	26	26	8000 21480	24	20	8000 35780	9	47	8000 40720	15	12
1513 41401	23	14	60N1 02461	12	7	66N1 21308	15	50	8000 21480	24A	20	8000 35781	9	46	8000 40720	17	44
1513 71301	4	9	60N1 02511	2	17	69N4 29004	25	7	8000 21535	9	41	8000 35854	12	12	8000 40813	22	7
1513 71401	9	11	60N1 02511	12	9	69N4 29004	25A	7	8000 22271	27	6	8000 35876	10	30	8000 41513	17	45
1513 74301	23	17	60N1 02525	5	8	69N4 29005	26	15	8000 22426	9	32	8000 36137	17	18	8000 42022	17A	9
1514 10702	23	13	60N1 02557	2	20	6BN0 21507	15	52	8000 22466	13	12	8000 36137	17	23	8000 42022	18	31
1514 13401	1	4	60N1 02866	6	25	6BN0 21509	9	49	8000 22551	20	3	8000 36230	28	2	8000 42023	17A	6
1516 21501	25	13	60N1 02927	3	22	8000 99475	11	35	8000 22613	5	48	8000 36241	5	49	8000 42244	6	22
1516 21501	25A	13	60N1 04134	22	4	8000 01199	22	9	8000 23110	6	16	8000 36467	5	42	8000 42278	2	43
1519 84701	1	6	60N1 07330	19	34	8000 01412	17A	12	8000 23979	13	13	8000 36726	28A	21	8000 42349	20	18
1610 77601	6	2	60N1 07330	19	34	8000 01688	26	6	8000 23981	13	9	8000 36848	9	29	8000 42349	22	19
1610 77701	6	32	60N1 07350	22	6	8000 02124	3	1	8000 23985	13	16	8000 36856	9	38	8000 42643	7	20
1610 77701	7	8	60N4 02489	16	72	8000 03170	4	13	8000 23990	13	33	8000 36857	9	37	8000 42676	10	10
1610 77702	6	33	60N4 02509	23	6	8000 04103	13	47	8000 25053	27	14	8000 37745	22	10	8000 42677	10	11
1610 77702	7	13	60NA 01082	10	7	8000 04104	13	48	8000 26884	11	18	8000 38211	15	33	8000 42781	17A	3
1611 70801	2	48	61N1 15062	9	44	8000 07001	21	2	8000 27073	11	10	8000 38350	9	35	8000 42946	28A	11
1611 71701	9	4	61N1 15191	24	19	8000 07719	6	36	8000 27403	21	36	8000 38520	10	22	8000 42955	13	52
1612 41501	9	12	61N1 15191	24A	19	8000 07719	7	6	8000 28327	8	10	8000 38767	17A	11	8000 43015	23	11
1612 48001	9	17	61N1 15195	2	3	8000 07719	8	18	8000 28327	10	15	8000 38956	17A	20	8000 43391	15	4
1612 48101	9	16	61N4 15192	16	70	8000 08536	2	21	8000 28798	13	25	8000 38957	17A	19	8000 43714	5	2
1612 84201	9	19	61N4 15192	16	73	8000 08536	17	10	8000 28799	13	24	8000 39521	1	12	8000 43789	6	13
1614 59002	6	23	61N4 15192	16	76	8000 12034	13	17	8000 28810	15	25	8000 39522	1	7	8000 43928	26	25
1615 03601	3	11	62N0 15672	2	31	8000 12045	13	27	8000 30319	22	14	8000 39523	1	2	8000 43947	15	26
1615 04201	3	27	62N0 15678	11	29	8000 12046	13	28	8000 31113	16	38	8000 39524	1	5	8000 44043	13	45
1615 04301	3	18	62N0 15682	11	27	8000 12048	13	30	8000 31981	21	34	8000 39651	25	12	8000 44240	15	15
1615 04501	3	21	62N1 15506	24	12	8000 12451	13	49	8000 32065	17A	2	8000 39651	25A	12	8000 44240	18	29
1615 10501	6	26	62N1 15506	24A	12	8000 13346	25A	3	8000 32388	17	13	8000 40346	28	8	8000 44240	20	17
1615 15601	3	20	62N1 15519	5	54	8000 14837	2	30	8000 32865	13	34	8000 40427	5	18	8000 44240	21	28
1615 26602	3	4	62N1 15534	12	8	8000 15659	7	15	8000 32866	13	32	8000 40580	13	26	8000 44240	21	31
1615 30301	2	37	62N1 15536	15	37	8000 17810	17	9	8000 32867	13	39	8000 40584	13	63	8000 44240	23	20
1615 31501	9	50	62N1 15547	21	32	8000 18048	21	10	8000 33109	13	7	8000 40586	13	51	8000 44240	28A	9
1615 33201	2	4	62N1 15547	28A	36	8000 18246	28A	4	8000 33211	13	41	8000 40587	13	62	8000 44240	28A	27
1615 34801	6	27	62N1 15549	28A	8	8000 18422	2	50	8000 33279	2	22	8000 40588	13	57	8000 44240	28A	40
1615 35101	2	25	62N1 15767	12	10	8000 19768	6	8	8000 33371	14	12	8000 40589	13	60	8000 45183	11	40
1615 35902	2	10	62NA 15767	10	8	8000 19789	2	14	8000 33373	15	43	8000 40590	13	61	8000 45194	2	11
1615 38201	12	2	64N1 20068	15	22	8000 19789	11	38	8000 33422	8	20	8000 40591	13	59	8000 45395	4	18
1615 38301	12	1	64N1 20068	20	9	8000 19965	2	62	8000 33491	21	33	8000 40592	13	58	8000 45490	21	11
1615 38802	9	26	65N1 21007	12	14	8000 20536	17	5	8000 34017	5	31	8000 40593	13	54	8000 45495	5	20
1615 39001	13	43	66N0 21196	12	19	8000 20536	17	22	8000 34451	6	30	8000 40594	13	55	8000 45495	5	41
1615 39301	3	24	66N0 21211	6	28	8000 20602	27	3	8000 34609	11	17	8000 40595	13	56	8000 45495	5	50

DISEGNO DRAWING DESSIN ZEICHNUNG DIBUJO	TAVOLA DRAWING TABLE BILD TABLA	INDEX NO. POS. N. INDICE	DISEGNO DRAWING DESSIN ZEICHNUNG DIBUJO	TAVOLA DRAWING TABLE BILD TABLA	INDEX NO. POS. N. INDICE	DISEGNO DRAWING DESSIN ZEICHNUNG DIBUJO	TAVOLA DRAWING TABLE BILD TABLA	INDEX NO. POS. N. INDICE	DISEGNO DRAWING DESSIN ZEICHNUNG DIBUJO	TAVOLA DRAWING TABLE BILD TABLA	INDEX NO. POS. N. INDICE	DISEGNO DRAWING DESSIN ZEICHNUNG DIBUJO	TAVOLA DRAWING TABLE BILD TABLA	INDEX NO. POS. N. INDICE	DISEGNO DRAWING DESSIN ZEICHNUNG DIBUJO	TAVOLA DRAWING TABLE BILD TABLA	INDEX NO. POS. N. INDICE
8000 45495	14	2	8000 54463	9	53	8000 60234	16	59	8000 62727	21	5	8000 63830	6	29	8000 69150	15	44
8000 45495	20	13	8000 54477	9	48	8000 60404	20	29	8000 62727	21	13	8000 63831	6	29	8000 69156	2	24
8000 45495	21	15	8000 54692	9	45	8000 60404	24A	29	8000 62727	28	7	8000 63948	21	25	8000 69282	15	56
8000 46225	10	4	8000 55101	14	11	8000 60464	6	15	8000 62727	28A	38	8000 64301	26	17	8000 69282	17	4
8000 46893	5	12	8000 55878	26	9	8000 60480	13	11	8000 62728	2	6	8000 64726	2	54	8000 69315	16	56
8000 46893	14	17	8000 55902	20	4	8000 60501	13	38	8000 62728	3	28	8000 64988	3	15	8000 69429	21	4
8000 46893	18	25	8000 55903	20	2	8000 60558	2	22	8000 62728	5	10	8000 65285	25A	5	8000 70277	28A	1
8000 47472	28	3	8000 56359	18	28	8000 60873	5	27	8000 62728	9	42	8000 65442	26	22	8000 70322	16	11
8000 47472	28	10	8000 56359	21	3	8000 61014	25A	6	8000 62728	11	13	8000 65464	26	24	8000 70324	16	5B
8000 47662	24	17	8000 56359	24	13	8000 61068	16	68	8000 62728	11	25	8000 65555	28A	2	8000 70328	16	35
8000 47662	24A	17	8000 56359	24A	13	8000 61078	20	15	8000 62728	12	30	8000 66238	22	5	8000 70379	23	15
8000 47708	2	13	8000 56359	28A	29	8000 61313	17	41	8000 62728	14	14	8000 66395	2	40	8000 70696	20	7
8000 47822	19	17	8000 56359	28A	39	8000 61313	19	20	8000 62728	15	54	8000 66479	28A	6	8000 71007	10	17
8000 47826	19	15	8000 56377	10	26	8000 61313	24	14	8000 62728	18	24	8000 66480	28A	3	8000 71008	10	18
8000 47985	13	18	8000 56377	20	8	8000 61313	24A	14	8000 62728	20	12	8000 66482	28A	5	8000 71009	10	19
8000 48138	9	40	8000 56381	22	3	8000 61313	27	7	8000 62728	21	5	8000 66525	11	19	8000 71011	10	25
8000 48564	9	54	8000 56409	21	19	8000 61314	16	62	8000 62728	28	22	8000 66767	13A	20	8000 71012	10	14
8000 48565	9	55	8000 56444	12	28	8000 61362	22	15	8000 62728	28A	15	8000 66774	19	33	8000 71020	4	11
8000 48591	12	31	8000 56444	24	15	8000 62200	6	7	8000 62728	28A	25	8000 66774	19	33	8000 71021	4	3
8000 48772	25	18	8000 56444	24A	15	8000 62209	8	6	8000 62728	28A	26	8000 66775	19	2	8000 71023	4	10
8000 48772	25A	18	8000 56444	28	5	8000 62416	28A	7	8000 62729	5	39	8000 66850	5	4	8000 71024	4	8
8000 48773	25	19	8000 56783	14	24	8000 62644	17	28	8000 62729	16	6	8000 66858	5	11	8000 71031	4	6
8000 48773	25A	19	8000 56800	15	24	8000 62651	27	11	8000 62729	19	22	8000 67355	19	24	8000 71034	4	7
8000 48856	6	20	8000 56806	14	25	8000 62655	15	53	8000 62729	21	14	8000 67440	22	8	8000 71035	4	12
8000 49004	12	11	8000 57155	20	23	8000 62675	17	27	8000 62729	24	32	8000 67449	5	15	8000 71154	6	24
8000 49016	6	21	8000 57155	24	26	8000 62676	17	26	8000 62729	24A	32	8000 67457	13	10	8000 71154	7	5
8000 49032	11	37	8000 57155	24A	26	8000 62725	2	18	8000 62729	28A	32	8000 67458	13	46	8000 71158	10	27
8000 49608	8	4	8000 58207	28	25	8000 62725	5	5	8000 62730	2	39	8000 67496	23	7	8000 71159	10	28
8000 49654	24	6	8000 58541	3	6	8000 62725	5	16	8000 62730	3	13	8000 67558	13	68	8000 71160	10	29
8000 49654	24A	6	8000 59289	17	19	8000 62725	5	28	8000 62730	8	2	8000 67610	5	30	8000 71230	9	43
8000 50322	3	26	8000 59289	17	25	8000 62725	7	9	8000 62730	8	17	8000 67703	23	21	8000 71570	26	8
8000 50454	5	53	8000 59801	5	9	8000 62725	15	36	8000 62730	21	8	8000 67824	4	16	8000 71578	28	28
8000 50455	5	33	8000 59802	5	6	8000 62725	22	13	8000 62731	3	12	8000 67970	14	4	8000 71620	17	12
8000 50569	27	10	8000 59803	5	7	8000 62726	5	19	8000 62732	15	29	8000 67997	15	38	8000 71623	17	14
8000 50808	28A	33	8000 59803	14	13	8000 62726	5	44	8000 62733	24A	24	8000 67997	17	17	8000 71624	17	7
8000 51148	9	39	8000 59839	17A	18	8000 62726	25	15	8000 62795	15	14	8000 69040	16	46	8000 71625	17	7
8000 51746	7	19	8000 59939	3	25	8000 62727	2	16	8000 62795	17	39	8000 69041	16	47	8000 71759	27	16
8000 51957	25	10	8000 59940	2	28	8000 62727	5	52	8000 62796	15	7	8000 69056	15	9	8000 71806	24	22
8000 51957	25A	10	8000 59942	2	49	8000 62727	7	23	8000 63817	2	47	8000 69056	15	46	8000 71806	24A	22
8000 53259	24A	28	8000 59977	6	14	8000 62727	12	4	8000 63821	9	22	8000 69125	20	5	8000 72037	27	21
8000 53339	2	46	8000 60033	27	22	8000 62727	14	1	8000 63822	9	2	8000 69148	21	21	8000 72168	17A	13
8000 54136	10	32	8000 60233	16	58	8000 62727	20	16	8000 63829	6	29	8000 69149	21	22	8000 72268	18	27

DISEGNO DRAWING DESSIN ZEICHNUNG DIBUJO	TAVOLA DRAWING TABLE BILD TABLA	INDEX NO. POS. N. INDICE	DISEGNO DRAWING DESSIN ZEICHNUNG DIBUJO	TAVOLA DRAWING TABLE BILD TABLA	INDEX NO. POS. N. INDICE	DISEGNO DRAWING DESSIN ZEICHNUNG DIBUJO	TAVOLA DRAWING TABLE BILD TABLA	INDEX NO. POS. N. INDICE	DISEGNO DRAWING DESSIN ZEICHNUNG DIBUJO	TAVOLA DRAWING TABLE BILD TABLA	INDEX NO. POS. N. INDICE	DISEGNO DRAWING DESSIN ZEICHNUNG DIBUJO	TAVOLA DRAWING TABLE BILD TABLA	INDEX NO. POS. N. INDICE	DISEGNO DRAWING DESSIN ZEICHNUNG DIBUJO	TAVOLA DRAWING TABLE BILD TABLA	INDEX NO. POS. N. INDICE
8000 72290	3	9	8000 75310	19	32	8000 79073	20	30	8000 81178	16	22	8000 84424	9	30	8000 85932	20	25
8000 72348	21	23	8000 75415	11	28	8000 79075	20	10	8000 81181	16	24	8000 84474	16	10	8000 85958	20	1
8000 72411	23	9	8000 75584	2	37	8000 79077	5	2	8000 81645	2	26	8000 84486	16	24	8000 85998	24A	25
8000 72425	11	16	8000 75629	11	5	8000 79077	5	2	8000 81647	2	36	8000 84501	18	32	8000 85999	24A	31
8000 72426	11	14	8000 75672	14	20	8000 79096	24A	2	8000 81648	3	17	8000 84597	12	23	8000 86004	15	6
8000 72427	11	15	8000 75673	14	19	8000 79098	24A	8	8000 81649	3	16	8000 84702	16	4	8000 86006	9	34
8000 72494	28	26	8000 75842	19	6	8000 79099	24A	4	8000 81650	2	5	8000 84704	5	21	8000 86007	9	33
8000 72874	17	33	8000 75842	19	6	8000 79100	24A	7	8000 81660	6	1	8000 84706	5	22	8000 86048	8	9
8000 72884	17	16	8000 75868	17A	4	8000 79309	9	28	8000 81660	7	1	8000 84818	11	8	8000 86051	12	17
8000 72943	9	26	8000 76002	17	34	8000 79310	9	52	8000 81663	6	10	8000 84819	11	7	8000 86074	14	26
8000 72962	7	21	8000 76003	17	38	8000 79311	9	51	8000 81663	7	16	8000 84821	11	4	8000 86104	5	46
8000 72964	6	12	8000 76069	5	40	8000 79623	16	71	8000 81673	8	23	8000 84824	4	1	8000 86243	8	19
8000 72966	6	11	8000 76283	43	43	8000 79685	9	14	8000 81674	8	26	8000 84826	4	17	8000 86245	8	13
8000 73140	15	18	8000 76338	20	11	8000 79686	9	23	8000 81675	11	21	8000 84828	12	15	8000 86246	8	21
8000 73225	26	10	8000 76687	19	27	8000 79687	9	20	8000 81676	6	17	8000 84831	12	20	8000 86258	24	37
8000 73226	25A	21	8000 76688	19	5	8000 79688	9	18	8000 81681	10	6	8000 84832	12	37	8000 86258	24A	37
8000 73287	3	10	8000 77108	2	8	8000 79689	9	1	8000 81799	2	33	8000 85017	12	33	8000 86323	15	55
8000 73341	15	20	8000 77109	2	9	8000 79690	9	6	8000 82047	6	18	8000 85018	12	34	8000 86334	13A	6
8000 73394	17A	16	8000 77413	17A	7	8000 79691	9	7	8000 82075	26	18	8000 85018	12	35	8000 86385	16	34
8000 73482	2	29	8000 77425	2	32	8000 79692	9	8	8000 82204	2	35	8000 85020	4	2	8000 86515	24	11
8000 73518	11	2	8000 77478	12	1	8000 79693	9	10	8000 82205	2	34	8000 85024	9	31	8000 86515	24A	11
8000 73592	28A	20	8000 77623	28	17	8000 79789	26	24	8000 82347	10	21	8000 85025	9	27	8000 86746	5	51
8000 73834	28A	34	8000 77744	25	9	8000 79794	20	24	8000 82384	13A	1	8000 85153	28	24	8000 86747	5	47
8000 74258	27	9	8000 77744	25A	9	8000 80005	28	20	8000 82607	13A	18	8000 85154	27	15	8000 86936	26	2
8000 74259	27	8	8000 77827	27	17	8000 80175	13A	16	8000 82948	11	3	8000 85221	17	1	8000 86937	26	3
8000 74372	17A	1	8000 77879	13	42	8000 80176	13A	10	8000 83126	10	20	8000 85312	5	37	8000 86938	26	13
8000 74716	11	20	8000 77884	25	11	8000 80177	13A	14	8000 83136	12	16	8000 85313	5	29	8000 86939	26	14
8000 74842	16	81	8000 77884	25A	11	8000 80180	13A	4	8000 83254	1	10	8000 85314	5	32	8000 86940	26	12
8000 74861	9	24	8000 78164	20	22	8000 80183	13A	7	8000 83395	16	48	8000 85374	5	36	8000 86952	26	19
8000 74862	9	13	8000 78181	14	7	8000 80184	13A	8	8000 83794	16	74	8000 85380	6	3	8000 87053	24A	21
8000 74863	9	15	8000 78688	19	3	8000 80185	13A	9	8000 83875	15	16	8000 85380	7	12	8000 87071	5	24
8000 74864	9	3	8000 78915	19	21	8000 80186	13A	3	8000 83876	15	10	8000 85381	6	4	8000 87072	5	26
8000 75043	25	20	8000 79065	24A	27	8000 80531	2	53	8000 83904	17	2	8000 85381	7	11	8000 87091	23	1
8000 75043	25A	20	8000 79066	20	26	8000 80532	2	52	8000 83987	15	30	8000 85382	7	10	8000 87092	23	4
8000 75155	19	31	8000 79066	24	33	8000 81149	2	57	8000 84261	14	18	8000 85383	6	5	8000 87105	23	8
8000 75155	19	31	8000 79066	24A	33	8000 81151	2	12	8000 84306	14	3	8000 85385	11	22	8000 87106	27	19
8000 75166	17	15	8000 79068	24	9	8000 81161	16	32	8000 84308	14	8	8000 85386	11	39	8000 87115	26	7
8000 75166	17	20	8000 79069	24	3	8000 81162	16	31	8000 84309	14	9	8000 85388	2	23	8000 87119	5	1
8000 75291	10	12	8000 79069	24A	3	8000 81163	16	30	8000 84397	12	5	8000 85390	9	36	8000 87119	5	1
8000 75293	11	30	8000 79070	24	23	8000 81164	16	29	8000 84404	13A	12	8000 85391	7	22	8000 87120	5	3
8000 75302	10	1	8000 79070	24A	23	8000 81164	16	40	8000 84411	12	29	8000 85395	10	23	8000 87120	5	3
8000 75310	19	32	8000 79072	20	27	8000 81168	16	3	8000 84414	14	5	8000 85930	16	33	8000 87121	27	12

DISEGNO DRAWING DESSIN ZEICHNUNG DIBUJO	TAVOLA DRAWING TABLE BILD TABLA	INDEX NO. POS. N. INDICE	DISEGNO DRAWING DESSIN ZEICHNUNG DIBUJO	TAVOLA DRAWING TABLE BILD TABLA	INDEX NO. POS. N. INDICE	DISEGNO DRAWING DESSIN ZEICHNUNG DIBUJO	TAVOLA DRAWING TABLE BILD TABLA	INDEX NO. POS. N. INDICE	DISEGNO DRAWING DESSIN ZEICHNUNG DIBUJO	TAVOLA DRAWING TABLE BILD TABLA	INDEX NO. POS. N. INDICE	DISEGNO DRAWING DESSIN ZEICHNUNG DIBUJO	TAVOLA DRAWING TABLE BILD TABLA	INDEX NO. POS. N. INDICE	DISEGNO DRAWING DESSIN ZEICHNUNG DIBUJO	TAVOLA DRAWING TABLE BILD TABLA	INDEX NO. POS. N. INDICE
8000 87127	5	45	8000 89011	12	25	8000 90197	28A	10	8000 94242	29	6	8000 95649	28A	13	8000 99183	19	6
8000 87139	2	23	8000 89012	12	22	8000 90228	21	35	8000 94549	29	2	8000 95650	28A	14	8000 99475	5	35
8000 87200	15	19	8000 89069	28	23	8000 90231	13	8	8000 94549	29B	2	8000 95695	13	1	8000 99475	11	36
8000 87201	15	27	8000 89085	18	7	8000 90339	2	61	8000 94595	28A	37	8000 95761	29	5	8000 99580	19	1
8000 87202	15	28	8000 89086	18	8	8000 90506	2	60	8000 94601	16	50	8000 95761	29A	8	8000 99581	19	4
8000 87276	19	16	8000 89096	18	15	8000 90552	28	13	8000 94602	16	51	8000 95761	29B	5	8000 99583	28A	19
8000 87562	28A	10	8000 89097	18	16	8000 90584	19	7	8000 94604	16	53	8000 95887	18	2	8000 99584	28A	24
8000 87580	15	23	8000 89098	18	17	8000 90611	1	9	8000 94605	18	1	8000 95888	18	3	8000 99585	28A	23
8000 87844	15	39	8000 89099	18	18	8000 90662	1	3	8000 94609	24	18	8000 95889	18	5	8000 99675	13A	19
8000 87845	15	48	8000 89119	19	11	8000 90664	16	78	8000 94609	24A	18	8000 95891	18	10	8000 A0371	9	31
8000 87859	5	14	8000 89119	19	11	8000 90665	16	79	8000 94614	24	36	8000 95892	18	12	8000 A0372	9	27
8000 87968	16	67	8000 89124	19	12	8000 90666	16	77	8000 94614	24A	36	8000 95893	18	13	8000 A0872	5	25
8000 87994	21	29	8000 89232	16	1	8000 90670	16	8	8000 94621	13	22	8000 95894	18	20	8000 A0930	24A	38
8000 87995	21	30	8000 89233	16	2	8000 90674	1	11	8000 94623	13	69	8000 96604	4	4	8000 A1135	21	6
8000 87996	21	16	8000 89234	16	5	8000 90698	14	23	8000 94624	25A	4	8000 96747	11	26	8000 A1136	21	7
8000 88027	20	14	8000 89235	16	5A	8000 90806	12	27	8000 94705	26	1	8000 96796	3	14	8000 A1169	1	15
8000 88070	21	26	8000 89238	16	14	8000 90875	1	13	8000 94709	25	4	8000 97598	16	37	8000 A1364	2	55
8000 88071	21	24	8000 89241	16	17	8000 91115	28	9	8000 94710	26	1	8000 97599	16	16	8000 A1366	8	7
8000 88073	4	14	8000 89242	16	18A	8000 91260	2	56	8000 94746	28	1	8000 97600	16	12	8000 A1367	8	22
8000 88139	28A	17	8000 89243	16	19	8000 91479	16	9	8000 94748	28	14	8000 97601	16	13	8000 A1368	8	14
8000 88159	10	3	8000 89245	16	18	8000 91491	16	18	8000 94749	29	7	8000 97602	16	7	8000 A1369	8	12
8000 88167	2	7	8000 89245	16	21	8000 91491	16	24	8000 94749	29B	7	8000 97603	16	16	8000 A1373	2	55
8000 88173	28	18	8000 89245	16	24	8000 91492	16	18	8000 94750	29	8	8000 97603	16	37	8000 A1374	8	5
8000 88240	22	16	8000 89246	16	21	8000 91493	16	20	8000 94750	29B	8	8000 97604	16	15	8000 A3987	23	12
8000 88259	28	19	8000 89247	16	21	8000 91853	18	4	8000 94849	20	21	8000 97605	16	7	8000 A4260	1	14
8000 88386	27	17	8000 89247	16	24	8000 91856	18	11	8000 95248	19	30	8000 97606	16	28	8000 A4261	1	16
8000 88463	27	4	8000 89248	16	21	8000 91859	18	14	8000 95248	24	5	8000 97608	16	36	80A0 40596	13	50
8000 88515	28	4	8000 89249	16	23	8000 91860	18	19	8000 95248	24A	5	8000 97609	16	43	80A0 66222	2	15
8000 88536	12	6	8000 89250	16	25	8000 91967	28	21	8000 95249	19	25	8000 97610	16	42	80A0 66800	5	3
8000 88597	19	10	8000 89251	16	26	8000 92057	8	1	8000 95252	28	15	8000 97611	16	45	80A0 67186	5	1
8000 88626	11	33	8000 89252	16	27	8000 92156	21	7	8000 95253	28	16	8000 97612	16	44	80A0 69551	18	22
8000 88627	11	31	8000 89254	16	28A	8000 92158	21	6	8000 95269	13	36	8000 97613	16	41	80A0 73456	17	3
8000 88628	11	32	8000 89261	16	39	8000 92224	21	37	8000 95290	29A	7	8000 97935	9	28	80A0 74388	17	11
8000 88770	25	21	8000 89266	16	52	8000 92239	12	18	8000 95291	29A	6	8000 97972	2	1	80A0 75630	11	9
8000 88771	24	25	8000 89518	16	8	8000 92240	12	36	8000 95292	29A	13	8000 98006	4	2	80A0 78988	11	23
8000 88772	24	30	8000 89644	23	10	8000 92344	27	5	8000 95293	29A	12	8000 98007	4	1	80A0 79068	24A	9
8000 88773	24	31	8000 89743	1	1	8000 92345	27	2	8000 95294	29A	10	8000 98240	28A	22	80A0 79083	18	6
8000 88774	24	29	8000 89813	19	23	8000 92346	27	1	8000 95296	29A	4	8000 98241	28A	18	80A0 83767	16	66
8000 88775	24	28	8000 89814	19	19	8000 93872	16	18	8000 95452	14	3	8000 98243	22	17	80A0 83768	16	65
8000 88776	24	27	8000 89815	19	14	8000 93923	3	3	8000 95452	14	3	8000 98541	2	1	80A0 84820	8	11
8000 88777	24	38	8000 90104	24	34	8000 93924	3	8	8000 95454	14	15	8000 98922	13A	17	80A0 86523	24	10
8000 88782	24	35	8000 90104	24A	34	8000 94098	22	2	8000 95648	28A	12	8000 98988	13A	5	80A0 86523	24A	10

DISEGNO DRAWING DESSIN ZEICHNUNG DIBUJO	TAVOLA DRAWING TABLE BILD TABLA	INDEX NO. POS. N. INDICE	DISEGNO DRAWING DESSIN ZEICHNUNG DIBUJO	TAVOLA DRAWING TABLE BILD TABLA	INDEX NO. POS. N. INDICE	DISEGNO DRAWING DESSIN ZEICHNUNG DIBUJO	TAVOLA DRAWING TABLE BILD TABLA	INDEX NO. POS. N. INDICE	DISEGNO DRAWING DESSIN ZEICHNUNG DIBUJO	TAVOLA DRAWING TABLE BILD TABLA	INDEX NO. POS. N. INDICE	DISEGNO DRAWING DESSIN ZEICHNUNG DIBUJO	TAVOLA DRAWING TABLE BILD TABLA	INDEX NO. POS. N. INDICE	DISEGNO DRAWING DESSIN ZEICHNUNG DIBUJO	TAVOLA DRAWING TABLE BILD TABLA	INDEX NO. POS. N. INDICE
80A0 87427	14	16	8A00 42700	10	9	8A00 75672	14	20	8A00 90583	19	25	8B00 67545	23	18	8D00 60523	13	73
80A0 96775	29A	14	8A00 47773	11	12	8A00 75934	28	6	8A00 92301	19	9	8B00 67997	16	75	8D00 67545	23	19
80B0 43928	15	11	8A00 49617	12	3	8A00 75984	5	34	8A00 94215	29	3	8B00 68934	19	28	8D00 85017	12	33
80B0 43928	15	13	8A00 50322	3	26	8A00 76024	24	1	8A00 94215	29B	3	8B00 69056	15	31	8D00 85291	26	20
80B0 43928	15	17	8A00 53155	16	60	8A00 78647	12	13	8A00 94216	29	4	8B00 69285	17A	21	8DA0 87179	17	30
80B0 43928	15	41	8A00 55241	20	6	8A00 78681	19	11	8A00 94216	29B	4	8B00 69429	28A	16	8E00 67545	8	8
80B0 56359	27	13	8A00 55241	25A	15	8A00 78765	2	51	8A00 94601	16	50	8B00 70379	23	16	8E00 67545	17	36
80B0 69056	15	31	8A00 59975	7	18	8A00 79058	3	19	8A00 94602	16	51	8B00 72966	7	14	8E00 79783	26	22
80B0 75766	2	42	8A00 60283	28	27	8A00 79067	24	2	8A00 94604	16	53	8B00 73458	15	5	8E00 85017	12	33
80C0 05761	13	5	8A00 60415	2	45	8A00 79685	9	14	8A00 94616	15	1	8B00 77740	24A	1	8E00 85291	26	20
80C0 87060	28A	30	8A00 60463	9	9	8A00 80171	13A	11	8A00 97739	10	24	8B00 80661	2	27	8E00 99475	14	22
80C0 89384	29A	3	8A00 60522	13	70	8A00 80173	13A	13	8A00 97973	4	5	8B00 80668	2	59	8F00 09408	12	21
80C0 89386	29A	2	8A00 60523	13	72	8A00 80174	13A	15	8A00 97976	17	29	8B00 80669	2	58	8F00 10789	3	7
80C0 89393	29A	5	8A00 62129	25	17	8A00 80661	2	27	8A00 99183	19	6A	8B00 82879	25	3	8F00 85017	12	33
80D0 87059	21	1	8A00 62129	25A	17	8A00 80668	2	59	8A00 99475	11	34	8B00 82879	26	6	8F00 99475	14	21
80D0 87060	28A	30	8A00 62797	17A	14	8A00 80669	2	58	8AA0 36237	17A	8	8B00 85017	12	33	8G00 70208	21	9
80D0 87061	5	17	8A00 62797	18	30	8A00 82948	11	1	8AA0 76028	17	24	8B00 85291	26	20	8G00 84311	22	18
80D0 87062	5	43	8A00 63644	2	44	8A00 83332	13A	2	8AA0 85926	15	40	8B00 99475	5	13	8G00 85017	12	33
80E0 83767	16	66	8A00 65503	16	55	8A00 83999	15	42	8AA0 85927	15	47	8B00 99475	5	38	8H00 36022	9	21
80E0 83768	16	65	8A00 65847	6	31	8A00 84470	12	26	8AB0 66630	22	1	8BA0 89851	21	20	8H00 70208	21	9
80F0 87059	21	1	8A00 66525	6	9	8A00 84473	12	24	8AB0 76028	17	24	8BC0 89851	21	20	8H00 85017	12	33
80G0 87061	5	17	8A00 66525	7	17	8A00 85017	12	33	8AP0 12041	13	4	8C00 16930	9	25	8L00 73458	15	45
80G0 87062	5	43	8A00 66661	17	40	8A00 85291	26	20	8B00 26846	26	11	8C00 24058	13	3	8L00 84311	22	18
80H0 70209	21	12	8A00 66850	5	4	8A00 85312	5	37	8B00 35876	10	31	8C00 50322	3	26	8L00 84311	22	18
80L0 12032	13	6	8A00 66850	5	4	8A00 85312	5	37	8B00 38752	22	12	8C00 52306	1	8	8M00 73458	15	8
80L0 70209	21	12	8A00 66953	7	7	8A00 85378	3	2	8B00 40796	26	21	8C00 61121	17	8	8NA0 05761	13	5
80M0 94242	29B	6	8A00 67545	18	26	8A00 85926	15	40	8B00 42029	17	6	8C00 62797	24	24	8Q00 27910	13	2
80N0 94242	29A	9	8A00 67823	4	15	8A00 85926	15	40	8B00 42029	17A	17	8C00 67545	6	35	8SA0 67545	28	12
8A00 01815	15	21	8A00 67997	6	6	8A00 85927	15	47	8B00 47773	11	6	8C00 67545	8	16			
8A00 02124	3	5	8A00 69056	16	49	8A00 85927	15	47	8B00 50322	3	26	8C00 67963	5	23			
8A00 15960	2	19	8A00 69056	24A	24	8A00 85928	15	32	8B00 53546	15	51	8C00 67997	10	16			
8A00 15960	2	41	8A00 69138	17A	15	8A00 85929	15	49	8B00 54139	10	2	8C00 67997	16	69			
8A00 15960	3	23	8A00 69282	17	42	8A00 86498	16	63	8B00 55532	6	19	8C00 67997	17	21			
8A00 18246	28A	4	8A00 69429	18	23	8A00 86499	16	57	8B00 57760	20	19	8C00 68934	19	29			
8A00 20182	17	31	8A00 69429	28A	31	8A00 87053	24	21	8B00 60522	13	71	8C00 69056	16	64			
8A00 23108	11	11	8A00 74181	24A	30	8A00 87054	19	13	8B00 61095	9	39	8C00 70034	16	80			
8A00 24058	13	3	8A00 74718	25	14	8A00 88230	10	13	8B00 65572	25	16	8C00 72621	26	16			
8A00 28553	11	24	8A00 74718	25A	14	8A00 88671	25	6	8B00 65572	25A	16	8C00 85017	12	33			
8A00 30342	14	10	8A00 74861	9	24	8A00 88672	25	5	8B00 67207	21	17	8C00 85291	26	20			
8A00 31503	10	5	8A00 75042	25	8	8A00 88746	19	18	8B00 67545	6	34	8CA0 50798	24	16			
8A00 36984	17	35	8A00 75042	25A	8	8A00 88780	26	2	8B00 67545	8	15	8CA0 50798	24A	16			
8A00 37140	14	6	8A00 75153	17A	5	8A00 88781	26	3	8B00 67545	8	24	8CA0 87179	17	30			

CATALOGO PARTI DI RICAMBIO - PARTS CATALOG
CATALOGUE PIECES DE RECHANGE - ERSATZTEILKATALOG
CATALOGO PIEZAS DE REPUESTO



SMS 610



TEE 610 dual purpose

TEE 610 Dual Purpose / 2004
SMS 610 / 2004

Part. N° 8000 A4261